



Telecommunications
Standards Advisory
Committee (TSAC)

Next Generation
National Broadband
Network (NGNBN)

Coaxial Home
Networking

IDA RS CCHN
Issue 1, Jul 2011

Infocomm Development Authority of Singapore
Resource Management & Standards
10 Pasir Panjang Road
#10-01 Mapletree Business City
Singapore 117438

© Copyright of IDA, 2011

This document may be downloaded from the IDA website at <http://www.ida.gov.sg>
and shall not be distributed without written permission from IDA

Acknowledgement

The Info-communications Development Authority of Singapore (IDA) and the Telecommunications Standards Advisory Committee (TSAC) like to acknowledge the following members of the Technical Committee Working Group 2 (TSTC WG2) for their invaluable contributions to the preparation of this Reference Specification:

TSTC WG2 Chairman: Mr Heng Kwee Tong, SingTel
Co-Chairman: Mr Tan Boon Huat, StarHub

S/N	Organisation	Name
1	2Wire Asia	Mr Barry Chen Sales Director
2	A*STAR Institute for Infocomm Research	Dr. Francois Chin Po Shin Programme Manager
3		Mr Tony Quek Quee Seng Research Engineer
4	Advanced Digital Broadcast	Mr Douglas Pierce VP & GM APAC Business Unit
5	Alcatel-Lucent Singapore	Mr Philippe GERARD CTO, Singapore & Brunei
6		Mr Kho Sian Teck Solution Architect - Next Generation Networks
7	Association of Telecommunications Industry of Singapore	Mr Khoo Teng Lock
8	Aztech Technologies Pte Ltd	Mr Ong Ann Tiong Snr R&D Manager
9	BICSI Southeast Asia	Mr Khoo Lick Chye Managing Director Wireless-Home-Office Pte Ltd
10	Convergent Systems (S) Pte Ltd	Mr Michael Tan Director
11		Mr Jason Teo Channel Sales Manager
12	Huawei International Pte Ltd	Mr Eason Chua Joo Seng Product Manager
13	IDA	Ms Veronica Tan NGNBN Team
14		Mr Andy Ho Emerging Communications
15	Lantiq Asia Pacific Pte Ltd	Mr Volkening Ingo
16	Marvell Asia Pte Ltd	Mr Leung Hon Kit Field Application Manager
17	Microsoft Singapore Pte Ltd	Mr Chew Tat Leong National Technology Officer
18	M1 Limited	Mr Bernard Chin Assist General Manager
19	Nanyang Technological University	Assoc Prof So Ping Lam School of Electrical & Electronic Engineering
20	Nucleus Connect Pte Ltd	Mr. Tran Tan Phat Senior Engineer
21	OpenNet Pte Ltd	Mr Melvin Chan Project Manager
22	Panasonic Singapore Laboratories Pte Ltd	Mr Chien Koh Wei Team Leader
23		Mr Yu Zhan Raymond Senior Staff Engineer

24	Qualcomm Atheros	Mark Foo Regional Sales Manager
25	Sigma Designs Technology Singapore Pte Ltd	Mr Ron Lee
26	Singapore Telecommunications Ltd	Mr Yong Hai Hung Engineer (Network Technology Development)
27	StarHub Ltd	Mr Foo Ming Jap Senior Manager
28		Ms Ho Meow Wai Manager
29	Technicolor Asia Pacific Holdings Pte Ltd	Mr Dala Singh Sales, ASEAN
30		Mr Colin Teoh Chew Hin Sales, ASEAN
31	V One Multimedia Pte Ltd	Mr Tan Thye Seng CEO

TSAC is responsible for the strategic direction, work programmes and procedures for standards-setting, and acts as the advisory body to IDA in meeting the needs of all stakeholders.

TSAC is supported by a Technical Committee (TSTC) where professional, trade and consumers' interest in information and communications is represented by a wide sector of the info-communications industry, comprising network operators, equipment suppliers and manufacturers, academia and researchers, professional bodies and other government agencies.

TSAC Membership

TSAC Chairman:

Mr Raymond Lee Director (Resource Management & Standards), Infocomm Development Authority of Singapore

TSAC Members:

Mr Lim Yuk Min Deputy Director (Resource Management and Standards), Infocomm Development Authority of Singapore
(TSAC Vice-Chairman)

Assoc Prof Tham Chen Khong Department Head, Agency for Science, Technology and Research

Mr Darwin Ho Kang Min Association of Telecommunications Industry of Singapore

Mr Lim Chin Siang Director (IT & Technology), Media Development Authority

Mr Patrick Scodeller Chief Technical Officer, M1 Ltd

Assoc Prof Li Kwok Hung Nanyang Technological University, School of Electrical & Electronic Engineering

Prof Ko Chi Chung National University of Singapore, Department of Electrical & Computer Engineering

Assoc Prof Tham Chen Khong National University of Singapore, Department of Electrical & Computer Engineering

Mr Simon Smith Senior Manager Regulatory, Pacnet Internet (S) Ltd

Mr Edwin Lok Manager (Engineering) , Pacnet Internet (S) Ltd

Mr Lee Siak Kwee Director (Mobile Network Access), Singapore Telecommunications Ltd

Mr Tan Seow Nguan Director (Network System Engineering), Singapore Telecommunications Ltd

Mr Lim Cheow Hai Director (Access Engineering), Singapore Telecommunications Ltd

Mr Soh Keng Hock Director (Private IP Engineering & VAS), Singapore Telecommunications Ltd

Mrs Leong Suet Mui Principle Technical Executive (Standards Division), Spring Singapore

Mr Peter Cook Vice President (Network Mobile Technology & Planning Group), StarHub Ltd

Mr Mah Chin Paw The Institution of Engineers, Singapore, AGM (Guthrie Engineering (S) Pte Ltd

Mr Leong Mun Yuen CTO and Director (Technology & Planning Group), Infocomm Development Authority of Singapore

Ms Woo Yim Leng Senior Manager (Resource Management & Standards), Infocomm Development Authority of Singapore

Contents

Part A	Introduction	1
1	Scope	1
2	General Requirements	1
2.1	Power Supply	1
2.2	Identification of Equipment	1
3	Safety Requirements	1
4	Electromagnetic Compatibility (EMC) Requirements	2
5	References	2
6	Abbreviations	3
Part B	Home Networking Transceivers (based on ITU-T Rec. G.9954 01/2007)	4
1	System Reference Model For Coaxial Home Networking Transceivers	4
2	Frequency And Power Spectral Density	6
2.1	Frequency Spectrum	6
2.2	Isolation Filter Requirements	7
2.3	Spectral Masks	8
3	Electrical Characteristics	8
3.1	Transmitter Power	8
3.2	Transmit Voltage	8
4	RF Pass-through Port (Optional)	8

This Reference Specification is a living document which is subject to review and revision.

Reference Specifications and Guides are informative documents and are not used for approval of customer equipment. They are either one of the following types of documents:

Informative and interim documents on customer equipment standards which are yet to be adopted by network operators; or

Informative documents describing network standards adopted by the public telecommunication networks in Singapore.

NOTICE

THE INFOCOMM DEVELOPMENT AUTHORITY OF SINGAPORE MAKES NO WARRANTY OF ANY KIND WITH REGARD TO THIS MATERIAL AND SHALL NOT BE LIABLE FOR ERRORS CONTAINED HEREIN OR FOR INCIDENTAL OR CONSEQUENTIAL DAMAGES IN CONNECTION WITH THE USE OF THIS MATERIAL.

PART A INTRODUCTION

1 SCOPE

- 1.1 This specification describes the use of in-premises coaxial wiring for high speed data networking within the home. The Specification defines the minimum technical requirements for the connection of Home Networking Transceivers (HNT) over the in-premises coaxial wiring.
- 1.2 The use of the coaxial home networking **MUST NOT** interfere with the licensed TV or broadband access services carried in the same medium.
- 1.3 Compliance with this Specification on the whole is voluntary. However, HNT users and providers can only claim that their devices are in conformity with this Specification when mandatory provisions indicated by the words “shall” and “must” are fulfilled.

2 GENERAL REQUIREMENTS

2.1 Power Supply

The HNT may be a.c. or d.c. powered. For an a.c. powered equipment, the Specification shall be complied with when operating from an a.c. mains supply of voltage, $230V \pm 10\%$ and frequency, $50 \text{ Hz} \pm 2\%$. Where external power supply is used, e.g. AC adaptor, it shall not affect the capability of the equipment to meet the Specification.

2.2 Identification of Equipment

The HNT equipment shall be marked with the supplier or manufacturer’s name or identification mark, and the supplier or manufacturer’s model or type reference. The marking required shall be legible, indelible and readily visible.

3 SAFETY REQUIREMENTS

The HNT equipment shall be tested for compliance with the International Electrotechnical Commission IEC 60950 safety standard¹. The requirements in IEC 60950 that are applicable to the equipment (e.g. class of equipment, type of TNV circuit and types of components) shall be identified and complied with.

¹ The safety standard includes, among others, protection of telecommunications network service personnel and users of other equipment connected to the network from hazards in the HNT.

4 ELECTROMAGNETIC COMPATIBILITY (EMC) REQUIREMENTS

The HNT equipment shall comply with the EMC requirements defined in CISPR 22.

5 REFERENCES

- | | |
|-------------------------------|--|
| COPIF 2008
(09/2008) | Code of Practice for Info-communications Facilities in Buildings |
| ITU-T Rec G.9954
(01/2007) | Home Networking Transceivers – Enhanced Physical, Media Access, and Link Layer Specifications |
| IEC CISPR 22 | Information Technology Equipment - Radio disturbance characteristics – Limits and methods of measurement |
| IEC 60950:2005 | International Electrotechnical Commission – Safety of Information Technology Equipment |

6 ABBREVIATIONS

DOCSIS	Data over Cable Services Interface Specifications
HNT	Home Networking Transceivers
IF	Isolation Function
IFG	Inter-Frame Gap
LLC	Link Layer Control
MAC	Media Access Control
MII	Media Independent Interface
PSD	Power Spectral Density
RG	Residential Gateway
WAN	Wide Area Network

PART B HOME NETWORKING TRANSCEIVERS (based on ITU-T Rec. G.9954 01/2007)

1 SYSTEM REFERENCE MODEL FOR COAXIAL HOME NETWORKING TRANSCEIVERS

1.1 Figure 1-1 shows the basic reference model for in-premises coaxial home networking transceivers (HNT). The interface of concern in this Specification is the wire-side electrical and logical interface (W1) between a HNT station and the coaxial cable.

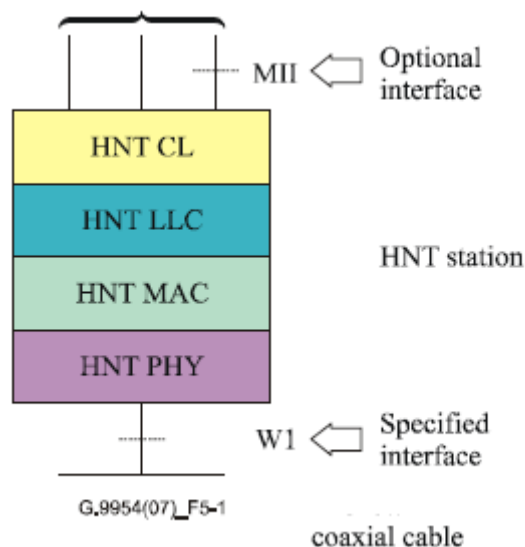

Figure 1-1 (Figure 5-1/G.9954): **Basic Reference Model**

1.2 The HNT system implements a *shared medium* single-segment network, as shown in Figure 1-2 (Figure 5-3/G.9954) below. All stations on a segment are logically connected to the same shared channel on the coaxial cable.

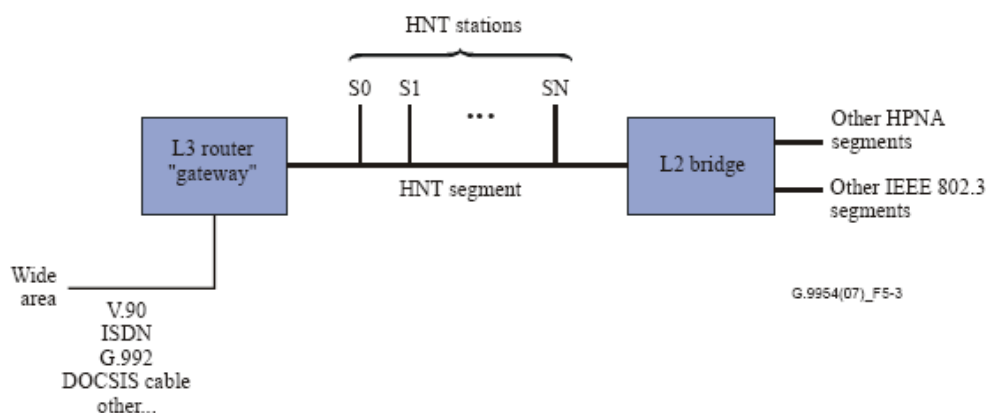

Figure 1-2 (figure 5-3/G.9954): **HNT shared medium network segment on the coaxial cable**

- 1.3 Figure 1-3 below shows an example of the home network using Coaxial Home Networking, where a variety of types of network devices (e.g. IP Set-top Boxes) are connected via the coaxial cables in the home, to a Internet Gateway Device (RG) and possible bridges to other home network segments, possibly based on other home networking technologies (e.g. wireless, power-line).

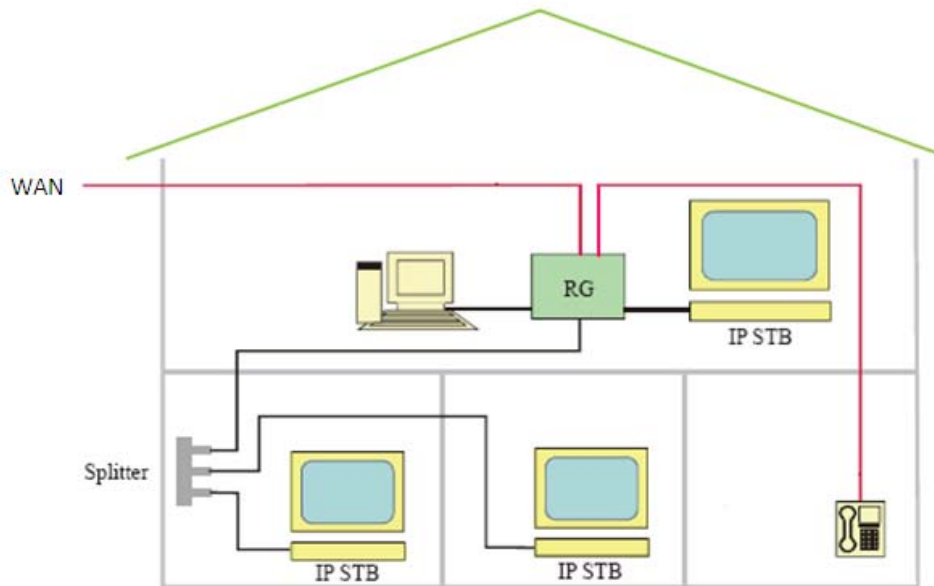

Figure 1-3 (modified from Figure 5-4/G.9954): **Home network using the coaxial cable**

- 1.4 An Isolation Function (IF) shall be implemented, where the in-premise coaxial network is not physically disconnected from the coaxial access network, to prevent interference between HNT devices operating on in-premises wiring with the licensed TV or broadband access services carried in the same medium.
- 1.5 The IF shall be installed at the distribution point, i.e. before the coaxial splitter point where the main cable is split into the different room points.
- 1.6 The IF serves two functions: to ensure network separation between neighbours and to isolate the coaxial home networking from the coaxial broadband access network.
- 1.7 The IF shall provide a minimum of 40dB isolation and shall allow the licensed TV or broadcast access services carried in the same medium to pass through to the home network and isolate the Sub-Mode F frequency spectrum from 52 - 68 MHz.

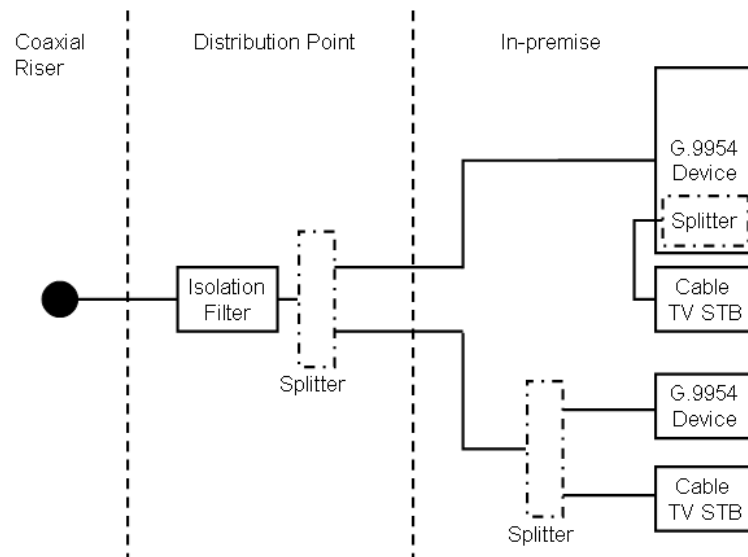

Figure 1-4a: Isolation Function

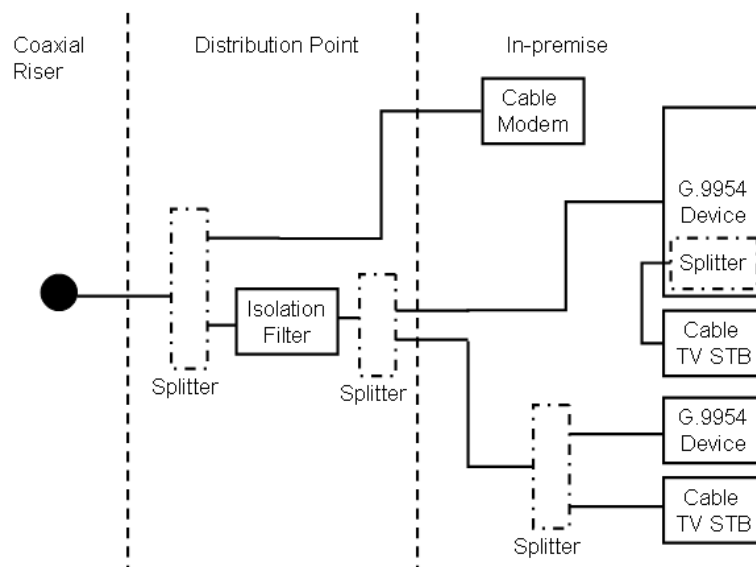

Figure 1-4b: Isolation Function (with Co-existence of DOCSIS)

- 1.8 The technical performance requirements of the broadband coaxial cable system as defined in COPIF 2008 Chapter 13 Section 2 SHALL be complied with after the introduction of the IF.

2 FREQUENCY AND POWER SPECTRAL DENSITY

2.1 Frequency Spectrum

The HNT SHALL operate in the Sub-mode F frequency spectrum from 52 to 68 MHz.

2.2 Isolation Filter Requirements

The IF shall be installed to (1) pass through broadcast FM and TV signals and cable TV signals; (2) provide isolation from Docsis network; and/or (3) isolate HNT from neighbours.

The IF shall minimally fulfil the specifications as provided in Table 2-2 and Figure 2-2 below.

S/N	Specification (w.r.t. 75 Ohm Impedance), f (MHz)	Min Requirements
1	Attenuation	
	$f \leq 42\text{MHz}$	$\leq 1\text{dB}^2$
	$42\text{MHz} < f < 52\text{MHz}$	$\geq (1 + (f-42)*40/10)\text{dB}$
	$52\text{MHz} \leq f \leq 68\text{MHz}$	$\geq 41\text{dB}$
	$68\text{MHz} < f < 85\text{MHz}$	$\leq (41 - (f-68)*40/17)\text{dB}$
	$f \geq 85\text{MHz}$	$\leq 1\text{dB}$
2	Return Loss	
	$f \leq 42\text{MHz}$	$\geq 12\text{dB}$
	$42\text{MHz} < f < 52\text{MHz}$	$\leq (12 - (f-42)*11/10)\text{dB}$
	$52\text{MHz} \leq f \leq 68\text{MHz}$	$\leq 1\text{dB}$
	$68\text{MHz} < f < 85\text{MHz}$	$\geq (1 + (f-68)*11/17)\text{dB}$
	$f \geq 85\text{MHz}$	$\geq 12\text{dB}$
3	Ripple	$\leq 2\text{dB}$

Table 2-2: Isolation Function (IF) Specifications

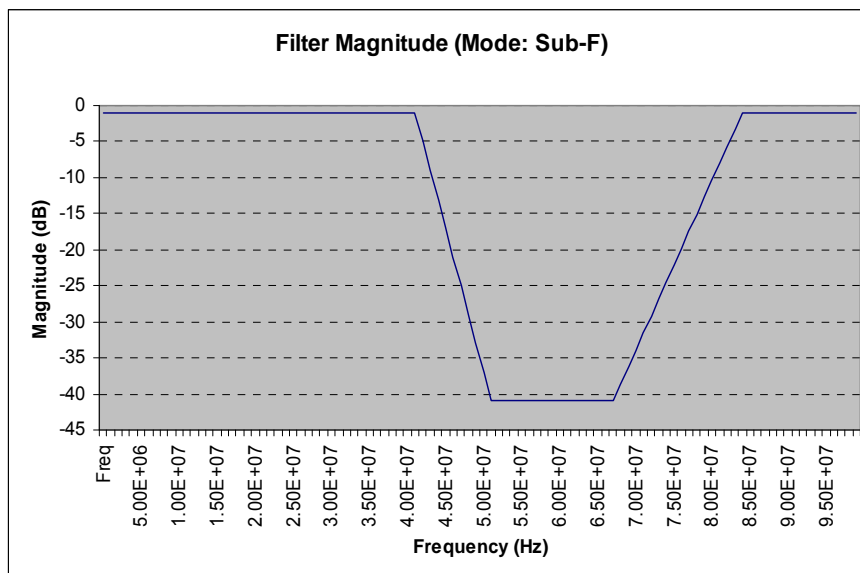

Figure 2-2: Isolation Function for Sub-Mode F (52~68 MHz)

² The filter may exclude 0 - 5MHz for the purpose of lightning/surge protection, if desired.

2.3 Spectral Masks

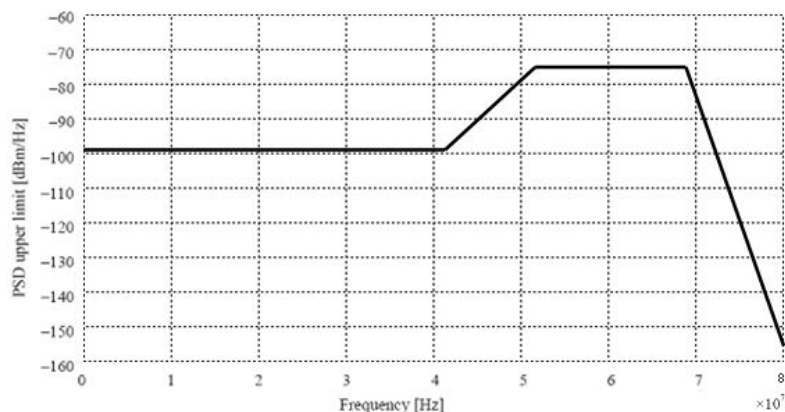

Figure 2-3: **Transmit PSD upper bound for sub-Spectral Mode F**

When transmitting in spectral sub-mode F, the resolution bandwidth used to make this measurement shall be 10 kHz for frequencies between 2.5 and 80.0 MHz, and 3 kHz for frequencies between 0.015 and 2.5 MHz. An averaging window of 213 seconds shall be used, and 1500-octet MTUs separated by an IFG duration of silence shall be assumed. A total of 50 kHz of possibly non-contiguous bands may exceed the limit line under 2.5 MHz, with no sub-band greater than 20 dB above the limit line. A total of 50 kHz of possibly non-contiguous bands may exceed the limit line between 80.0 and 100.0 MHz, with no sub-band greater than 20 dB above the limit line.

3 ELECTRICAL CHARACTERISTICS

3.1 Transmit Power

Stations shall transmit according to the transmit power limitations described in Table 3-1 (Table 7-7/G.9960), corresponding to the spectral mode they transmit. Transmit power shall be measured during the header, across a 75-ohm load between centre and ground, integrated from 0 to 100 MHz.

Spectral mode	Transmit power limit [dBm]
F	[-2 +1]

Table 3-1 (Table 7-7/G.9954): **Transmit Power Requirements**

3.2 Transmit Voltage

Stations that are not transmitting shall emit less than -85 dBVrms measured across a 75-ohm load between centre and ground.

4 RF Pass-through Port (Optional)

Where a secondary RF Pass-through Port is provided on the HNT device, the Pass through Port SHALL comply with the following specifications. The provision of the RF pass-through port is Optional.

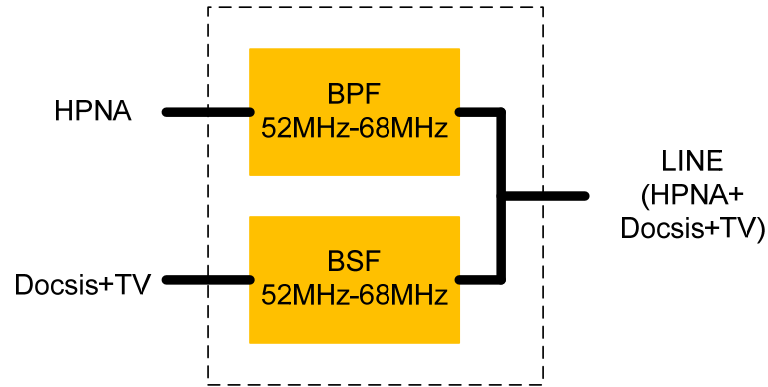

Figure 4: Pass-through Port (Diplexer Structure)

Port	Parameter	Frequency	Condition	Required Value
Line To HPNA	Insertion Loss	5MHz - 42MHz 52MHz - 68MHz 75MHz - 860MHz		>35dB <4dB >45dB
	Return Loss (Reflection)	52MHz - 68MHz	Measured from Line to HPNA Port. HPNA Port should be 75Ω Terminated.	>15dB
	Group Delay	52MHz - 68MHz		<100nSec
Line To DOCSIS + TV	Insertion Loss	5MHz - 42MHz 52MHz - 68MHz 75MHz - 860MHz		<2dB >45dB <2dB
	Return Loss (Reflection)	5MHz - 42MHz 75MHz - 860MHz	Measured from Line to DOCSIS/TV Port. DOCSIS/TV Port should be 75Ω Terminated.	>15dB >15dB
	Group Delay	5MHz - 42MHz 75MHz - 860MHz		<75nSec <25nSec
HPNA To DOCSIS + TV	Isolation	5MHz - 42MHz 75MHz - 860MHz		>40dB >45dB
DOCSIS + TV To HPNA	Isolation	52MHz - 68MHz		>45dB

Table 4: RF Pass-through Port (Optional) Requirements