

INFOCOMM MEDIA DEVELOPMENT AUTHORITY

TELECOMMUNICATIONS ACT

(CHAPTER 323)

GUIDELINES FOR INFO-COMMUNICATION FACILITIES IN BUILDINGS

DATE OF ISSUE: 28 NOVEMBER 2018

EFFECTIVE DATE: 15 DECEMBER 2018

1. INTRODUCTION
 2. GENERAL REQUIREMENTS FOR TELECOMMUNICATION FACILITIES
 3. GENERAL REQUIREMENTS FOR PROVISION OF SPACE AND FACILITIES
 4. PROCEDURES AND REQUIREMENTS FOR PROVISION OF MOBILE SERVICE COVERAGE WITHIN DEVELOPMENTS
 5. CABLE DISTRIBUTION SYSTEMS
 6. USER PREMISES CABLING AND INTERFACE POINTS
 7. INSTALLATION / UPGRADING OF THE ANTENNAE SYSTEM TO RECEIVE DIGITAL TERRESTRIAL TELEVISION/ FM RADIO
-
- APPENDIX 1 FUNCTIONS OF THE TELECOMMUNICATION FACILITY COORDINATION COMMITTEE AND BUILDING PLAN CO-ORDINATION AND APPROVAL PROCESS
- APPENDIX 2 DUCT SEALING SYSTEM FOR BUILDINGS WITH BASEMENT
- APPENDIX 3 TESTING AND ACCEPTANCE PROCEDURE FOR FACILITIES PROVIDED BY DEVELOPER OR OWNER

GUIDELINES FOR INFO-COMMUNICATION FACILITIES IN BUILDINGS

28 November 2018

The Info-communications Media Development Authority (“IMDA”), pursuant to Section 28 of the Telecommunications Act (Cap. 323) (“Act”), hereby issues these Guidelines for Info-Communication Facilities in Buildings (“Guidelines”).

1 INTRODUCTION

1.1 Obligations of developers or owners

- (a) These Guidelines detail the options available for specifications of the building space and facilities which developers or owners of buildings may select from to provide under the Code of Practice for Info-Communication Facilities in Buildings 2018 (“COPIF”) 2018, in order to enhance the range and/or quality of info-communication services that may be offered by telecommunication system licensees to the building(s). This document is to be read together with the COPIF which sets out the mandatory requirements in respect of the space and facilities which developers or owners are required to provide. Nothing in these Guidelines shall waive any developer or owner of its obligation to comply with the provisions of the COPIF. In the event of any conflict between the COPIF and these Guidelines, the provisions of the COPIF will prevail.
- (b) The specifications laid down in the Guidelines are based on existing policies and circumstances relating to the current and presently anticipated states of technological development, infrastructure deployment and service provision of the telecommunication system licensees. As such policies and circumstances may change with technological advancements and differing service demands, IMDA reserves the right to amend, add or remove any of the procedures, specifications and standards set out in these Guidelines from time to time.

1.2 Rules of Construction

Except where a term is specifically defined in these Guidelines, capitalised terms and words used in these Guidelines have the same meaning as in the COPIF.

1.3 Short Title

These Guidelines may be referred to as the “COPIF Guidelines”.

2 GENERAL REQUIREMENTS FOR INFO-COMMUNICATION FACILITIES

2.1 General

This chapter specifies the general requirements for the space and facilities provided in accordance with the COPIF, including the segregation of info-communication facilities from other utilities or services, diversity of lead-in and underground pipes, general and fire protections, joint inspection and acceptance of the space and facilities, and responsibilities of licensees and developers or owners.

2.2 Segregation requirements

(a) Non-electrical Plant

All manholes, underground pipes and cables for telecommunication services shall be kept clear of gas or water mains, service pipes and also isolated from manholes and joint boxes belonging to other services. The clearance shall be 150mm, but in difficult situations, it may be reduced to 50mm where the plant crosses each other. Where gas and water mains are concerned, a clearance of at least 150mm shall be maintained to permit the use of a pipe-threading machine. Underground plant, (including cables and pipes, crossing bridges constructed wholly or partly of steel) shall be insulated electrically from the steelwork throughout its entire length. Metal or PVC trunkings, tarmac and cement may be used.

(b) Electrical Plant

Requirements of the clearance to be provided between power and telecommunication cables are as follows:

- (i) For single-core power cables (exceeding 400V), the minimum clearance shall be 460mm, no exception being permitted.
- (ii) For multi-core power cables (exceeding 400V), the minimum clearance shall be 300mm. Where a clearance of 300mm cannot be obtained, a smaller clearance may be allowed. However, for clearances less than 150mm, a slab of concrete shall be inserted between the two sets of cables.
- (iii) For power cables (less than 400V), the minimum clearance shall be 50mm. If the clearance is less than 50mm, insulation sheets of non-combustible material with a thickness of 40mm shall be placed between the sets of cables.
- (iv) Telecommunication cables shall be separated from any electrical cables by separate casings, conduits, compartment ducts, etc. Where telecommunication and electrical cables intersect, a 'bridge' or suitable cross-over joint piece shall be provided.
- (v) In addition to (iv) above, where telecommunication and electrical cables are housed in trunking with multiple compartments, the trunking shall be designed to ensure that the cables remain in their individual compartments and the segregation between each compartment shall be continuous.

- (vi) All metal trunking and conduits shall be effectively earthed in accordance with the Singapore Standard SS551: Code of Practice for Earthing.
- (c) Multi-tiered cable tray

In the event that multi-tiered cable trays are used for various services, the bottommost cable tray shall be assigned to carry telecommunication cables. There shall also be a minimum of 100mm clearance between the cable tray assigned to carry telecommunication cables and the next cable tray(s).

2.3 Diversity

The COPIF 2018 contains a definite list of buildings housing vital services that must provide for diversity and resilience requirements (i.e., an additional set of lead-in pipes, main distribution frame (“MDF”) room, telecommunication riser and cable distribution system). However, where a building does not house vital services but the developer or owner opts to have diversity for its telecommunication services, an additional set of lead-in pipes, MDF room, telecommunication riser and cable distribution system should also be provided.

2.4 General protection

The space and facilities provided for telecommunication cables must be able to adequately protect the cables from possible damage caused by mechanical means, exposure to weather, corrosive fumes, water or excessive dampness, accumulated dust, steam, oil, high temperature or any other conditions which may damage the cables.

2.5 Fire protection

- (a) Water sprinkler systems must not be used in the MDF room, telecommunication equipment room and telecommunication risers. To comply with Singapore Civil Defence Force’s (“SCDF’s”) condition of waiver for such installation, the MDF room and telecommunication equipment room must be accessible directly from the outside of the building.
- (b) In addition, other forms of fire protection systems acceptable to the SCDF may be provided.

2.6 Facility record

For the purpose of maintenance and timely restoration of services in the event of breakdown, it is essential that the exact location of the lead-in and underground pipes, MDF room(s), telecommunication equipment room(s) telecommunication riser(s), cable tray routes and details of any other facilities provided by developers or owners within the building compound, such as location and dimension of manholes, are properly documented on plans. A laminated set or copy should also be displayed prominently and permanently inside the MDF room for easy reference during maintenance works.

2.7 Inspection procedure for completed space and facilities

- (a) Except where the provision of MDF room(s) is not required for certain types of building development under the COPIF, a written request shall be made to the Telecommunication Facility Co-ordination Committee (“TFCC”) for a joint site inspection upon the completion of the construction works. The written request shall be copied to IMDA. Please refer to Appendix 1 for the functions of the TFCC.
- (b) The joint site inspection shall be confined to the following space and facilities as may be applicable –
 - (i) MDF room(s);
 - (ii) telecommunication equipment room(s);
 - (iii) lead-in pipes and underground pipeline system;
 - (iv) telecommunication riser(s); and
 - (v) cable trays between the MDF room(s), telecommunication equipment room(s) and the telecommunication riser(s).
- (c) Where any space or facility is found to be non-compliant with the COPIF during the joint site inspection, such deficiency shall be recorded in the inspection checklist in Form 2.1, signed by the relevant parties and submitted to IMDA via the CORENET e-Submission system.
- (d) Where no deficiencies are recorded in the inspection checklist, an arrangement may be made with any licensee, whose services are required, to deploy its installation, plant or system in the relevant space and facilities for the provision of services to the building.
- (e) Where deficiencies are recorded in the inspection checklist, such deficiencies shall be rectified as soon as practicable before the deployment of installation, plant or system by licensees. However, an arrangement may be made for licensees to deploy concurrently their installation, plant or system in those space and facilities which do not require rectification works.
- (f) Once all deficiencies recorded in the inspection checklist are rectified, the declaration in Form 2.2 shall be submitted to IMDA via the CORENET e-Submission system.
- (g) A flow chart depicting the inspection process is set out in chart 2.3.
- (h) Nothing in this paragraph shall limit IMDA’s right to require the developer or owner of the building to rectify any space and facilities that are not constructed in accordance with the COPIF at any time and regardless of whether or not such space and facilities have been inspected under the procedure set out in this paragraph.

2.8 Responsibilities of the licensees

After handing over of the space and facilities to the licensees for their deployment of installation, plant and systems, the licensees shall be responsible for maintaining their installation, plant and systems and the general cleanliness of the space and facilities.

2.9 Responsibilities of the developers or owners of buildings

- (a) The developer or owner shall be responsible at its own expense for the provision and maintenance of all the facilities within the building, including but not limited to the facility records, cable trays, trunkings, lead-in and underground pipes, manholes, MDF room, telecommunication equipment room, mobile installation space and telecommunication risers, and for ensuring that they are in good serviceable condition and accessible to the licensees' personnel at all times;
- (b) The developer or owner shall assist the licensees at its own expense for drilling through concrete floor, ceilings or walls of buildings that form part of the facilities for telecommunication within the building; and
- (c) The developer or owner shall ensure at its own expense that adequate security measures are taken at the MDF room, telecommunication equipment room, mobile installation space and telecommunication risers to pre-empt trespassing by any unauthorised personnel. Under no circumstances should the MDF room, telecommunication equipment room and telecommunication risers be used for any other purpose such as a store room. The developer or owner shall hand over the MDF room, telecommunication equipment room and telecommunication risers to the licensees through the TFCC upon acceptance of the facilities by the licensees, for their deployment of telecommunication services.

2.10 Installation of telecommunication cables

- (a) The developer or owner may install and maintain its telecommunication cables for its own use or for access by its tenants or lessees.
- (b) The developer or owner shall engage wiring contractors, who are licensed by IMDA, to install telecommunication cables in its development. The developer or owner may also enter into a commercial arrangement with any licensee to install its telecommunication cables in its development.
- (c) However, in multi-tenanted buildings, tenants or lessees have the choice of getting any telecommunication licensee to provide any telecommunication services. A tenant or lessee may lease the telecommunication cables provided by the developer or owner based on commercial arrangements, or they may use the cables provided by a telecommunication licensee. The developer or owner shall allow any telecommunication licensee to install telecommunication cables within the building to serve any tenant or lessee, should the latter require the use of such cables.
- (d) For existing building, the developer or owner is required to refer and comply with the COPIF when planning or installing its own telecommunication cables. It should install its cables in a separate riser. However, in the absence of any

riser, prior approval from IMDA must be sought for using the telecommunication riser which is designated for the telecommunication licensees' use. IMDA may accede to the requests from the developer or owner to use the telecommunication riser where there is enough space for all users to share.

- (e) Notwithstanding paragraph 2.10(d), and for the avoidance of doubt, the developer or owner or its tenant must remove its telecommunication cables from the telecommunication risers at its own expense, if there is insufficient space for the telecommunication licensees' use.
- (f) Where the telecommunication risers are congested with cables, the developer or owner shall arrange at its own cost for its contractor to remove the unused cables which are left over by its former tenants so that there will be enough space for new cables to be laid. The developer or owner may, at its own expense and subject to the telecommunication licensee's agreement, allow the licensee to use an alternative communication riser and provide the licensee with full access to such a communication riser in the same manner as the access to be provided for telecommunication risers.

2.11 Do's and Don'ts for Earthworks

The developer or owner shall refer to the relevant telecommunication system licensee's list of "Do's and Don'ts" in relation to the reasonable precautions to be taken when carrying out any earthworks to prevent any damage to such telecommunication system licensee's telecommunication cable.

FORM 2.1

Date: [dd-mmm-yyyy]

Infocomm Media Development Authority
10 Pasir Panjang Road
#03-01 Mapletree Business City
Singapore 117438

Attn: Director
Interconnection & Access

Dear Sirs

**CODE OF PRACTICE FOR INFO-COMMUNICATION FACILITIES IN BUILDINGS –
NOTIFICATION OF COMPLETION OF INSPECTION OF SPACE AND FACILITIES**

PROJECT REFERENCE NO:
PROJECT TITLE:
BUILDING ADDRESS/ SITE:
BUILDING NAME:
TFCC Reference No.:

I refer to the inspection conducted jointly between my representatives and representatives from the Telecommunication Facility Co-ordination Committees (“TFCC”) on [dd-mmm-yyyy].

In accordance with the requirement of the Code of Practice for Info-communication Facilities in Buildings, the endorsed joint inspection checklist is enclosed for IMDA’s information.

Yours faithfully

[Developer or owner’s name]

Encl

FORM 2.1 (CONT'D)**CODE OF PRACTICE FOR INFO-COMMUNICATION FACILITIES IN BUILDINGS -
INSPECTION CHECKLIST FOR SPACE AND FACILITIES**

PROJECT TITLE: _____

TFCC REFERENCE NO.: _____

1. The dimension and quantities of the space and facilities required to be provided are as follows:

(a) Main Distribution Frame (MDF) room

MDF room	Length	Width	Height	Number of lead-in pipes
MDF room (1)				
MDF room (2)				

(b) Telecommunication Equipment Room (TER)

TER	Length	Width	Height	Number of lead-in pipes
TER (1)				
TER (2)				

(c) Telecommunication riser

Telecom riser	Length	Width	Height
Telecom riser (1)			
Telecom riser (2)			

2. The as-built dimensions and quantities of the space and facilities constructed are as follows:

(a) Main Distribution Frame (MDF) room

MDF room	Length	Width	Height	Number of lead-in pipes
MDF room (1)				
MDF room (2)				

FORM 2.1 (CONT'D)

**CODE OF PRACTICE FOR INFO-COMMUNICATION FACILITIES IN BUILDINGS -
INSPECTION CHECKLIST FOR SPACE AND FACILITIES**

PROJECT TITLE: _____

TFCC REFERENCE NO.: _____

(b) Telecommunication Equipment Room (TER)

TER	Length	Width	Height	Number of lead-in pipes
TER (1)				
TER (2)				

(c) Telecommunication riser

Telecom riser	Length	Width	Height
Telecom riser (1)			
Telecom riser (2)			

(d) Underground pipes

Comment:

(e) Cable trays

Comment:

3. The joint inspection was conducted in the presence of:

(a) Developer or owner's Representative _____

Signature/Date _____

(b) TFCC Member (1) _____

Signature/Date _____

(c) TFCC Member (2) _____

Signature/Date _____

(d) TFCC Member (3) _____

Signature/Date _____

FORM 2.2

Date: [dd-mmm-yyyy]

Infocomm Media Development Authority
10 Pasir Panjang Road
#03-01 Mapletree Business City
Singapore 117438

Attn: Director
Interconnection & Access

Dear Sirs

**CODE OF PRACTICE FOR INFO-COMMUNICATION FACILITIES IN BUILDINGS –
NOTIFICATION OF RECTIFICATION OF DEFECTS IN SPACE AND FACILITIES**

PROJECT REFERENCE NO:
PROJECT TITLE:
BUILDING ADDRESS/ SITE:
BUILDING NAME:
TFCC Reference No.:

I refer to my letter titled “Code of Practice for Info-communication Facilities in Buildings – Notification of Completion of Inspection of Space and Facilities” dated [dd-mmm-yyyy] and IMDA’s letter dated [dd-mmm-yyyy].

I hereby declare and confirm that I have rectified all defects identified during the joint inspection. The as-built dimensions and quantity of the space and facilities provided are enclosed for IMDA’s information.

Yours faithfully

[Developer or owner’s name]

Encl

FORM 2.2 (CONT'D)**CODE OF PRACTICE FOR INFO-COMMUNICATION FACILITIES IN BUILDINGS -
INSPECTION CHECKLIST FOR RECTIFICATION OF DEFECTS IN SPACE AND
FACILITIES**

PROJECT TITLE: _____

TFCC REFERENCE NO.: _____

1. The dimension and quantities of the space and facilities required to be provided are as follows:

(a) Main Distribution Frame (MDF) room

MDF room	Length	Width	Height	Number of lead-in pipes
MDF room (1)				
MDF room (2)				

(b) Telecommunication Equipment Room (TER)

TER	Length	Width	Height	Number of lead-in pipes
TER (1)				
TER (2)				

(c) Telecommunication riser

Telecom riser	Length	Width	Height
Telecom riser (1)			
Telecom riser (2)			

2. The as-built dimensions and quantities of the space and facilities constructed and as rectified are as follows:

(a) Main Distribution Frame (MDF) room

MDF room	Length	Width	Height	Number of lead-in pipes
MDF room (1)				
MDF room (2)				

FORM 2.2 (CONT'D)**CODE OF PRACTICE FOR INFO-COMMUNICATION FACILITIES IN BUILDINGS -
INSPECTION CHECKLIST FOR RECTIFICATION OF DEFECTS IN SPACE AND
FACILITIES**

PROJECT TITLE: _____

TFCC REFERENCE NO.: _____

(b) Telecommunication Equipment Room (TER)

TER	Length	Width	Height	Number of lead-in pipes
TER (1)				
TER (2)				

(c) Telecommunication riser

Telecom riser	Length	Width	Height
Telecom riser (1)			
Telecom riser (2)			

(d) Underground pipes

Comment:

(e) Cable trays

Comment:

CHART 2.3
INSPECTION PROCESS FLOWCHART

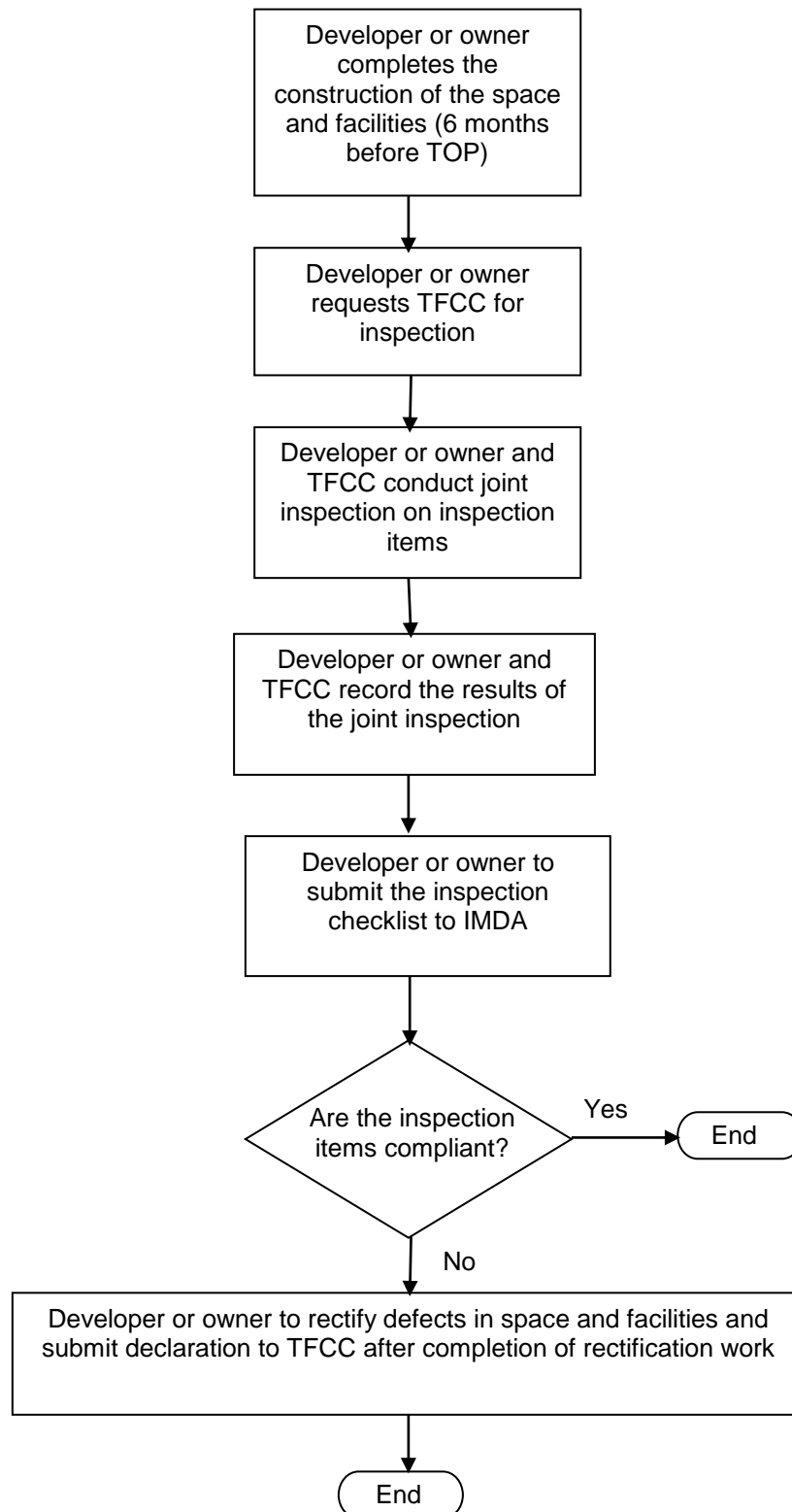

3 GENERAL REQUIREMENTS FOR PROVISION OF SPACE AND FACILITIES

3.1 Documentation

- (a) A set of as-built installation drawings for any telecommunication cable system shall be prepared by the developer or owner for each building type as specified in Chapters 4 to 10 of the COPIF, in the format (e.g. BIM) required by the relevant authority. The drawings shall show the cable routes and distances, outlet identification, detailed drawings of distribution panels, and other data that might be useful in carrying out maintenance and repair.
- (b) All legends and symbols in the as-built drawings shall be properly indicated. Upon request by the licensee, a copy of these drawings shall be provided to them.

4 PROCEDURES AND REQUIREMENTS FOR PROVISION OF MOBILE SERVICE COVERAGE WITHIN DEVELOPMENTS

4.1 General

- (a) Mobile telecommunication licensees operating public cellular mobile telecommunication systems may face difficulty in providing mobile service coverage within developments, including basement levels and underground pedestrian malls, as building design and structure would affect the radio propagation characteristics. The difficulty faced by licensees in providing mobile service coverage within developments is particularly significant where building structures use materials unfavourable to radio signal penetration, e.g. metallic wall cladding, metallised window film. As such, it may take up to a year or more for licensees to plan and deploy their installation, plant and system in the development so as to provide mobile service coverage within the development.
- (b) This chapter serves to inform the developer or owner of any development of the procedures and requirements to facilitate the timely provision of mobile service coverage within the development.

4.2 Responsibility of developer or owner

These guidelines do not exempt the developer or owner from obtaining:

- (a) Licences from the relevant authorities to install and operate radio equipment; and
- (b) Approvals from the relevant authorities for installation of physical structures and reinforcements to support antennae and other equipment, where necessary.

4.3 Procedures and requirements for the provision of mobile service coverage

- (a) The developer or owner may make a written request to any licensee for the provision of mobile service coverage within the development, and shall include in such written request relevant information relating to the development (e.g. type and size of the development).
- (b) The developer or owner shall provide reasonable access to its premises for licensees to conduct survey and field tests to determine the extent of mobile service coverage within the development.
- (c) Where the licensee agrees to provide or enhance mobile service coverage within the development and the developer or owner wishes to facilitate the timely provision or enhancement of mobile service coverage, the developer or owner may, unless otherwise agreed with the licensee:
 - (i) provide antennae support structure (including mounting poles with appropriate spacing between poles) at the roof-top or suitable external walls of a building, where the antennae are to be installed at the roof-top;

- (ii) provide a cable distribution system (with specifications to be consulted with the licensees) across the ceiling for each floor including all basement floors;
- (iii) provide separate sets of electrical distribution panels operating on a minimum power supply of 230V, 32A (3-phase) isolators for each licensee at the mobile installation space;
- (iv) provide other facilities (e.g. drilling of holes between uppermost floor and the roof-top) as the licensee may request; and
- (v) site the mobile installation space in a location that:
 - (A) would facilitate optimal signal distribution for the provision of good mobile coverage;
 - (B) is in close proximity to the power supply source and communication and transmission links;
 - (C) is properly secured to prevent unauthorised access; and
 - (D) has sufficient ventilation and lighting, and is free of hazards to workers.

5 CABLE DISTRIBUTION SYSTEMS

5.1 General

- (a) Cable distribution systems are the facilities provided to distribute telecommunication cables installed from the MDF room or telecommunication equipment room to the telecommunication risers and from telecommunication risers to each residential or non-residential unit.
- (b) The design and capacity of the distribution system shall be flexible enough to accommodate any re-arrangement of premises layout or the changing telecommunication needs of the building tenants.
- (c) A properly designed distribution system will ensure that cables can be installed or changed at any time, with minimum inconvenience caused to the building tenants and without affecting the structure or appearance of the building.
- (d) The types of cable distribution system that can be used in a building generally depend on the types of building. Buildings can broadly be categorised into residential and non-residential buildings.
- (e) The types of cable distribution system suitable for use in a non-residential building can either be concealed or exposed.
 - (i) Examples of **Concealed distribution systems** are:
 - (A) Under-floor duct distribution system;
 - (B) Raised floor system;
 - (C) Cellular floor distribution system;
 - (D) Ceiling distribution system;
 - (E) Perimeter raceway distribution system;
 - (F) Poke-through distribution system; and
 - (G) Conduit distribution system.

Note: Certain non-residential buildings may require a combination of two or more of the abovementioned systems for distributing telecommunication cables.

- (ii) Examples of **Exposed distribution systems** are:
 - (A) Cable tray; and
 - (B) Exposed conduit.

Note: Exposed distribution systems are normally used in places where concealed distribution systems are not practical or where aesthetics is not important.

(f) For residential buildings, suitable types of distribution system are as follow:

- (i) Under floor distribution system;
- (ii) Perimeter raceway distribution system;
- (iii) Ceiling distribution system; and
- (iv) Multi-riser system.

Note: Certain residential buildings may have a combination of two or more of the abovementioned systems for distributing telecommunication cables.

(g) **Capacity of distribution system**

It is important to note that for all the systems mentioned, the practical capacity of a raceway, be it a duct, a conduit or a trunking is considerably less than the theoretical capacity. This is because the helix of the cable is normally retained even when the cables are unwound, thereby causing the cables to wrap round one another and occupy a larger area of the raceway than the theoretical value.

(h) **Identification of distribution system**

To identify and differentiate the telecommunication cable distribution system from cabling facilities for other utilities/services, all ducts, cable trays, trunking, conduits, etc. for distributing telecommunication cables shall be painted white and labelled "Telecommunications".

(i) **Surface cabling**

It is important to note that for concealed cables that become defective after installation and are not accessible, the telecommunication system licensees or wiring contractors shall replace the cables using the surface cabling method, unless additional facilities suitable for concealed cabling are provided.

(j) **Segregation of cabling systems**

It is important to segregate the cabling systems to accommodate different types of telecommunication cables (e.g. coaxial and non-coaxial cables) to minimise the possibility of any interference.

(k) **Earthing of metal parts**

All metal parts of the distribution system shall be effectively earthed complying with the following standards:

- (i) Singapore Standard CP5: Code of Practice for Electrical Installations; and
- (ii) Singapore Standard SS551: Code of Practice for Earthing.

5.2 Cable distribution systems for non-residential buildings

The requirements of the various types of distribution system suitable for use in non-residential buildings are listed in the following paragraphs.

(a) Under-floor duct distribution system for non-residential buildings

(i) General –

- (A) A properly designed under-floor duct distribution system is a good method for distributing telecommunication cables (Figure 5.2).
- (B) The under-floor duct distribution system suitable for use in non-residential buildings may be designed with total access or with junction box access.
- (C) An under-floor duct distribution system designed with total access throughout its entire length to enable easy installation and maintenance of cables is known as the trench duct system (Figure 5.3).

(ii) Basic requirements –

- (A) The under-floor duct should extend into the telecommunication riser and link to the floor trench (Figures 5.4 and 5.5).
- (B) The under-floor duct distribution system should be designed to enable access with little or no disruption to the tenants. Access to the system should be from the floor it is designed to serve, and not from the adjacent floor.
- (C) The under-floor duct distribution system should be designed with the main junction boxes along the common corridor area or passageway (Figure 5.6).
- (D) The under-floor duct distribution system should be free from internal roughness, sharp edges, moisture and dirt.
- (E) The under-floor duct distribution system should be provided with floor outlets to lead the telecommunication cables out of the ducts (Figure 5.7).
- (F) For an under-floor duct distribution system with junction box access, the thickness of the floor screed on top of the ducts should not exceed 40 mm for ease of carrying out cabling work.

(iii) Duct –

- (A) The size of the under-floor duct should be such that the cross-sectional area of all the cables accommodated within a duct does not exceed 30% of the cross-sectional area of the duct.
- (B) The under-floor duct should be made of either high impact rigid PVC or galvanised metal or steel of welded construction and of sufficient thickness.

- (C) The under-floor duct should be of a minimum internal height of 25mm.
 - (D) A nylon draw wire should be provided in the duct between every two adjacent junction boxes.
- (iv) Junction boxes –
- (A) The under-floor duct distribution system should be provided with junction boxes at all junctions and bends to enable drawing of telecommunication cables. The distance between two junction boxes in a straight run should preferably not exceed 6m (Figure 5.8).
 - (B) Where it is not practical to have a junction box at a bend, the bend should have a minimum radius of about six times the width of the duct.
 - (C) The size of the junction box should increase proportionately with that of the floor ducts.
 - (D) The cover of the junction box should preferably be square. Junction box cover should be secured to the junction box by means of screws or other acceptable means (Figure 5.9). The screws should remain intact on the junction box cover when the cover is removed.
 - (E) The junction box cover should be as close-fitting as possible and flushed with the floor surfaces. The cover should be sufficiently robust to resist damage by floor cleaning equipment.
 - (F) All junction boxes and floor outlets should be readily accessible at all times. Walls or partitions should not be constructed on top of them (Figure 5.10).
 - (G) For carpeted floors, appropriate slits should be made on the carpet at all junction boxes and floor outlets to enable access to the under-floor ducts. Figure 5.11 illustrates one method of providing the access to the junction box for carpeted floors.
 - (H) Under special circumstances, the junction-box cover may be cut to accommodate the floor outlets except in common areas that are prone to washing or mopping (e.g., common corridors and lift lobby areas). Any cutting required on a junction-box cover should be done along the edges of the cover.
- (v) Responsibility of developer or owner: -
- The developer or owner should install and maintain the outlets and junction boxes.
- (vi) The advantages of an under-floor duct distribution system are as follows –
- (A) Cables are well protected in the ducts, therefore interruption of service caused by physical damage to cables is minimised;

- (B) Appearance of the premises is enhanced as the ducts are concealed under the floor screed; and
 - (C) Safe and easy working position.
- (vii) The disadvantages of an under-floor duct distribution system are as follows: -
- (A) Difficult to access junction boxes or header ducts when floor is covered with carpet; and
 - (B) Water can seep through the junction boxes and damage the cables.
- (b) **Raised floor distribution system for non-residential buildings**
- (i) General –
 - (A) A raised floor distribution system is a floor assembly superimposed on an existing floor. Telecommunication cables are distributed in the space between the floor and raised floor assembly (Figure 5.12).
 - (B) A raised floor distribution system is usually used in computer rooms and offices with a high number of telecommunication cables.
 - (C) The floor assembly consists of a series of square modules of steel plates or panels or concrete slabs resting upon pedestals (Figure 5.13).
 - (ii) Basic requirements: -
 - (A) The raised floor panels should be supported on pedestals that are of a height sufficient to ensure a clear working space of at least 25mm below the floor panel.
 - (B) Trunking or cable trays should be provided to segregate telecommunication cables from electrical cables and cables of other services placed below the raised floor.
 - (iii) The responsibilities of the developer or owner are as follows: -
 - (A) The developer or owner should provide concealed floor fittings or suitable outlets for the telecommunication cables.
 - (B) The developer or owner should provide the trunking or cable trays required to segregate telecommunication cables from electrical cables and cables of other services placed below the raised floor (Figure 5.14).
 - (C) The developer or owner should be responsible for removing and replacing floor panels.
 - (D) The developer or owner should possess the necessary fitting devices for removing or replacing the floor panels.
 - (iv) The advantages of a raised floor distribution system are as follows: -

- (A) Cables are well protected below the raised floor, therefore interruption of service caused by physical damage to cables is minimised;
 - (B) Appearance of the premises is enhanced as the cables are concealed under the floor;
 - (C) Safe and easy working position;
 - (D) Any change in telecommunication requirements can be easily catered for; and
 - (E) Ability to accommodate a large number of cables.
- (v) The disadvantages of a raised floor distribution system are as follows: -
- (A) It is costlier to provide the system comparing with other distribution systems;
 - (B) The system may produce sound when walked upon; and
 - (C) Broadloom carpet cannot be used.
- (c) **Cellular floor distribution system for non-residential buildings**
- (i) General –
 - (A) A cellular floor distribution system serves as a structural floor as well as a system for distributing telecommunication cables and cables of other services. Figure 5.15 shows the different compartments of a typical cellular floor system.
 - (B) The cellular floor distribution system comprises the distribution cells, which are mainly constructed of steel but concrete distribution cells can also be used, and header duct or trench header, which are used to link the distribution cells to the telecommunication riser.
 - (C) The cellular floor distribution system is basically a two-level system with the distribution cells on the lower level and header duct or trench header on the upper level.
 - (D) The layout of the distribution system and the design of the structural floor and its supporting members should be integrated.
 - (ii) Cellular floor system with header duct –
 - (A) A header duct is installed on top of the distribution cell. It provides permanent and ready access to distribution cells which run at a right angle to it.
 - (B) Junction boxes are provided on the header duct.
 - (C) Since the header duct is the link between the distribution cells and the telecommunication riser, it is important that adequate capacity be provided.

- (iii) Cellular floor system with trench header: -
 - (A) A trench header is a metallic trough that is flushed with the finished floor. It provides permanent and ready access to distribution cells that run at right angle to it.
 - (B) A trench header is equipped with removable steel cover plates for its entire length.
 - (C) If the trench header has two or more compartments to distribute cables of different services such as power and telecommunication, the segregation is maintained throughout the trench header.
- (iv) Basic requirements: -
 - (A) The main trench header or header duct should be installed along the common corridor of the building and made accessible at all times.
 - (B) No partition should be constructed on top of the trench header or the junction box of the header duct.
 - (C) The number of preset insert units provided should meet the telecommunication needs of the building. Generally, it is recommended that every 1.8 m² of the floor space should have at least one preset insert unit.
- (v) The responsibilities of the developer or owner are as follows: -
 - (A) The developer or owner should remove the covers of the trench header and any furniture resting on the covers, when installation or maintenance of telecommunication cables in the distribution system is being carried out.
 - (B) The developer or owner should possess the necessary equipment for removing trench header covers and detecting the preset insert units.
 - (C) The developer or owner should locate and make available the individual preset insert unit connected to the cell to enable installation of telecommunication cables.
 - (D) The developer or owner should undertake to drill the concrete floor and install after-set inserts at locations where telecommunication services are required and preset insert units are not available.
- (vi) The advantages of a cellular floor system are as follows: -
 - (A) Cables are well protected in the cells, trench headers and header ducts, therefore interruption of service caused by physical damage to the cables is minimised;
 - (B) Appearance of the premises is enhanced as the trench or duct and the cells are concealed in the floor slab;

- (C) Safe and easy working position; and
 - (D) The system can distribute a large number of cables.
- (vii) The disadvantages of a cellular floor system are as follows: -
- (A) More coordination is required. This is because the preset insert units need to be located prior to installation of telecommunication services; and
 - (B) Water can seep through the distribution cells and damage the telecommunication cables.
- (d) **Ceiling distribution system for non-residential buildings**
- (i) General: -
 - (A) The ceiling distribution system can be used when there is adequate ceiling space. The system comprises cable trays/trunking, conduits and/or utility poles (Figure 5.16).
 - (B) In a ceiling distribution system, telecommunication cables are laid onto cable trunking or laid and tied with cable ties onto the cable trays within the ceiling space and routed to the telecommunication outlets by means of conduits or utility poles.
 - (ii) Basic requirements: -
 - (A) Where cable trays/trunking/conduits are concealed in false ceilings of ceiling strips or boards that are not easily accessible, access panels should be provided for easy and unrestricted access to the cable trays (Figure 5.17).
 - (B) The dimension of the access panels should not be less than 600mm x 600mm, and they should preferably be provided at regular intervals of 6m as well as at positions where there is a change in the direction of the cable trays/trunking/conduits.
 - (C) The passage between the ceiling trays/trunking and the ceiling slabs should ideally be free from obstructions such as air-conditioning ducts, fire sprinklers, electrical trunking, water pipes, etc. When obstructions are unavoidable, a minimum clearance as indicated in Figure 5.18 should be maintained.
 - (D) The cable trays and trunking should be in accordance with the specifications described in paragraphs 5.2 (h) and 5.2 (j) respectively.
 - (E) 'L' brackets used for supporting cable trays should be installed in the same direction.
 - (iii) Responsibility of developer or owner

The developer or owner should be responsible for removing and replacing ceiling boards.

- (iv) The advantage of a ceiling distribution system is that it provides a flexible mean of distributing telecommunication cables to specific locations.
 - (v) The disadvantages of ceiling distribution system are as follows: -
 - (A) Ceiling boards must be made removable, and there is a high possibility of them being damaged or tainted due to frequent removal and replacement of these boards; and
 - (B) It may cause disruption to the tenants and environment when telecommunication cables installation or maintenance work is being carried out.
- (e) **Perimeter raceways distribution system for non-residential buildings**
- (i) General
 - (A) Perimeter raceways are ducts or trunking installed along the perimeter of a room, shop or an office to distribute and conceal telecommunication cables.
 - (B) The perimeter raceway ducts or trunking are either surface mounted or recessed into the base of the wall to form a skirting.

They can also be mounted at any height along the wall provided that these raceways will not be obstructed by signboards, etc., to be erected by potential tenants or shop-owners (Figures 5.19, 5.20 and 5.21).
 - (C) The ducts and trunking can be constructed of metal, plastic or wood.
 - (D) Perimeter raceways come in various sizes and may be divided into two or more compartments to accommodate power, telecommunication and cables of other services (Figure 5.22).
 - (E) A sleeve through the wall can be used to connect telecommunication outlets in adjacent rooms that are on the same floor.
 - (ii) Basic requirements
 - (A) The perimeter raceways should be provided with removable covers placed at a regular interval of 2m. The telecommunication outlets should preferably remain intact on the raceway when the covers are removed.
 - (B) Multi-compartment perimeter raceways should be designed to ensure that electrical cables will remain in their compartments when the covers are removed.
 - (C) Fittings for mounting telecommunication outlets should be provided.
 - (D) If telecommunication cables cross the compartment for electrical cables, a "cross-over" or "bridge" must be provided to maintain segregation.

(iii) Responsibility of developer or owner: -

The developer or owner should be responsible for removing any object that may obstruct the removal of the covers from the raceways.

(iv) The advantages of a perimeter raceway system are as follows: -

(A) It can serve both as a skirting and a raceway for routing cables.

(B) Telecommunication outlets may be conveniently placed anywhere along the raceway.

(v) The disadvantages of a perimeter raceway system are as follows: -

(A) Extensive use of this system is made difficult by the columns and doors in the buildings; and

(B) It is only suitable for premises where the telecommunication outlets are placed near the wall. In large offices where telecommunication outlets are required in the centre of the offices, other types of distribution system such as under-floor ducts need to be incorporated (Figure 5.23).

(f) **Poke-through distribution system for non-residential buildings**

(i) General

(A) In poke-through distribution systems, the telecommunication cables are concealed in conduits or laid on cable trays/trunking placed within the ceiling space and are poked through the floor structure to the offices or shops above (Figure 5.24).

(B) This poke-through distribution system is vulnerable to the spreading of fire, gases, and smoke from floor to floor. Therefore, the use of this system must comply with any relevant requirement specified in the fire safety code published by the relevant authority.

(ii) The poke-through distribution system has many disadvantages and is therefore not recommended for use. When holes are drilled through the floor slab, the following may occur:

(A) Allow the passage of liquid and dirt to the floor below.

(B) Cause the spreading of fire, gases and smoke from floor to floor.

(C) Cause disturbance to tenants on the lower floor while workmen are providing and maintaining telecommunication services to tenants on the floor above.

(g) **Conduit distribution system for non-residential buildings**

(i) General

(A) Conduits can be used to distribute cables in those parts of a building where the telecommunication usage density is low and

flexibility in relocating the telecommunication outlets is not required. Examples of such areas of a building are guest rooms in a hotel and patient rooms in a hospital.

- (B) The telecommunication outlets in the hotel guest rooms and hospital patient rooms can be fixed and are unlikely to change in position. Conduits are used to distribute the telecommunication cables to each room (Figure 5.25).
 - (C) Other types of distribution systems such as the under-floor duct system are used to serve the other areas of the building, e.g., administration office, where flexibility in relocating telecommunication outlets is required.
- (ii) Basic requirements
- (A) The size of the conduit should be such that the cross-sectional area of all the cables placed in the conduit does not exceed 30% of the cross-sectional area of the conduit. The recommended capacities for conduits are as shown in Table 5.1.

Table 5.1 Recommended capacities for conduits

Conduit Size (mm)	Recommended number of cables							
	4-way	6-way	8-way	5-pair	10-pair	20-pair	40-pair	80-pair
25	6	4	4	2	1	1	0	0
32	10	7	6	4	2	1	1	0
38	15	11	9	7	4	2	1	0
50	-	-	-	-	7	5	2	1

- (B) Conduits should preferably be at least 25mm in diameter.
- (C) Conduits provided should be as straight as possible and should be rigidly mounted.
- (D) Conduits should be provided with junction boxes to enable drawing of telecommunication cables. The distance between two junction boxes in a straight run should preferably not exceed 6m. A junction box should also be provided at every junction and bend.
- (E) Where it is not practical to have a junction box at a bend, the bend should have a minimum radius of about six times the internal diameter of the conduit. Not more than one such bend is allowed between two junction boxes and the distance between them should preferably be not more than 2m.
- (F) A nylon draw rope should be provided in the conduit between every two junction boxes to enable the drawing of cables.
- (G) Flexible conduits should not be used.
- (H) Conduits should be free from internal roughness, sharp edges, moisture and dirt.

(h) Cable trays**(i) Basic requirements**

- (A) The material used for the cable tray should be perforated and galvanised;
- (B) All cable trays should be aligned and securely mounted;
- (C) Cable trays should not be routed through toilets, high-tension (HT) switch rooms, and other non-accessible areas;
- (D) Cable trays should be straight run, and for any change in direction, the bend should have a minimum radius of 600mm (Figure 5.26);
- (E) No bolts, screws or sharp objects should protrude through the cable-bearing surface of the trays;
- (F) The cable tray support must be L-shaped or inverted T-shaped;
- (G) Where cable trays run alongside or across electrical cables, they should be separated for their entire length by a clearance as specified in Chapter 2, paragraph 2.2 of these Guidelines. The electrical cables should be clearly indicated by signs or symbols;
- (H) The minimum clearance between ceiling/beam and cable tray should be 300mm;
- (I) For cable trays installed within false ceilings, there may be instances that require the cable trays to be replaced with pipes for easy installation of cables. For such cases, access must be provided in the false ceilings at appropriate locations;
- (J) Slots provided in the wall for cable trays to go through should have a minimum height of 300mm; and
- (K) Where cable trays are concealed in false ceilings, the panels of the false ceiling should be fully and easily removable to allow unrestricted access.

(i) Exposed conduits/ trunking**(i) General –**

- (A) The requirements for conduits, mounted and exposed along walls, are similar to conduits that are concealed under-floor or in the ceiling. Please see paragraph 5.2 (g) for detailed requirements.

(j) Concealed cabling in office furniture**(i) General –**

Office furniture with built-in channels to conceal cables is becoming more common. This furniture includes not only free-standing desks, but also flexible screens that are fitted adjacent to the desks and which can accommodate shelving, etc.

- (ii) To ensure a safe and efficient system, this office furniture should meet the following basic requirements:
- (A) The cable channel should be easily accessible for the installation of cables by the telecommunication system licensees' or the tenants' wiring contractors;
 - (B) Segregation of telecommunication cables and power cables should be maintained;
 - (C) If metal channels or ducts are used, they should be installed and earthed according to the Singapore Standards: CP5: 'Code of Practice for Electrical Installations' and SS551: 'Code of Practice for Earthing';
 - (D) When the cable channels are part of a flexible screen, the cable across the flexible junction between the screen panels should be protected and flexing of the panels should be prevented after the cables have been installed;
 - (E) The furniture should be positioned as close to the socket outlets as possible; and
 - (F) Once the cables are installed, movement of the furniture should be minimised.

(k) **Suitable distribution systems for various types of premises**

The suitable distribution systems for various premises are as shown below in Table 5.2.

Table 5.2 Suitable distribution systems for various types of premises

Types of Premises	Types of Distribution System					
	Under-floor Duct	Raised Floor	Cellular Floor	Ceiling Distribution	Exposed Cable Tray / Trunking	Exposed Conduit
Shop-houses Without Management Corporation				✓	✓	✓
Shop-houses in HDB Residential Blocks				✓	✓	✓
Shopping Centres	✓			✓	✓	✓
Office Complexes	✓	✓	✓	✓	✓	✓
Factories (Terrace & Flatted)	✓			✓	✓	✓
Markets, Hawker/Food Centres				✓	✓	✓

(l) Concealed cabling in office furniture**(i) General –**

Office furniture with built-in channels to conceal cables is becoming more common. This furniture includes not only free-standing desks, but also flexible screens that are fitted adjacent to the desks and which can accommodate shelving, etc.

(ii) To ensure a safe and efficient system, this office furniture should meet the following basic requirements:

- (A)** The cable channel should be easily accessible for the installation of cables by the telecommunication system licensees' or the tenants' wiring contractors;
- (B)** Segregation of telecommunication cables and power cables should be maintained;
- (C)** If metal channels or ducts are used, they should be installed and earthed according to the Singapore Standards: CP5: 'Code of Practice for Electrical Installations' and SS551: 'Code of Practice for Earthing';
- (D)** When the cable channels are part of a flexible screen, the cable across the flexible junction between the screen panels should be protected and flexing of the panels should be prevented after the cables have been installed;
- (E)** The furniture should be positioned as close to the socket outlets as possible; and
- (F)** Once the cables are installed, movement of the furniture should be minimised.

5.3 Cable distribution systems for residential buildings

The requirements of the various types of distribution system suitable for use in residential buildings are listed in the following paragraphs.

(a) Under-floor distribution system for residential buildings**(i) General –**

- (A)** Under-floor distribution system suitable for use in residential buildings is constructed of either ducts, conduits, or a combination of both.
- (B)** At common corridor areas, the ducts or conduits are laid in the floor slab to distribute cables from the telecommunication riser. Junction boxes are provided at all junctions and bends (Figure 5.28).
- (C)** Within each residential unit, conduits are used to distribute the cables to various telecommunication outlets in each room (Figure 5.29).

- (ii) Basic requirements –
 - (A) The duct or conduit at common corridor areas should extend into the telecommunication riser (Figure 5.30).
 - (B) For joint-usage with electrical cables, a separate compartment should be provided for telecommunication cables. The segregation requirements should be in accordance with chapter 2, paragraph 2.2 of these Guidelines.
 - (C) Under-floor ducts or conduits should be made of either galvanised metal or high impact rigid PVC.
 - (D) The duct or conduit should be free from internal roughness, sharp edges, moisture or dirt.
 - (E) The thickness of the floor screed on top of the ducts should not exceed 40mm for ease in carrying out cabling work.
- (iii) Common corridor area –
 - (A) The system should be provided with junction boxes at all junctions and bends to enable drawing of telecommunication cables. The distance between two junction boxes in a straight run should preferably not exceed 6m (Figure 5.8).
 - (B) Where it is not practical to have a junction box at a bend, the bend should have a minimum radius of about six times the internal diameter of the conduit or six times the width of the duct, whichever is applicable. Not more than one such bend is allowed between two junction boxes.
 - (C) The size of the junction box should increase proportionately with that of the floor ducts.
 - (D) The cover of the junction box should preferably be square. Junction box covers should be secured to the junction box by means of screws or other means acceptable to the telecommunication system licensee. The screw should remain intact on the junction box cover when the cover is removed.
 - (E) The junction box cover should be as close-fitting as possible and flushed with the floor surfaces. The cover should be sufficiently robust to resist damage by floor cleaning equipment.
 - (F) For carpeted floors, appropriate slits should be made on the carpet at all junction boxes to enable access to the floor ducts.
 - (G) All junction boxes should be readily accessible at all times.
 - (H) A nylon draw rope should be provided in the duct or conduit between every two adjacent junction boxes.
- (iv) Within each residential unit –

- (A) Conduit laid inside the housing unit should have a maximum of two 'L' bends between two outlets. These bends must be smooth and gradual. Prefabricated gradual bends are preferred.
- (B) Conduits should preferably be of at least 25mm in diameter.
- (C) The conduit should be free from internal roughness, sharp edges, moisture and dirt.
- (D) The conduit should be as straight as possible and should be rigidly mounted.

(v) Responsibility of developer or owner –

The developer or owner should be responsible for opening the junction box cover, when required by telecommunication system licensees to provide telecommunication service.

(vi) The advantages of an under-floor system are as follows –

- (A) Cables are well protected in the duct and conduits, therefore interruption of services caused by physical damage to cables is minimised;
- (B) Appearance of the premises is enhanced as the ducts or conduits are concealed in the floor slab; and
- (C) Safe and easy working position.

(vii) The disadvantages of an under-floor distribution system are as follows –

- (A) Junction boxes must be made accessible even when covered with carpet; and
- (B) Water can seep through the junction boxes and damage the cables.

(b) Perimeter raceway distribution system

Perimeter raceways that are suitable for use in residential buildings to distribute cables are similar to those used in commercial buildings. For details on the system, please refer to paragraph 5.2 (e).

(c) Ceiling distribution system

(i) General –

- (A) Cable trays or conduits are used to distribute telecommunication cables along common corridors in residential building.
- (B) From the cable tray or conduit along common corridors, the cables leading to an individual residential unit and within the unit can be routed using conduits installed above false ceiling and brought down to socket point through conduit in the wall.

(ii) Basic requirements –

- (A) Where cable trays/trunking/conduits are concealed in false ceilings, access panels should be provided for easy and unrestricted access to cable trays/trunking/conduits.
 - (B) The dimension of the access panels should not be less than 600mm x 600mm, and they should be provided at regular intervals of 6m as well as at positions where there is a change in the direction of the cable trays/trunking/conduits.
 - (C) All cable trays should be aligned and securely mounted.
 - (D) Cable trays should not be routed through toilets, high-tension (HT) switch rooms, and other inaccessible areas.
 - (E) "L" brackets for supporting cable trays should be installed in the same direction.
 - (F) No bolts, screws or sharp objects should protrude through the cable bearing surface of the trays.
 - (G) Where cable trays run alongside or across electrical cables, segregation according to the specifications stipulated in chapter 2, paragraph 2.2 of these Guidelines should be complied with.
 - (H) The maximum height of cable trays for horizontal cabling should not exceed 4m from the floor level.
 - (I) There should be a minimum clearance of 50mm between the cable tray and any obstruction above it. The space between the tray and false ceiling should be between 75mm and 150mm (Figure 5.18).
- (iii) Where conduits are used within each residential unit to distribute telecommunication cables above a false ceiling, the following requirements should be met:
- (A) Each conduit can have a maximum of two "L" bends. The bends should be smooth and gradual. Prefabricated gradual bends should be preferred. The distance between any two bends should preferably not exceed 2m;
 - (B) Where many bends are required, junction boxes should be provided at these bends to permit cabling works. An access panel or removable ceiling board should be provided at every junction box location;
 - (C) Conduits should preferably be at least 25mm in diameter.
 - (D) The conduit should be free of internal roughness, sharp edges, moisture and dirt;
 - (E) The conduit should be as straight as possible and should be rigidly mounted;
 - (F) Conduits within each residential unit should be used to lead the cable from false ceiling to each telecommunication outlet on the wall (Figure 5.31);

(G) The telecommunication outlets within each residential unit should be located at least 300mm above floor level;

(iv) Responsibility of developer or owner: -

The developer or owner should be responsible for removing and replacing ceiling boards to enable the telecommunication system licensees to have access to the cables above the false ceiling.

(v) The advantages of a ceiling distribution system are as follows: -

(A) It provides a flexible means of distributing telecommunication cables to specific locations.

(B) The possibility of physical damage to cables is minimised as the cables are protected.

(vi) The disadvantages of ceiling distribution system are as follows: -

(A) Telecommunication cables may be damaged when other work is being done in the ceiling area;

(B) Ceiling boards should be made removable, and there is a high possibility of them being damaged or tainted due to frequent removal and replacement; and

(C) Dirt and debris may be deposited on surrounding furniture when ceiling boards are removed and replaced.

(d) **Multi-riser system**

(i) General –

(A) Instead of providing one telecommunication riser in a multi-storey residential building to serve all the units on the same floor, a multi-riser system with one telecommunication riser serving one or more units per floor can be used (Figure 5.32).

(B) The telecommunication riser should have outlets at every housing unit. Wherever possible, the outlets should be located at the anticipated telecommunication locations to eliminate the cost of providing additional distribution systems from the outlet(s) to the telecommunication locations.

[FIGURE 5-1 DELETED]
[PAGE INTENTIONALLY LEFT BLANK]

FIGURE 5-2 : UNDERFLOOR DUCT DISTRIBUTION SYSTEM

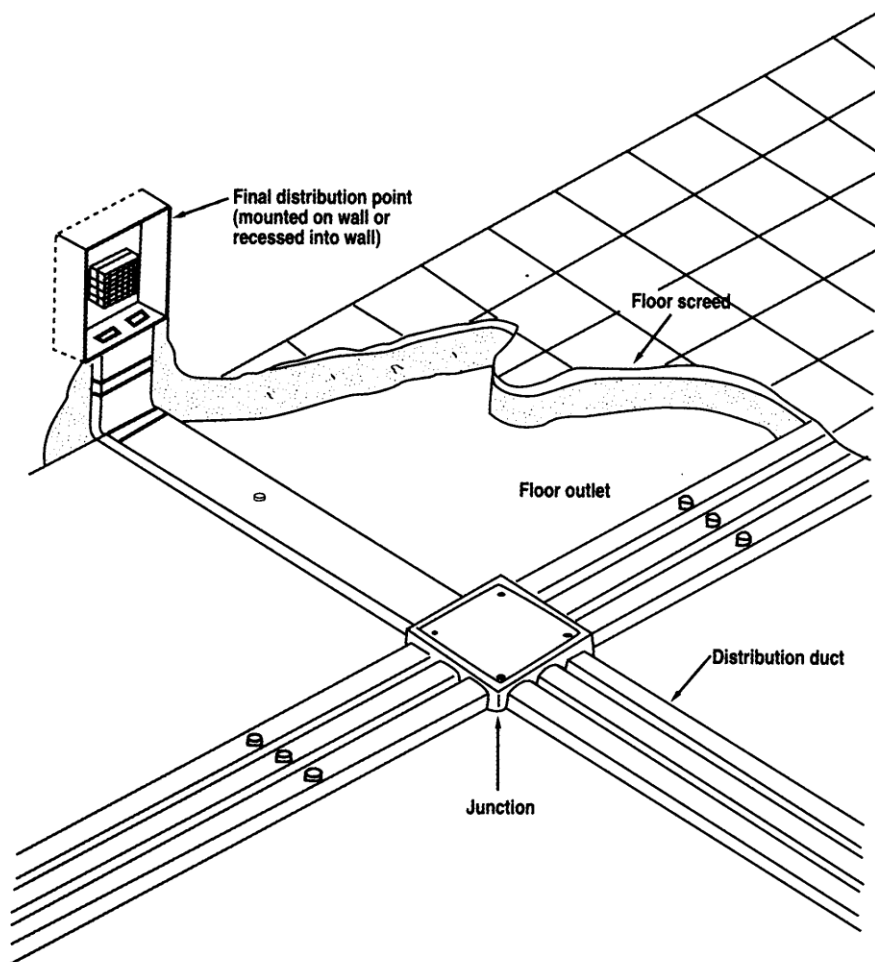

FIGURE 5-3 : TRENCH DUCT SYSTEM

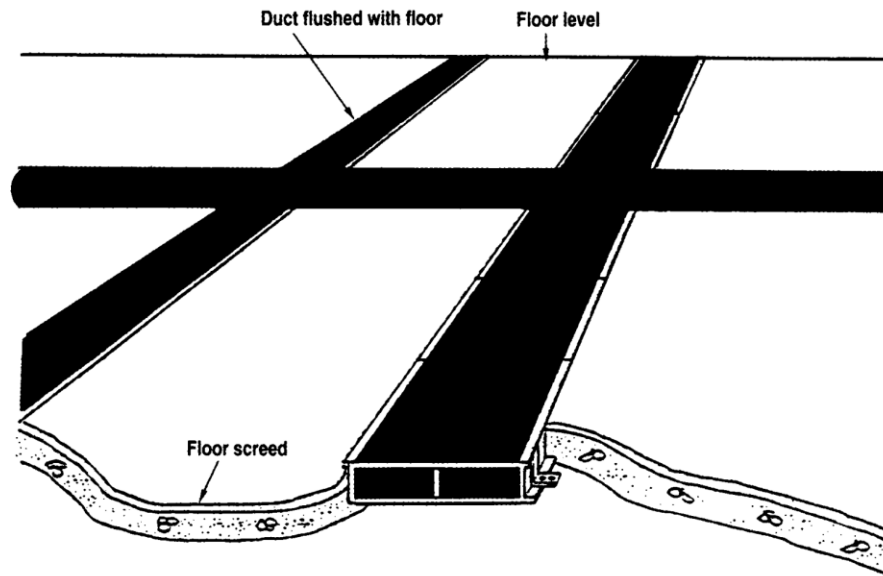

FIGURE 5-4 : UNDERFLOOR DUCT EXTENDED TO FLOOR TRENCH / FLUSH TRUNKING

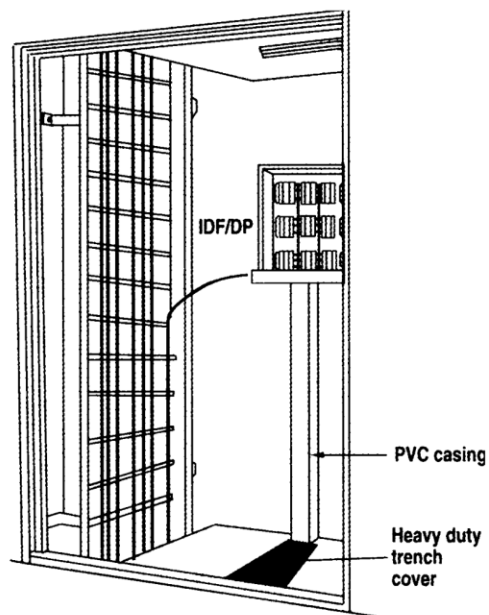

FIGURE 5-5 : FLOOR TRENCH IN CENTRE OR RISER

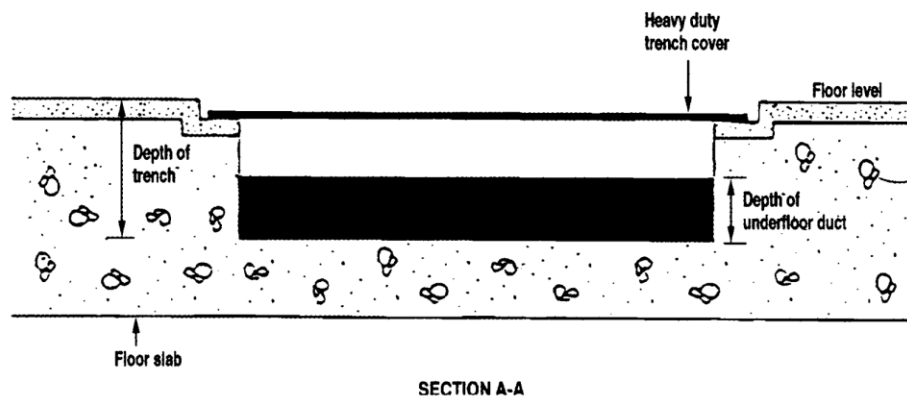
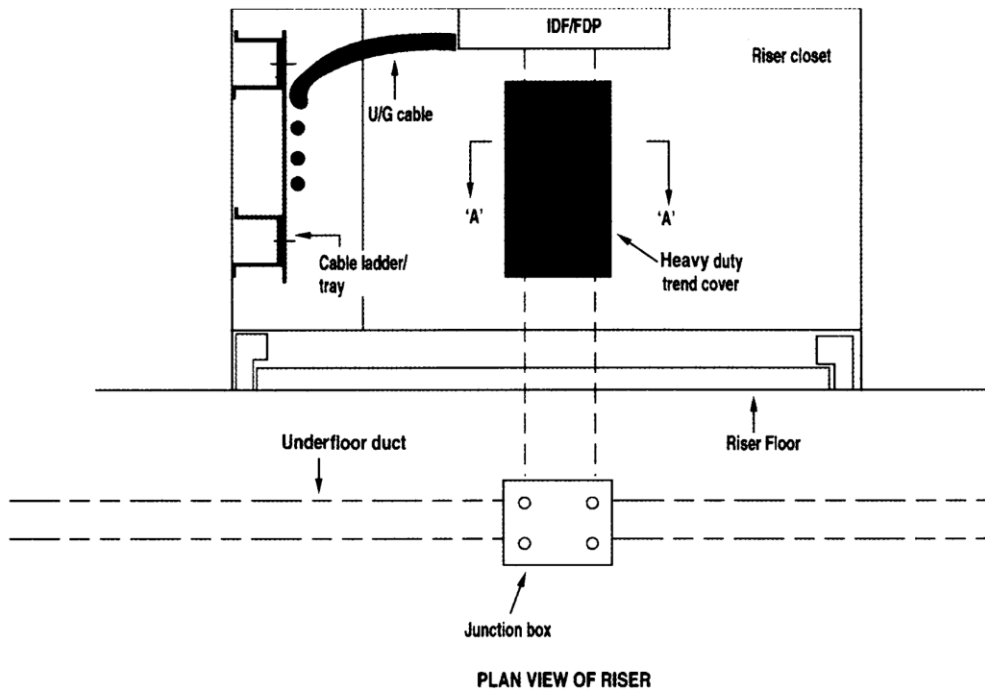
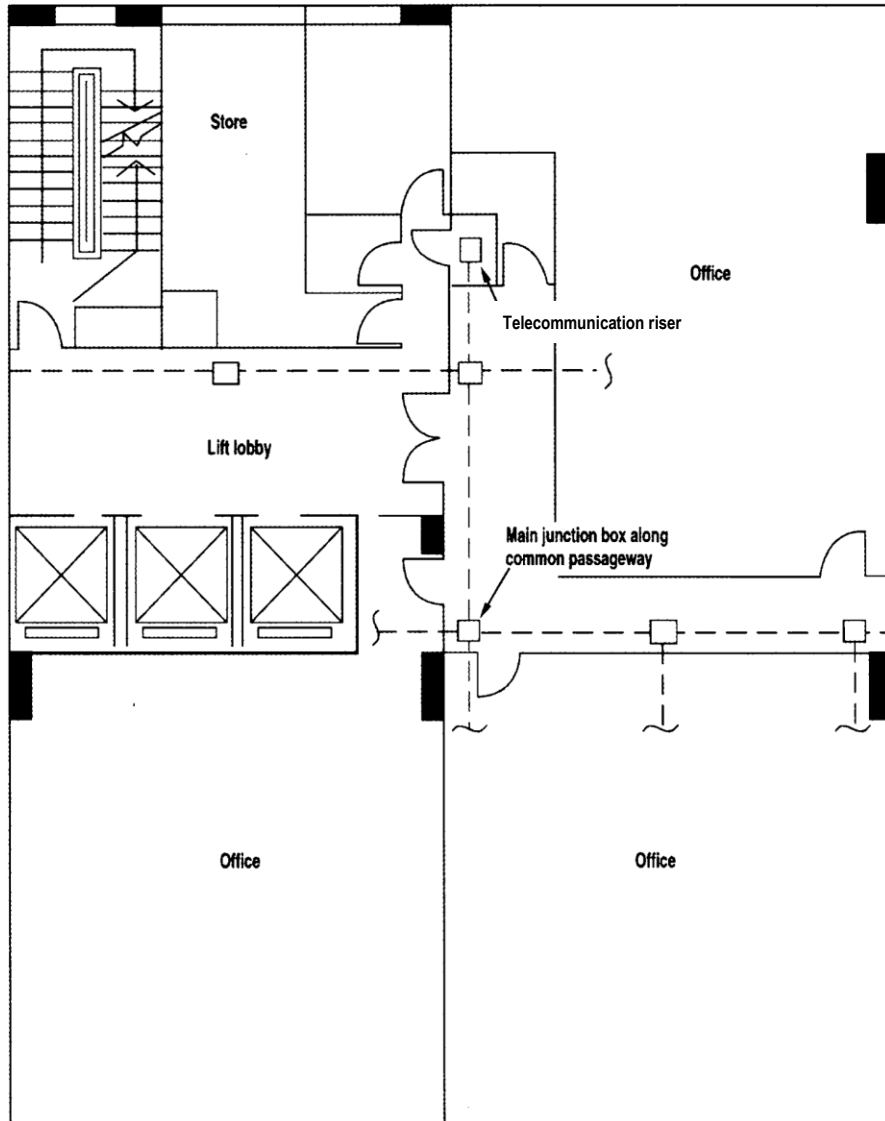

FIGURE 5-6 : MAIN JUNCTION BOXES ALONG COMMON CORRIDOR AREA OR PASSAGEWAY



LEGEND:

□ Main junction box

- - - - Underfloor duct or trunking

FIGURE 5-7 : TYPES OF DISTRIBUTION DUCTS AND OUTLETS

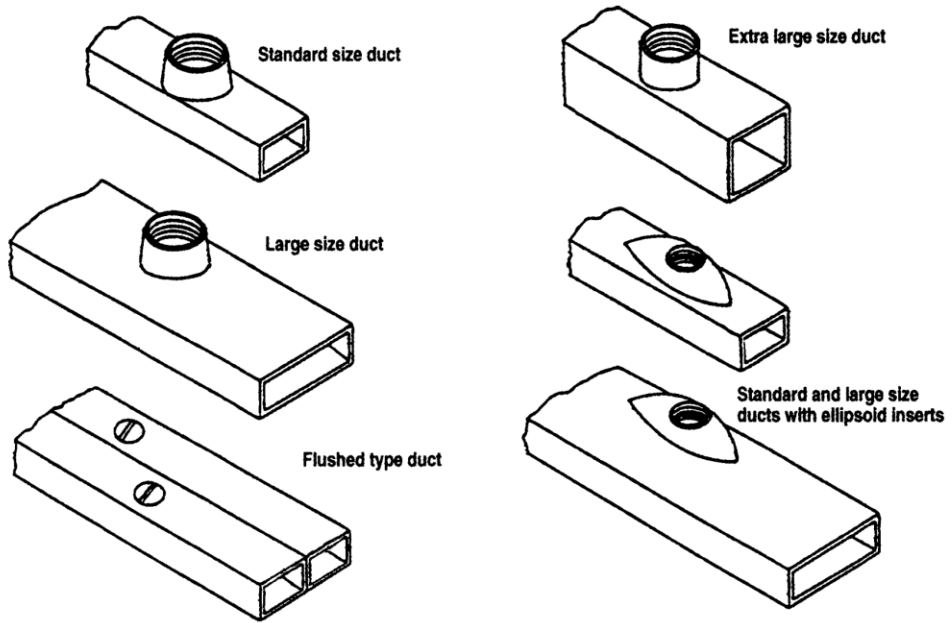

FIGURE 5-8 : JUNCTION BOXES INSTALLED 6 METRES APART

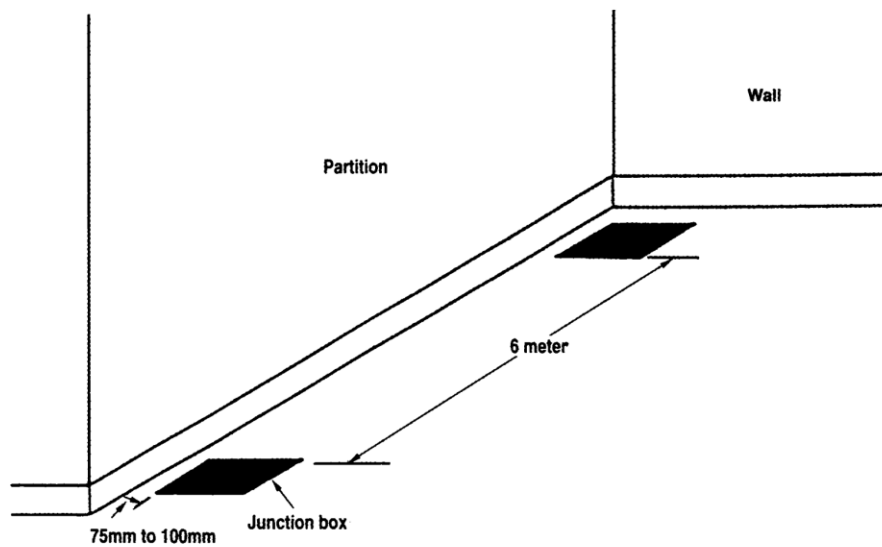

FIGURE 5-9 : EXPLODED VIEW OF JUNCTION BOX

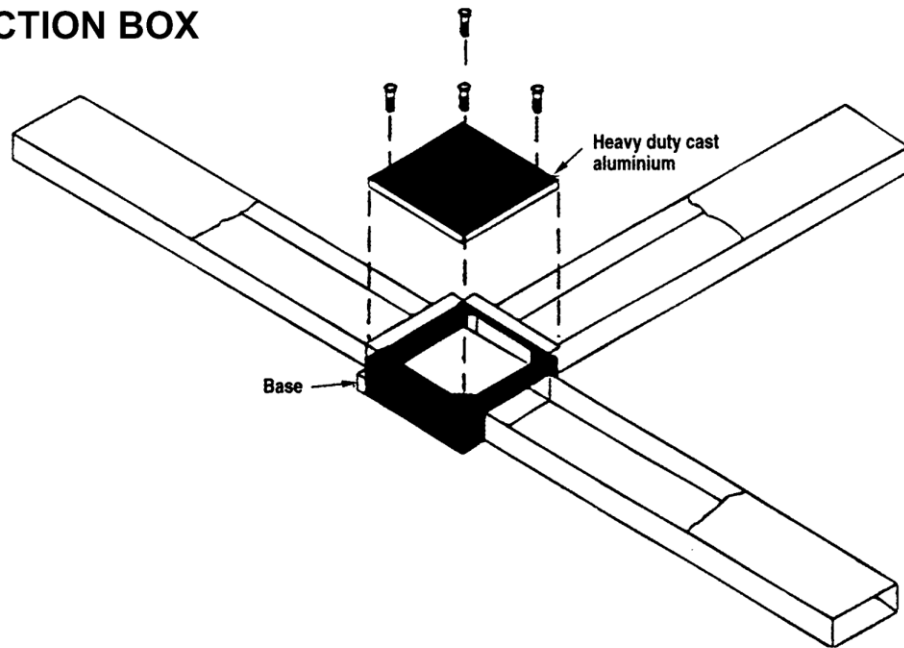

FIGURE 5-10 : PARTITION SITTING ON JUNCTION BOX

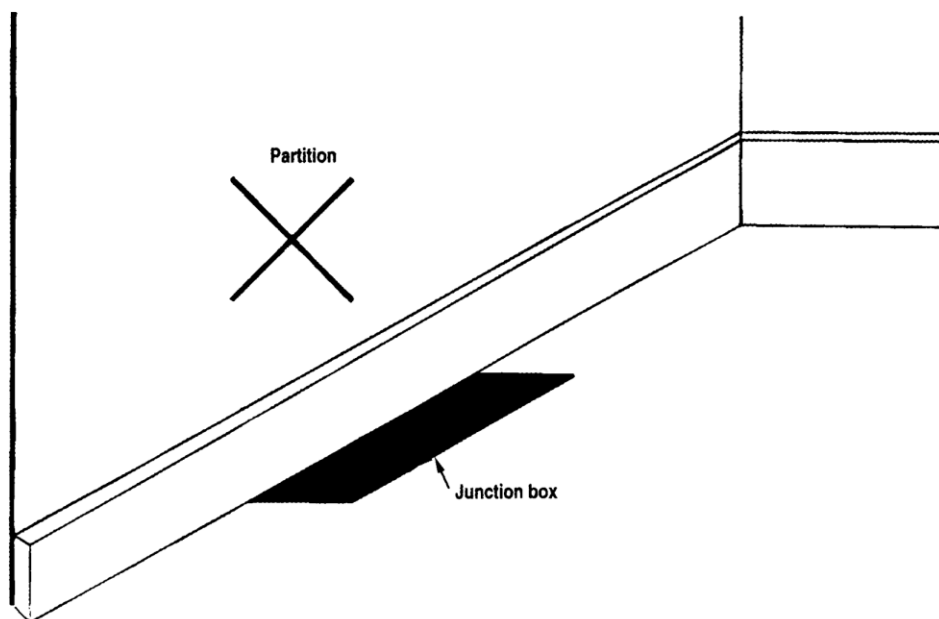

FIGURE 5-11 : ACCESS TO JUNCTION BOX FOR CARPETTED FLOOR

NOTES:

- 1) Carpet is cut on 3 sides of the junction box creating a flap 50mm wider than the junction box.
- 2) Nylon tape fasteners are glued to the carpet and floor both on the flap and the surrounding carpet edge to provide a neat, safe carpet access panel.

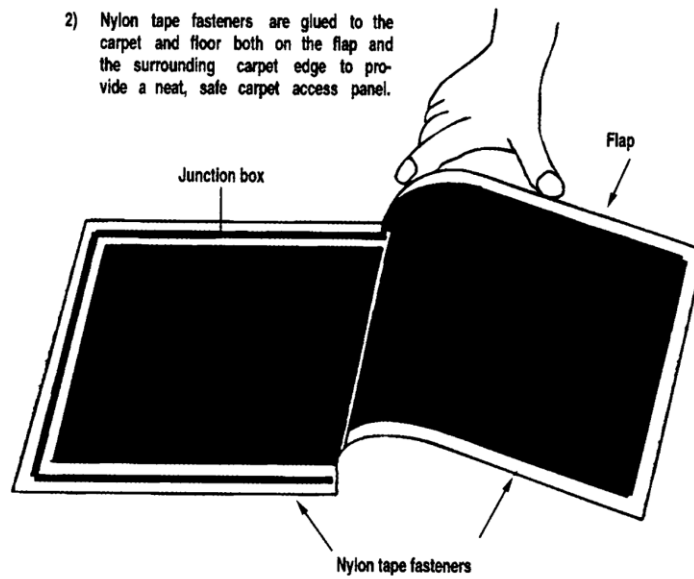

FIGURE 5-12 : RAISED FLOOR SYSTEM

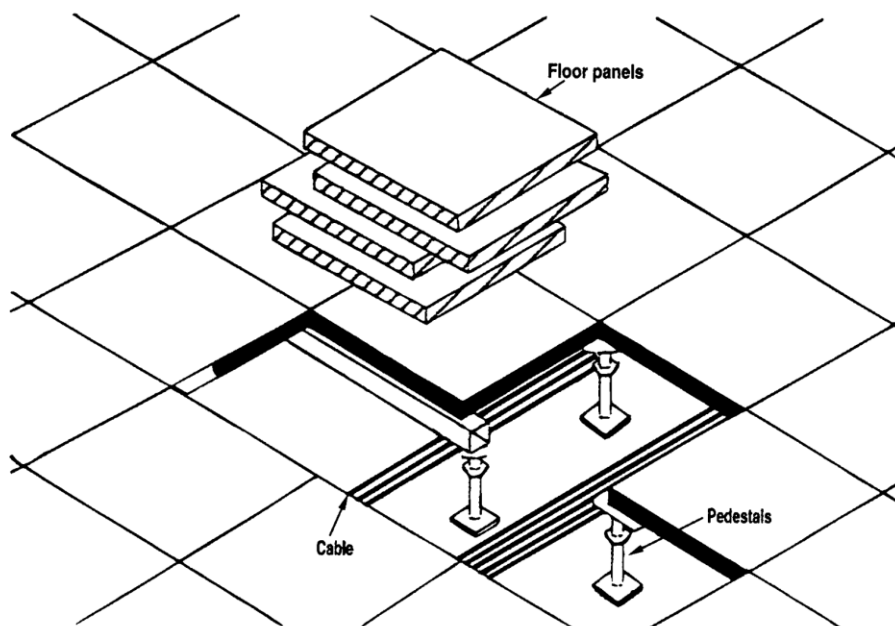

FIGURE 5-13 : PEDESTALS

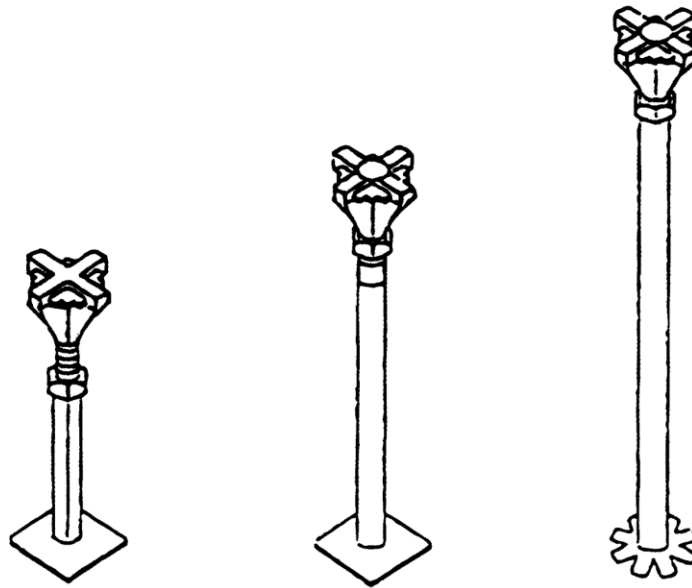

FIGURE 5-14 : TYPICAL SECTION OF RAISED FLOOR SYSTEM

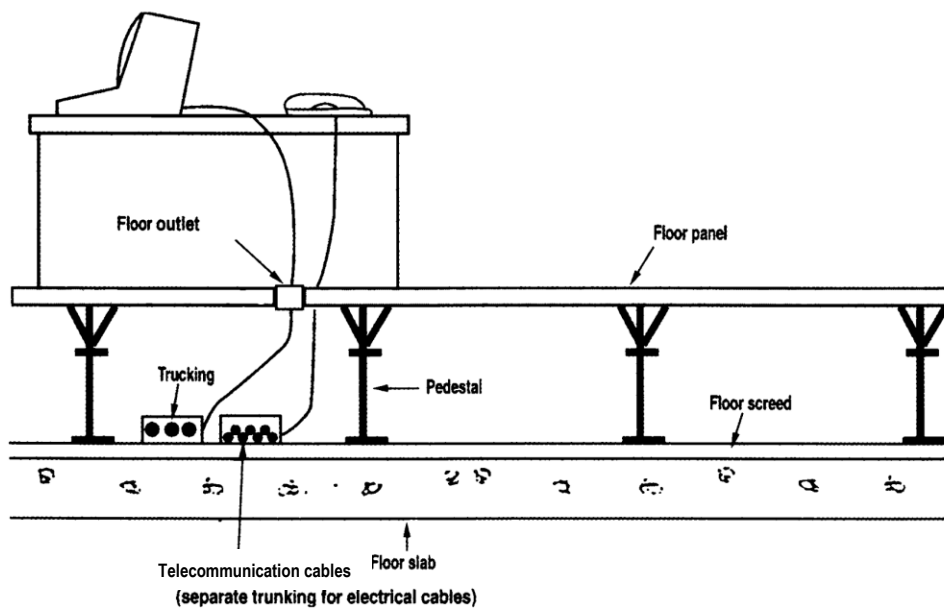

FIGURE 5-15 : SECTIONAL VIEW OF A CELLULAR FLOOR SYSTEM

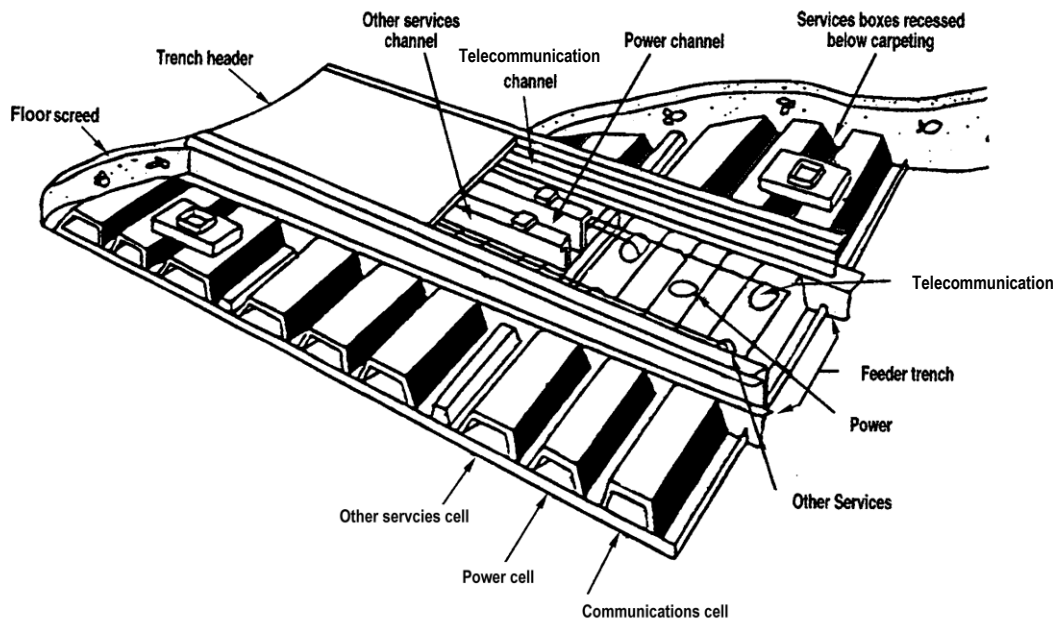

FIGURE 5-16: CEILING DISTRIBUTION SYSTEM USING CABLE TRAY/ TRUNKING LINK WITH CONDUITS & UTILITY POLE

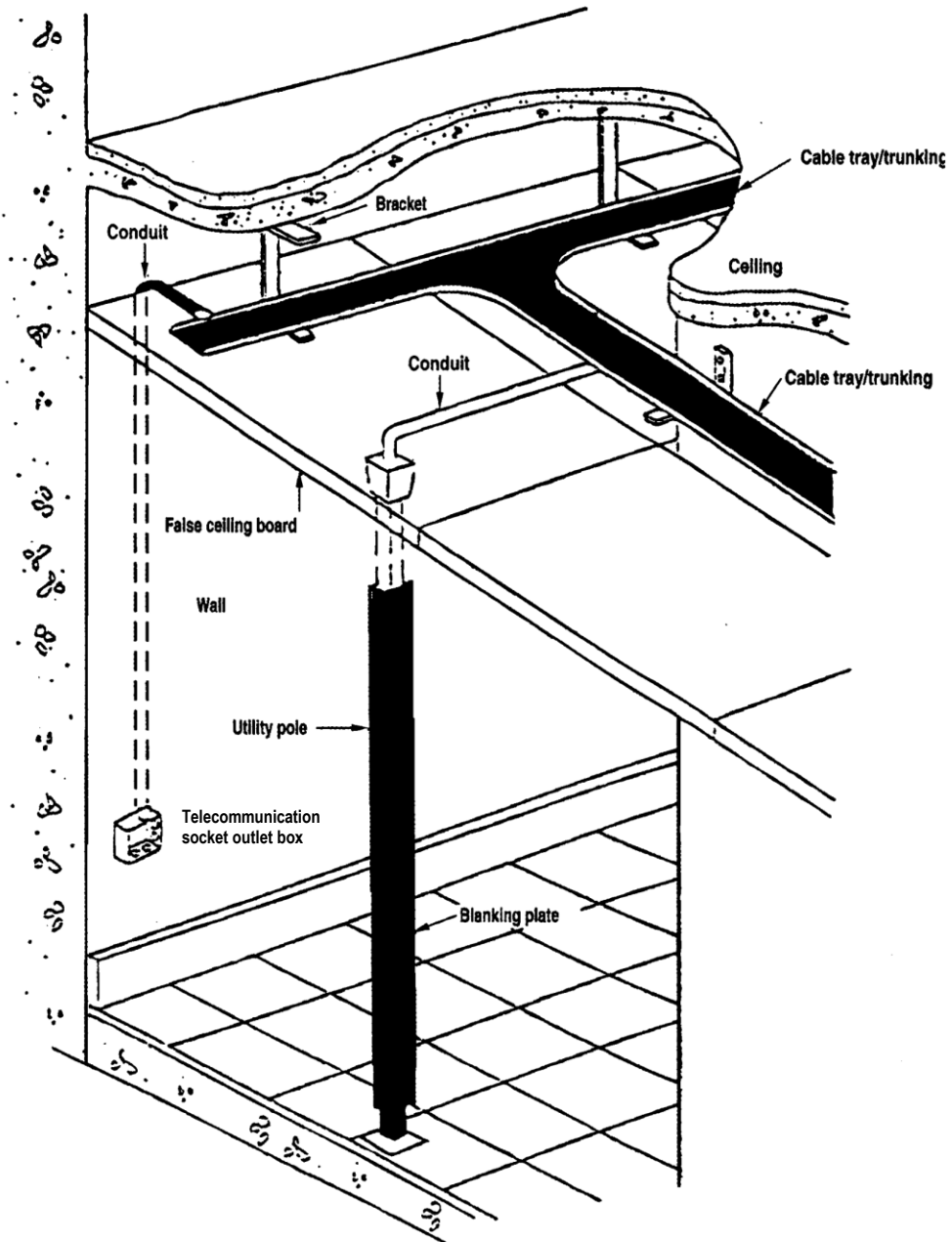

FIGURE 5-17: CEILING DISTRIBUTION SYSTEM – TYPICAL DETAIL OF CABLE TRAY/TRUNKING LINK WITH CONDUIT IN UNDETACHABLE FALSE CEILING BOARDS/STRIPS THAT ARE NOT EASILY REMOVABLE

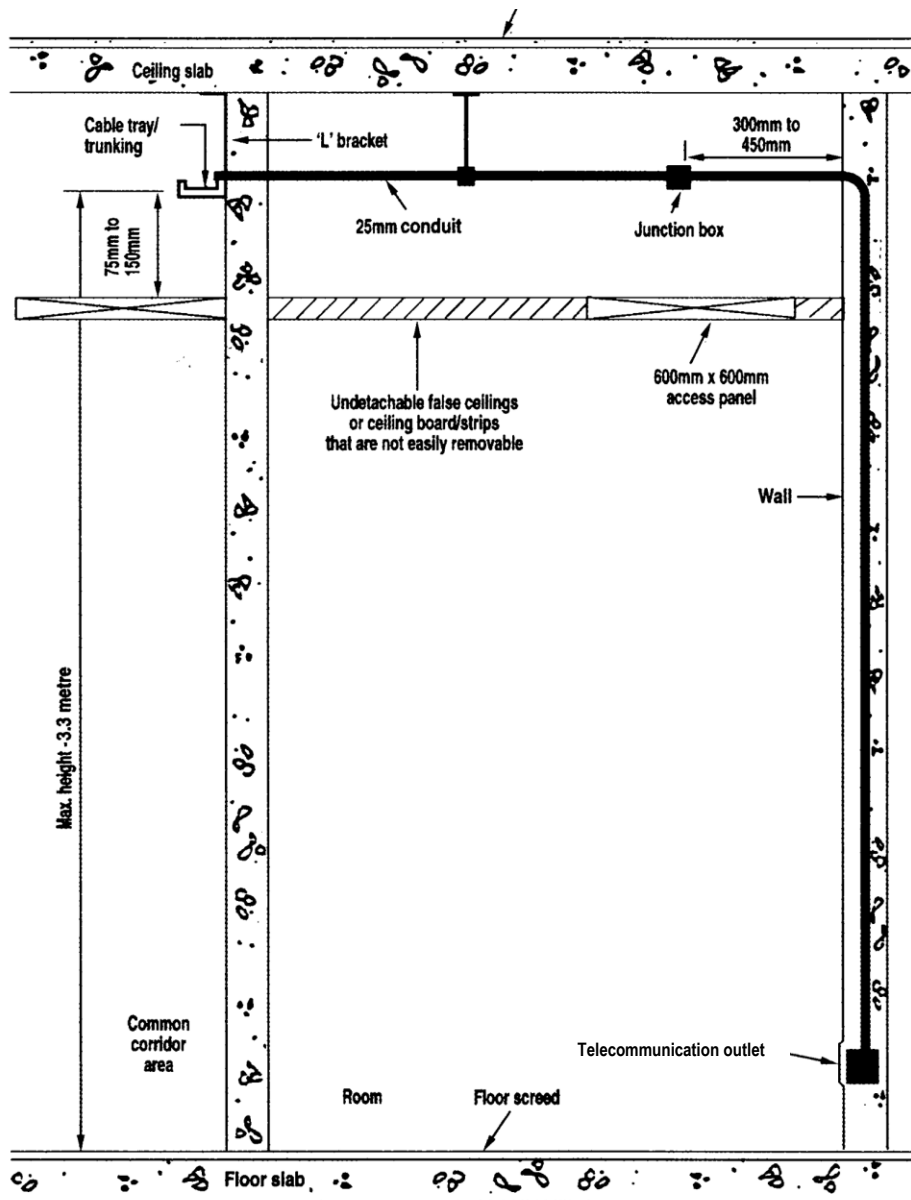
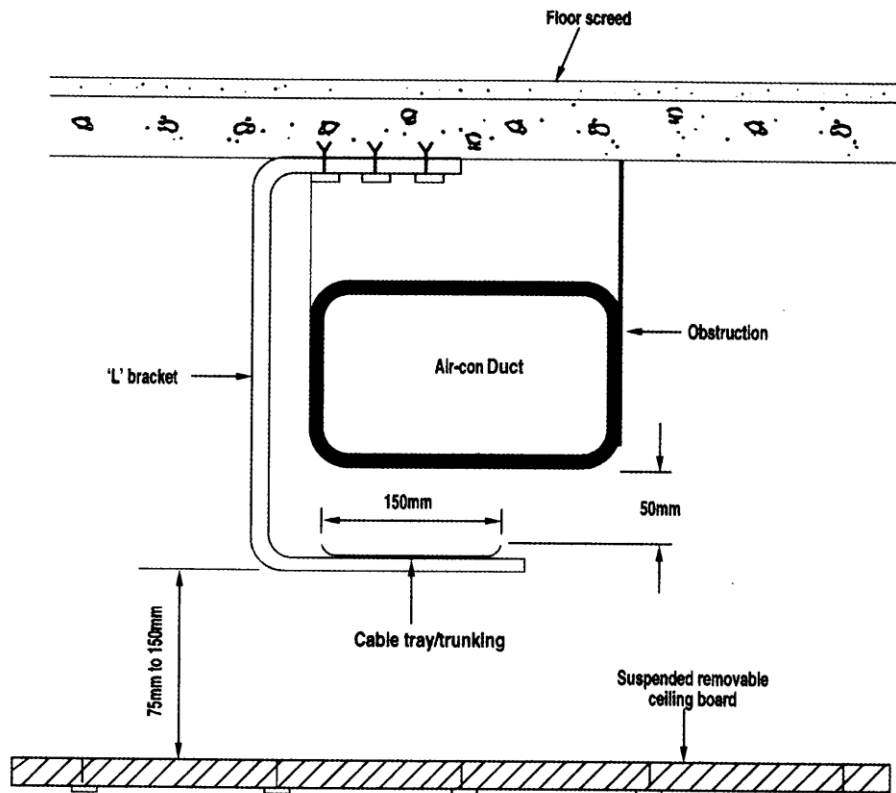

FIGURE 5-18: CLEARANCE BETWEEN CABLE TRAY/ TRUNKING AND OBSTRUCTIONS



Width of Cable tray/trunking	Minimum clearance between cable tray & obstruction
150mm	50mm
300mm	75mm
450mm	100mm
1000mm	150mm

FIGURE 5-19 : PERIMETER RACEWAYS MOUNTED AT TABLE HEIGHT LEVEL

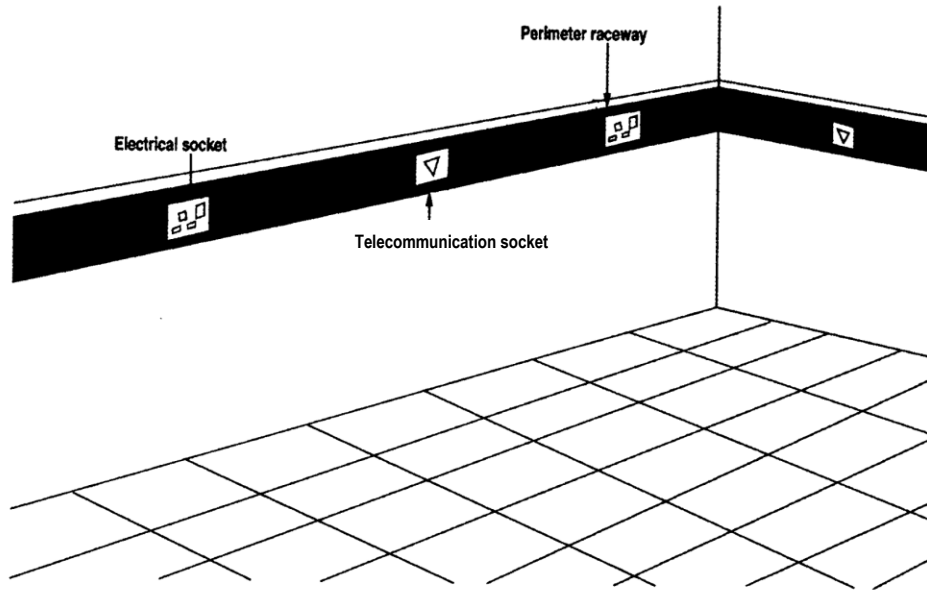

FIGURE 5-20 : PERIMETER RACEWAYS MOUNTED AT FLOOR LEVEL

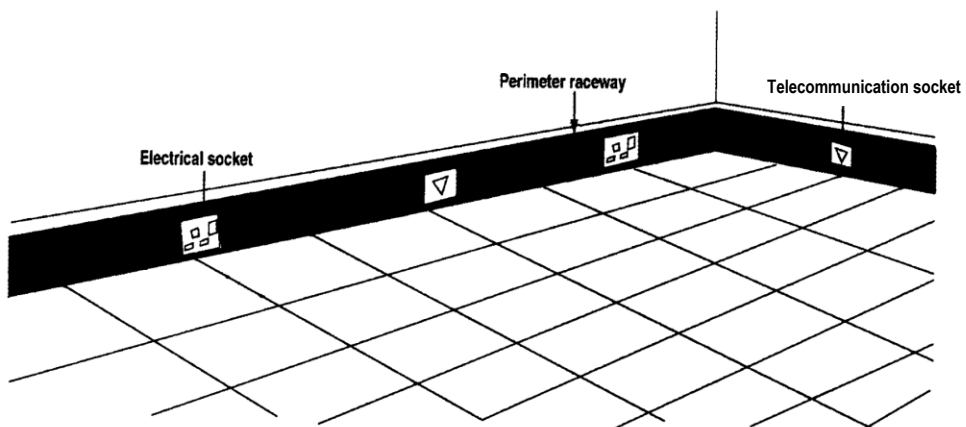

FIGURE 5-21 : PERIMETER RACEWAYS RECESSED INTO BASE OF WALL

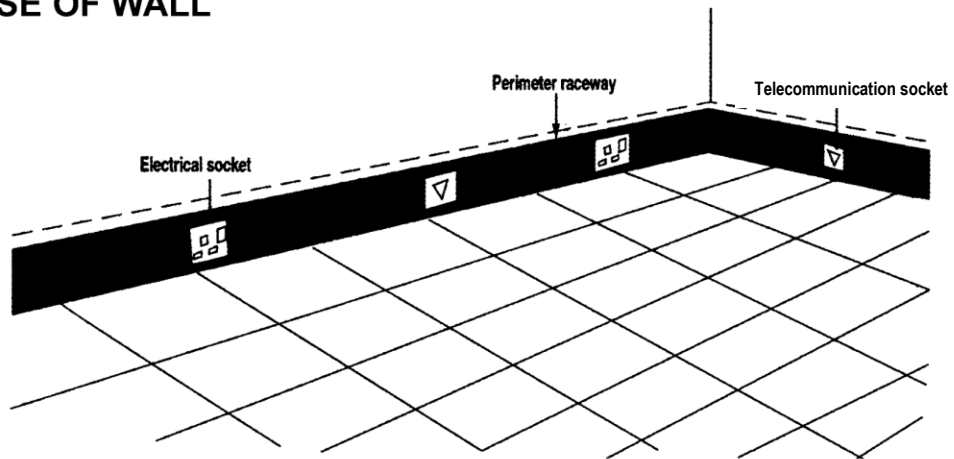

FIGURE 5-22 : SECTION OF A THREE - COMPARTMENT SKIRTING TRUNKING

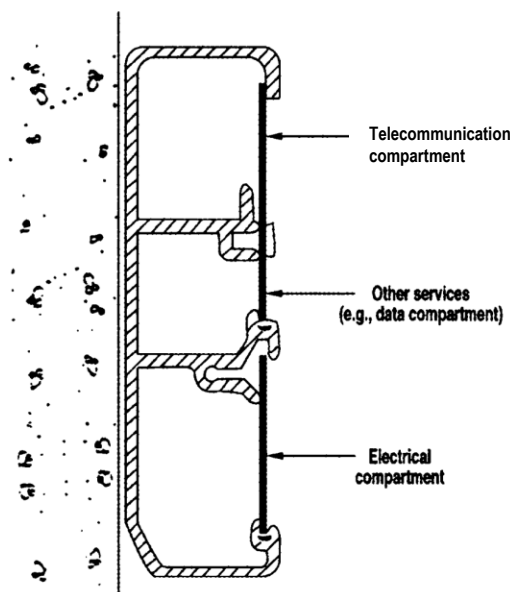

FIGURE 5-23 : PERIMETER RACEWAYS LINKED TO UNDERFLOOR DUCT DISTRIBUTION SYSTEM

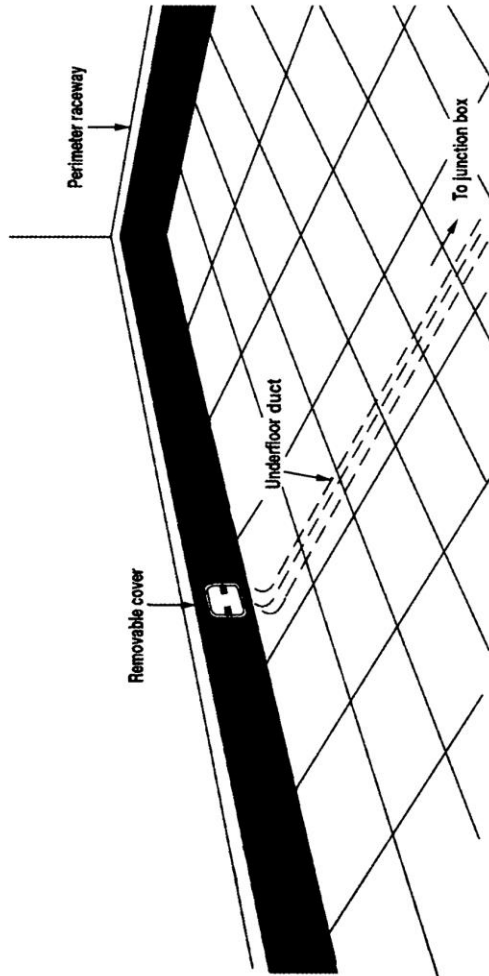

FIGURE 5-24 : POKE - THROUGH SYSTEM WITH CONDUIT

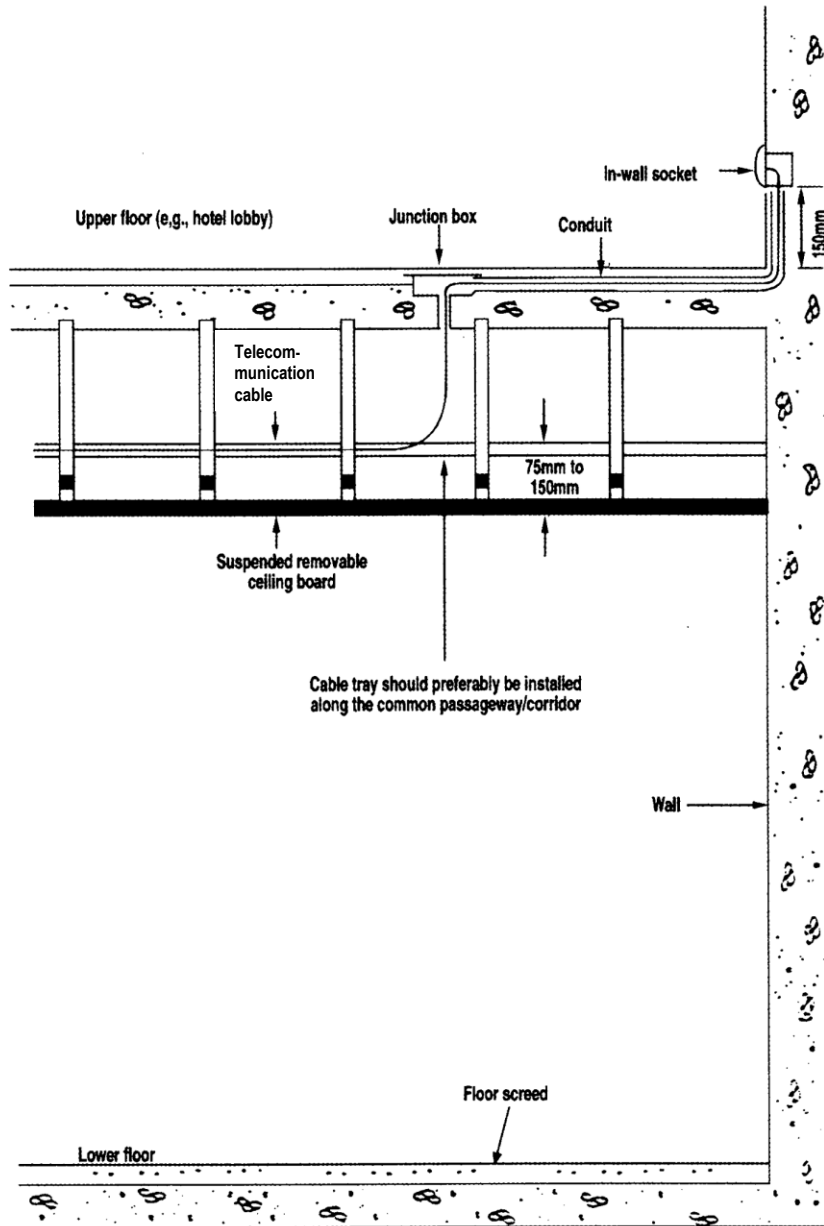

FIGURE 5-25 : CONDUIT DISTRIBUTION SYSTEM IN CERTAIN AREAS OF A HOSPITAL

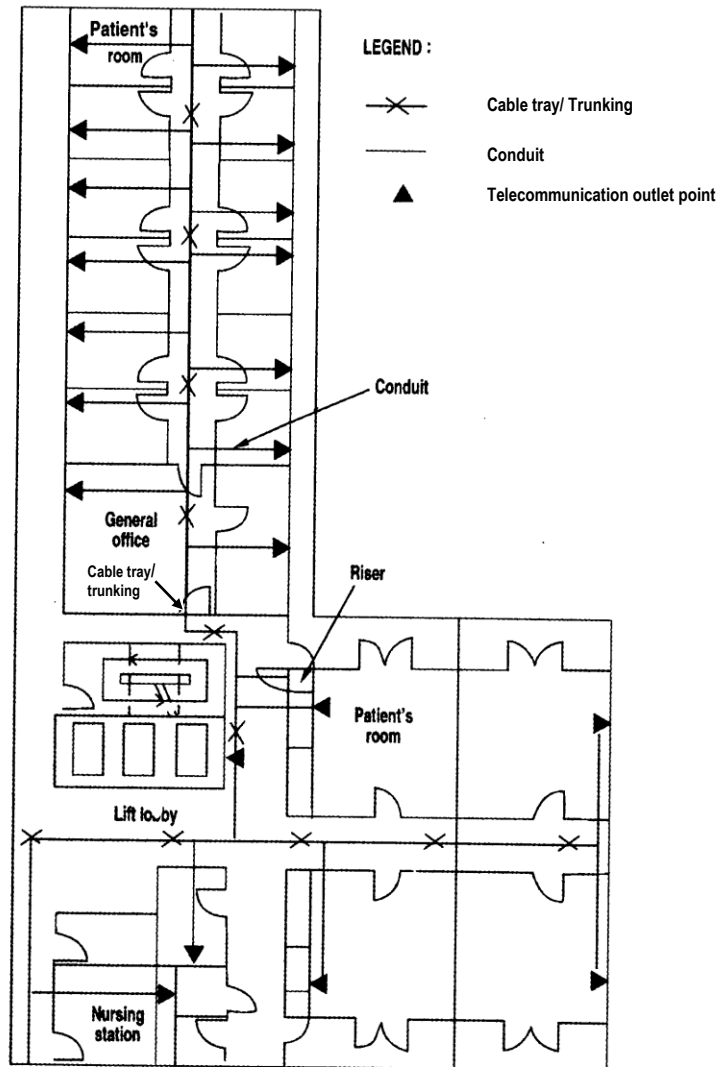

FIGURE 5-26 : CABLE TRAY BENDS & FITTING WITH 600MM MINIMUM RADIUS

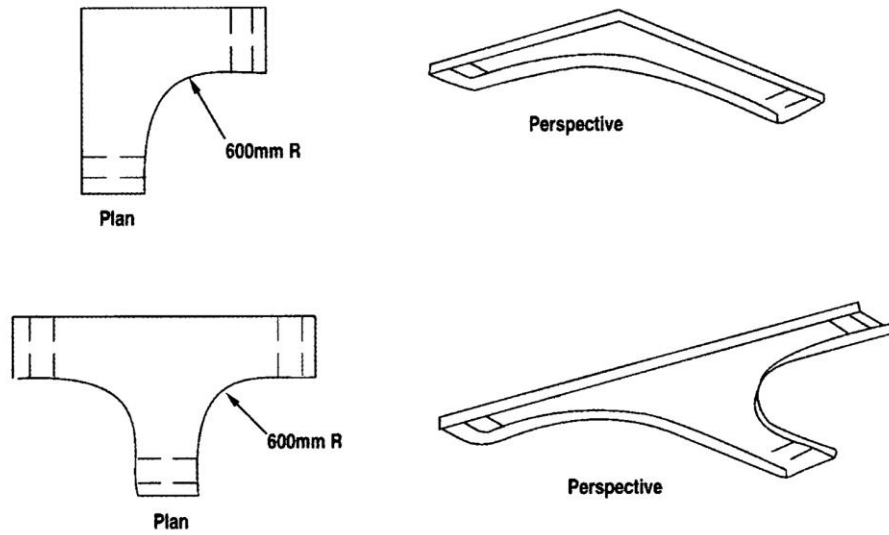

FIGURE 5-27 : TYPICAL EXAMPLE OF A TRUNKING SYSTEM

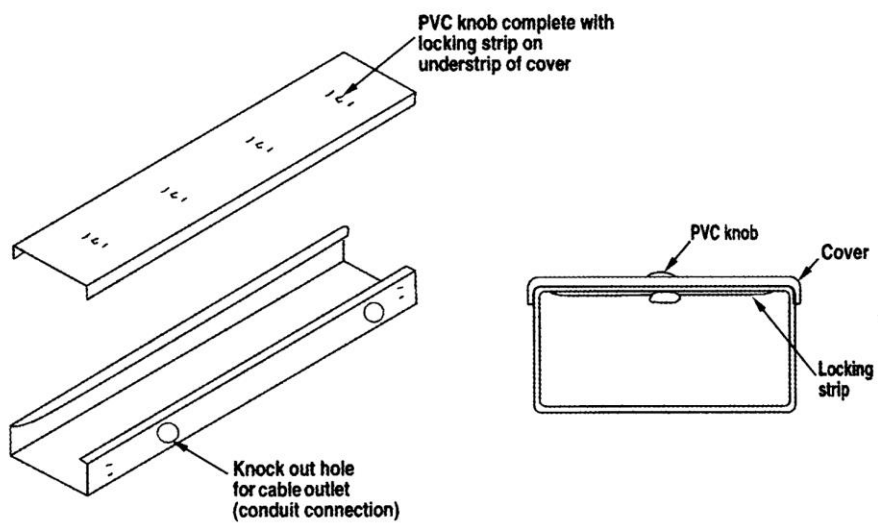

FIGURE 5-28 : COMBINATON OF DUCT & CONDUIT DISTRIBUTION SYSTEM

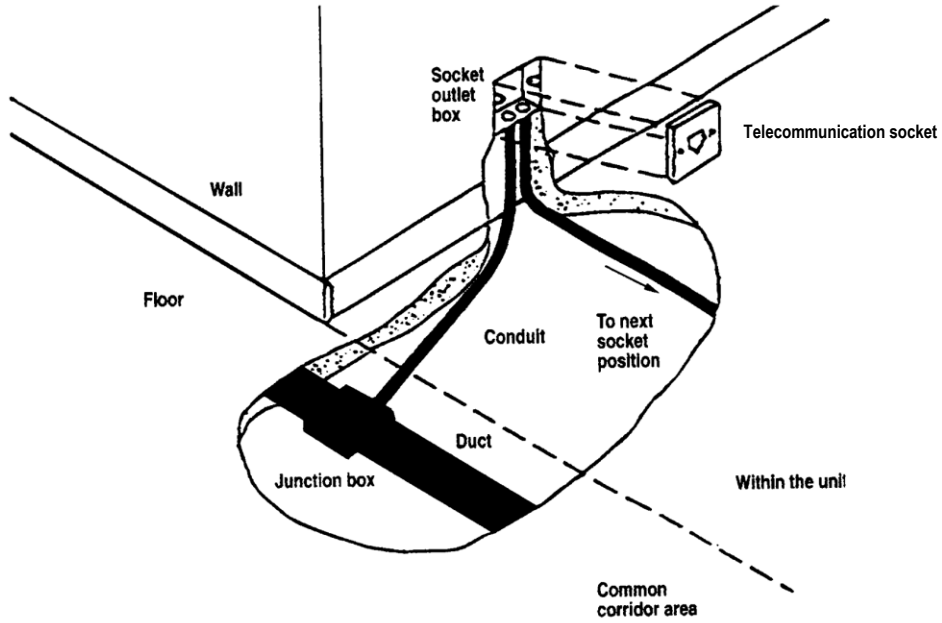

FIGURE 5-29 : USING CONDUITS TO DISTRIBUTION CABLES

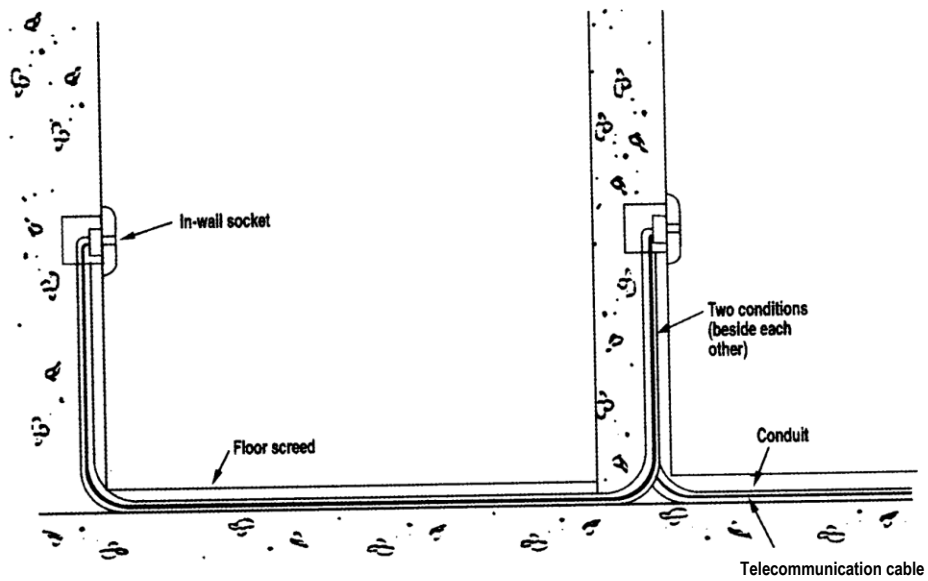

FIGURE 5-30 : FLOOR DUCT EXTENDED INTO TELECOMMUNICATION RISER

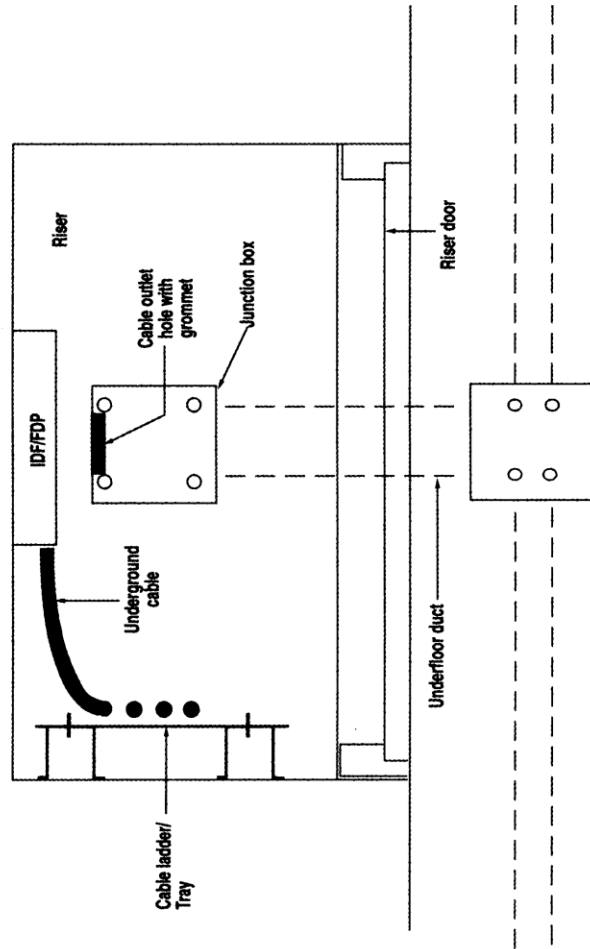

FIGURE 5-31 : CONDUIT IN FALSE CEILING & WALL TO DISTRIBUTION CABLES

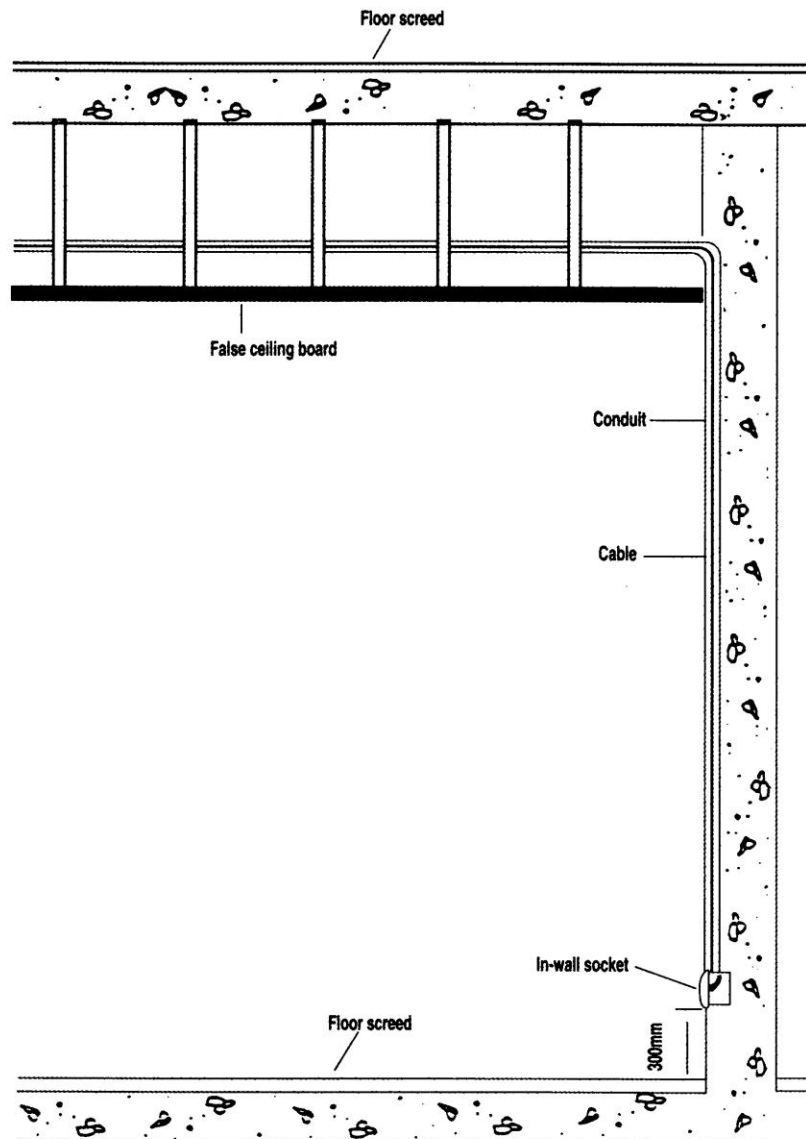
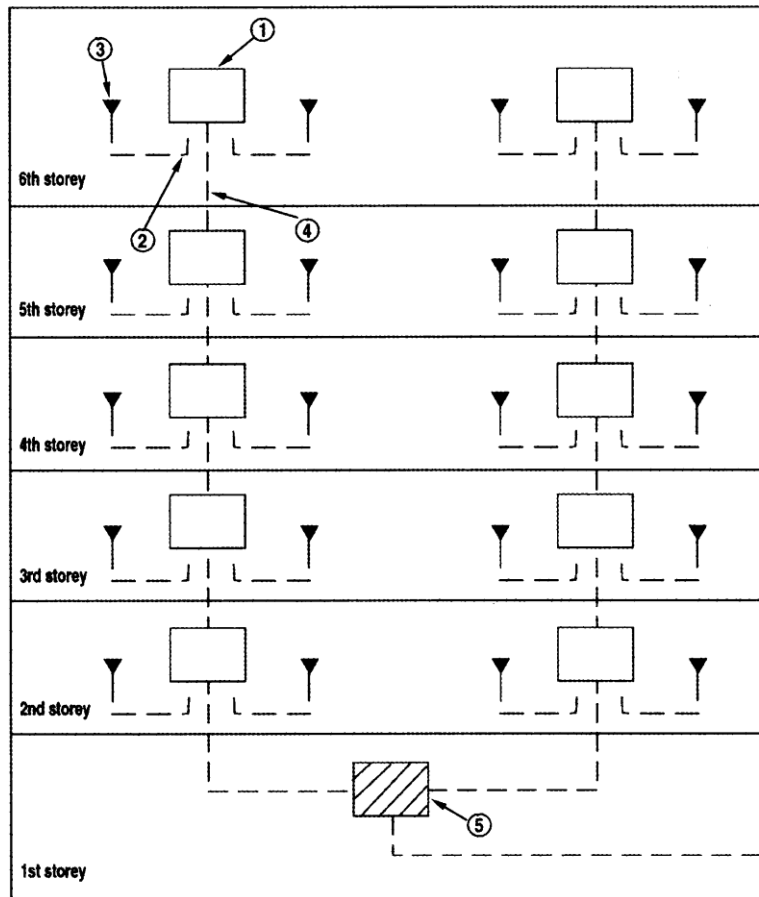

FIGURE 5-32: MULTI-RISER DISTRIBUTION IN A RESIDENTIAL BUILDING



LEGEND:

- ① Distribution point
- ② Horizontal cabling facilities (i.e., ducts, conduits or trunking)
- ③ Telecommunication riser
- ④ Cable riser (ducts and conduits)
- ⑤ MDF room

6 USER PREMISES CABLING AND INTERFACE POINT

6.1 Interface point for user premises cabling

(a) Internal telecommunication wiring

- (i) Internal telecommunication wiring (“IW”) means any telecommunication line, wire, cable, optical fibre, conduit or other physical medium connecting a user’s telecommunication equipment and any interface point (“IP”) but does not include the use of extension cords with built-in connectors and sockets. IW at the user’s premises shall be supplied and installed by IMDA licensed installers and contractors.

- (ii) Under the IMDA Licensing Scheme for Telecommunication Wiring Contractors and Telecommunication Wiring Installers, all telecommunication wiring contractors and installers are required to comply with the Code of Practice for Internal Telecommunication Wiring.

Note: The Code of Practice for Internal Telecommunication Wiring is subject to revision from time to time to keep abreast of technical developments and technological advancement.

6.2 Record of cable distribution system and documentation of pre-cabling or internal telecommunication wiring work

- (a) The developer or owner shall keep an up-to-date set of the telecommunication cable distribution system drawings and a record of the pre-cabling or internal telecommunication wirings for reference purpose.

7 INSTALLATION/ UPGRADING OF THE ANTENNAE SYSTEM TO RECEIVE DIGITAL TERRESTRIAL TELEVISION AND FM RADIO

7.1 General

- 7.1.1 This chapter refers to the installation or upgrading of the common outdoor antennae system (i.e. on the rooftop or on the external wall of the MDF room) in private residential developments. The common outdoor antennae system is also described in this chapter as the TV/FM Distribution System (TFDS) for the reception of digital TV broadcast programmes (DVB-T2)/FM radio.
- 7.1.2 The installation of or upgrading of the common outdoor antennae system shall comply with the relevant authority's requirements (e.g. height restrictions).
- 7.1.3 The developer or owner may need to install additional passive and active devices such as filters, decoders, reverse signal path amplifiers, interdiction equipment etc., in order to keep abreast with technological changes and new technical requirements.
- 7.1.4 The developer or owner should ensure that the carrier/signal levels of the local TV and FM outlets follow the requirements set out in paragraph 7.3.2.

7.2 Performance requirements for the TFDS

7.2.1 Objective

The objective of the requirements included in this chapter is to ensure that the system performance limits are well optimised for the receiving of the upstream signal (over the air), the conversion of the upstream signal into a downstream signal and the transmission of the downstream signals.

7.2.2 The TFDS should minimally have the following functionality:

- (a) Antennae (on rooftop or external wall of MDF room) to receive DVB-T2 and FM radio signals;
- (b) Able to receive DVB-T2 signals off the air and convert the signals into suitable form for downstream distribution (i.e. to the units in the development);
- (c) Able to amplify the signal; and
- (d) Capable to provide power to the antennae.

7.3 General Requirements

All requirements refer to the performance limits that shall be obtained between the input to the head end(s) and any system outlet when terminated in a resistance equal to the nominal load impedance of the system, unless otherwise specified.

7.3.1 Impedance

The nominal impedance of the system shall be 75Ω . It should be noted that this value applies to all coaxial feeder cables and system outlets and should be used as the reference impedance in level measurements.

7.3.2 Carrier/signal levels at system outlets

(a) Minimum and maximum carrier/signal levels

The minimum and maximum carrier/signal levels at system outlets are shown in Table 7.3.2.

Table 7.3.2 Carrier/signal levels at system outlets

Signal type	Frequency	Minimum Level (dB μ V)	Maximum Level (dB μ V)
Digital Terrestrial Television	534 - 614 MHz	50	70
FM Radio	88-108 MHz	57	74

(b) Carrier/ signal levels

The maximum and minimum signal levels specified in Table 7.3.2 are applicable to all TV and FM outlets on the antennae system. In addition, the terrestrial digital TV signals at all outlet plates should have a carrier-to-noise ratio of 26 dB or above.

7.4 Network topology

7.4.1 The network input port shall be designed for proper TV/FM Distribution System (TFDS) network operation with TV channel loading as follows:

- Channel loading - 10 DVB-T2 multiplexes (from Ch29 to Ch38) Between 50dBuV to 70dBuV

7.4.2 Wiring facilities for TFDS cables

Suitable cable routes, such as trunking, conduits, risers, etc. as well as means of mechanical protection shall be provided for the wiring of a complete TFDS. The cable routes shall have as few bends as practicable.

7.4.3 Routing to residential units

- (a) The passive device (Tap/Tee) feeding the system outlets in each residential unit shall be connected to a dedicated subscriber feeder cable from the nearest distribution panel/box.
- (b) Subscriber feeder cables shall be installed in conduits throughout their entire length so that they cannot be accessed by unauthorised person(s). Where multiple feeder cables are bunched together, cable trunking, with adequate covers may be used in lieu of conduits.
- (c) No splice or termination between the passive device and the system outlet shall be made in the subscriber feeder cable, except within the residential unit.

- (d) All subscriber feeder cables shall be properly labelled and clearly marked at the distribution panel. The labels or markings shall designate the particular unit address to which each subscriber feeder cable is connected.

7.4.4 Distribution panels and boxes

- (a) The distribution panels/ boxes shall be lockable and securely mounted to the building wall. The distribution panels/boxes need not be lockable if they are securely mounted on the side of the telecommunication riser facing the door.
- (b) All connectors shall be located within the distribution panels/boxes to ensure effective shielding against RF ingress and egress.
- (c) The lockable distribution panels/boxes shall be able to accommodate the required number of in-line negative traps, accessories and amplifiers.

7.5 Antennae installation

The recommended options which private residential building owners may adopt for the installation of antennae within their development are described in paragraphs 7.5.1 and 7.5.2. The installation of the antennae may be on either the building rooftop or the external wall of the MDF room.

7.5.1 Antennae installed on building rooftops

- (a) The antennae installed should be designed to withstand a wind velocity of 145km/h.
- (b) The antennae elements should be made of aluminium, with clamps of die-cast aluminium, zinc base alloy, anodised metal or ferrous material that is adequately protected against corrosion and has good electrical and mechanical properties. Clamp supports may also be made of ultra-violet stabilised plastic material.
- (c) The bolts, nuts, washers and screws that are used for securing the elements to the antennae boom should also be adequately protected against atmospheric and electrolytic corrosion. The characteristic impedance of the antennae should be 75Ω.
- (d) Stainless steel antennae should be used where heavy-duty performance is required.
- (e) Each part of the antenna and the mast should be adequately protected against the deterioration that may be caused by the worst weather conditions. Antennae should be installed on and cables should not pass through roofs with soft covering. Locations where atmosphere is explosive or flammable should be avoided.
- (f) The mast should be constructed of galvanised steel (preferably hot-dip galvanised), stainless steel or other material of adequate mechanical strength to withstand the bending movements caused by the combined wind loading and the weight of the antennae.
- (g) The top open end of the mast should be capped to prevent ingress of water.

- (h) The mast should be supported by at least three sets of stay (or guy) wires that are evenly spaced.
- (i) The mounting bracket of the mast should be galvanised, preferably by the hot-dip process and painted with zinc-enriched primer paint.
- (j) Dynabolts, rawbolts, clamps, u-clips, turnbuckles and sleeve anchors that are used to secure the mounting bracket and for anchoring the stay (or guy) wires should be corrosion resistant.
- (k) The stay (guy) wires should be of the electro-galvanised or stainless steel type.
- (l) The gap between the antennae mast and the mast holder of the bracket should be sealed with silicone rubber or other waterproofing sealant.
- (m) The protective coats that are damaged during installation must be painted with anti-rust paint or zinc-enriched primer paint if the galvanised part is affected.

7.5.2 Antennae installed on the external wall of the MDF room

- (a) The antenna installed on the external wall of the MDF room should blend in with the surroundings or be generally consistent with the overall aesthetic of the common area where the MDF room is located.
- (b) Where possible, the antennae installed on the external wall of the MDF room should be located where there is no obstruction or hindrance around it.
- (c) The antennae should be encased in a small box to prevent any vandalism to it. The small box should be made of fibreglass or plastic, so as not to affect the reception of the DTV signal, and may be painted to blend in with the surroundings.

7.6 Head End Equipment

- 7.6.1 The equipment shall be securely mounted and easily accessible for maintenance purposes.
- 7.6.2 All exterior housings shall be weatherproof, unless installed inside the MDF room.
- 7.6.3 The head end equipment, channelised amplifier or channel processor installed should be able to receive DVB-T2 signals for SDTV and HDTV and FM signals.

7.7 Cables

- 7.7.1 Coaxial cables shall be used for the installation of a TFDS. The cables shall meet or exceed the minimum requirements stated in this chapter.
- 7.7.2 User feeder (drop) cables (above ground) – RG6 coaxial cable

General requirements:

- (a) Characteristic impedance: $75\Omega \pm 2\Omega$;

- (b) Velocity of propagation: more than 85%;
- (c) Structural return loss: exceed 20dB (47-824 MHz);
- (d) The centre conductor shall be copper-clad steel, Beryllium copper alloy or hard drawn copper. It shall have a solid single core;
- (e) The dielectric shall be gas expanded foam polyethylene;
- (f) The shielding shall consist of an aluminium-polypropylene-aluminium (or equivalent) laminated tape longitudinally wrapped with an overlap around the dielectric and shall be bonded to the dielectric with a layer of adhesive to provide 100% coverage and long-term reliability of shielding performance;
- (g) The outer jacket shall be polyvinyl chloride (PVC) for dry environment and polyethylene (PE) for damp environment;
- (h) The screening effectiveness shall be either:
 - (i) greater than 90dB at 200MHz when measured using the Dipole Antennae Procedure (see NCTA Recommended Practices for Measurements on Cable TV Systems, 2nd Edition, Part 1, Section J), or
 - (ii) greater than 80dB at 200MHz when measured using the Absorbing Clamp method (see pr EN 50083-2:1992);
- (i) The cables used shall be able to withstand long term operation in high humidity environments without deterioration; and
- (j) Suitable centre conductor with corrosion prevention should preferably be incorporated to reduce corrosion or oxidation of the centre conductor's copper surface.

7.7.3 Main cables (aboveground)

General requirements:

- (a) All main cables shall be hard-line (solid outer conductor) cables;
- (b) The characteristic impedance shall be $75\Omega \pm 2\Omega$;
- (c) Velocity of propagation, more than 87%;
- (d) Structural return loss (measured with the cable under test terminated in its conjugate impedance) shall exceed 20dB at any frequency in the band 47-824 MHz;
- (e) The dielectric shall be gas expanded foam polyethylene or other dielectric of similar electrical properties. The cable with equivalent dielectric shall be in every respect no less effective than that with gas expanded foam polyethylene;
- (f) The dielectric shall be bonded to the outer conductor with an adhesive coating; and

- (g) For installations where cables must bend extensively or must bend at a radius of less than 10cm, only cables with outer jacket bonded to the outer conductor shall be used. Care must be taken not to bend the cables beyond their specified minimum bending radius. For such installations, .412 size cable with full bonding of jacket to outer conductor and outer conductor to dielectric is recommended.

7.7.4 Underground cables

Underground cable joints shall be avoided. Where it is necessary, suitable connectors shall be used and the joints shall be sealed with waterproofing compound.

The underground coaxial cables shall meet or exceed the requirements stated herein:

- (a) All underground main cables shall be hardline (solid outer conductor);
- (b) The characteristic impedance shall be $75\Omega \pm 2\Omega$;
- (c) Velocity of propagation, more than 87%;
- (d) Structural return loss (measured with the cable under test terminated in its conjugate impedance) shall exceed 30dB at any frequency in the band 47-824 MHz;
- (e) The dielectric shall be gas expanded foam polyethylene; and
- (f) The underground cables shall be waterproof and weather resistant.

7.8 Safety

7.8.1 Safety requirement

A cabled distribution system shall be so designed, constructed and installed as to present no danger, either in normal use or under fault conditions to subscribers, personnel working on or externally inspecting the system, or to any other person, providing particularly:

- (a) personal protection against electric shock;
- (b) personal protection against physical injury; and
- (c) protection against fire.

Note: The above does not apply to authorised personnel working on the apparatus, which may involve the exposure of live parts by the removal of protective covers.

7.8.2 Main-supplied apparatus

- (a) The devices used in a cabled distribution system shall meet the requirements of IEC 60065:2001 and the requirements of the Energy Market Authority ("EMA"). In addition, the specific requirements of the following sub-paragraphs (b) and (c) shall be met;
- (b) All mains connected apparatus shall employ a mains transformer complying with the insulation requirement given in IEC 60065:2001; and

- (c) Apparatus installed outdoors and operated from supply mains shall be contained in an appropriate drip-proof, splash-proof or water-tight enclosure so as to provide protection against moisture.

7.8.3 Safety bonding terminals

All amplifier housings, metallic mounting bays and racks shall be provided with an external safety bonding terminal complying with the relevant paragraphs of IEC 60065:2001.

Note: Taps, splitters etc may also be fitted with bonding terminals.

7.8.4 Connection to supply main

- (a) Connection of apparatus to the supply mains shall conform to the requirements of EMA; and
- (b) In the absence of any specific requirements by EMA, the following shall apply:
 - (i) The bonding terminal of the apparatus shall be connected to the earth conductor of the mains; and
 - (ii) If the design of the apparatus does not require it to be earthed, it shall then be clearly labelled and shall be isolated or enclosed with insulated materials.

Note: If different potentials build up between the earth conductor and the electrical earth of each apparatus, balancing current might flow and critical parts might be overheated.

7.8.5 Feeders bonding

- (a) Metal enclosures, especially those containing live equipment, shall be bonded in accordance with the requirements of EMA. All units within the enclosure shall be bonded to the enclosure;
- (b) The outer conductors of coaxial cables entering or leaving a building shall be carefully bonded to the earth conductors of the mains;
- (c) The outer conductor and its connections between any system outlet and any other outlet or bonding shall be able to carry a current of 30A for 5 seconds;
- (d) Provisions shall be made to maintain bonding while units are changed or removed;
- (e) The conductor connected to the bonding terminal shall be mechanically stable, and have a cross-sectional area of at least 4mm²;
- (f) The maximum value of earth-loop impedance shall comply with the EMA's requirement concerning earth leakage protection; and
- (g) Every connection of an earthing lead to an earthing point shall be readily accessible and soundly made by the use of clamps or soldered joints.

7.8.6 Proximity to power distribution systems

- (a) The cabled network shall be adequately protected against inadvertent contact with, or induction from electrical power distribution systems; and
- (b) EMA's requirements concerning the proximity of the cabled network to electrical power distribution systems and installations of any high-voltage network shall be strictly observed in all respects and at all times.

7.8.7 Remote power supply (over the coaxial cable)

- (a) The nominal r.m.s. voltage between the inner conductor and the outer conductor of the coaxial cable shall not exceed 65V; and
- (b) The installation for the remote power supply including the coaxial cable shall comply with EMA's requirement.

7.8.8 Weather protection

All apparatus and cables exposed to weather, corrosive atmosphere or other adverse conditions shall be so constructed or protected as may be necessary to prevent danger from arising from such exposure.

7.9 Minimum requirement of amplifiers

The amplifiers shall meet the minimum specifications set out hereunder:

- (a) The distribution amplifiers that will be cascaded, shall be operated with moderated trunk output levels in order to reduce the effects of accumulated distortions.
- (b) The minimum performance characteristics of the high gain amplifier shall be as follows:
 - (i) Noise figure with equaliser: ≤ 10 dB
 - (ii) Flatness in unity gain configuration: ± 1 dB
 - (iii) Forward bandwidth (downstream): 54-824 MHz
- (c) Amplifier housings shall be equipped with suitable means to prevent RF ingress and egress. When the cover is securely fastened, the housing shall have RF shielding effectiveness in excess of 80 dB when measured using the Dipole Antennae procedure, or in excess of 70 dB when measured using the Absorbing Clamp Method. The housing shall be of water tight construction, sealed with moisture blocking gaskets.
- (d) Amplifiers shall provide for the use of appropriate equalisers (input and/or inter-stage), and shall contain duplex filters providing sufficient isolation to avoid interaction between forward and reverse transmission.
- (e) Initial system configuration will accommodate broadband 54–824 MHz transmission for the digital terrestrial television operations.
- (h) Amplifiers shall not require automatic gain control ("AGC"), however, it is desirable to have the option of installing an AGC circuit on the initial amplifier in any network leg. This would compensate for any level variation that may be introduced from any subsequent antennae system.

7.10 Minimum requirements of passive devices: taps, splitters and system outlets

- (a) Splitters and bi-directional couplers may be either separately installed or combined in convenient groups to form multi-taps for use as distribution panels.
- (b) In order to minimise signal leakage (i.e. egress) from the installation, the screening effectiveness of splitters, bi-directional couplers and multi-tap combinations shall be either greater than 80 dB when measured using the Dipole Antennae Procedure, or greater than 70 dB when measured using the Absorbing Clamp Method.
- (c) The frequency response of all passive devices, including taps/tees, splitters, couplers and power inserters will be minimally 5 – 824 MHz.
- (d) To minimise signal reflections, devices that do not present a constant impedance match to the distribution cables should not be used. The return loss over the total frequency band shall be better than 12 dB.

7.11 Minimum requirements of connectors and splices

- (a) Connectors for subscriber feeder cables shall be F-type, with long (12-19 mm) attached ferrule. The connectors will utilise a compression sealed plastic ferrule bushing within the ferrule and a neoprene rubber gasket within the rotational joint in order to keep out moisture. In addition, it is recommended to seal the front end of the F type connectors with neoprene rubber boots which fit over the female F port and are compressed by the front face of the F type connector. Other connectors with similar characteristics and in every respect not less effective than that of the F type connectors may also be used.
- (b) Bulkhead fittings, cable connectors and splice barrels shall be compatible with each other and the coaxial cable used. This is particularly critical with respect to the diameter of the centre conductor and the clutch in the female fitting.
- (c) Suitable connectors and splices for solid sheath cables shall be used. Connectors will utilise a fixed sleeve with two separate ferrules to seize the other conductor and jacket of the cable independently. Connectors must be specifically designed for use with the coaxial cables types to be used.
- (d) Main distribution cables require the use of pin type connectors. Feed-through types are unacceptable. Connector return loss specifications shall equal or exceed 30 dB from 47 – 824 MHz. F-type connectors are not allowed on the main distribution cables.
- (e) Adapters between F connectors and housings or other devices shall be designed for use with each other and the coaxial cables used.
- (f) All connectors shall be installed and protected with properly applied shrink tubing in order to minimise corrosion or oxidation of cables and connectors.
- (g) All types of RF connectors, regardless of application, shall be mechanically, electrically and metallurgical suitable for use with the types of conductors used on various cables.

7.12 Protection against lightning

- (a) The elements and the boom of the antennae, the mast, the outer conductors of the antennae cables at inputs of the amplifiers and at the outputs of the amplifiers, should be bonded to the down conductors of the lightning protective system of the building.
- (b) The inner conductor of the antennae cables should be protected with surge diverters which are also bonded to the down conductors.
- (c) Metallic distribution conduits on roof-top should also be earthed.
- (d) Clamps and connectors used for securing the lightning conductors (or bonding cables) should be of electro-galvanised or stainless steel type.

7.13 Installation practices and procedures

7.13.1 Protection against moisture

The entire network shall be tightly sealed mechanically to prevent moisture from entering the electronic devices and coaxial cables.

7.13.2 Protection against corrosion shall be provided to metallic housing and devices. This is achieved by using any or all of the following methods:

- (a) Using corrosion-resistant material, such as stainless steel;
- (b) Galvanic protection;
- (c) Protective coating such as painting with rust-inhibiting paints; and
- (d) Other suitable corrosion prevention measures.

Where protective coatings are used, care should be taken to ensure electrical continuity.

7.13.3 Operating ambient conditions

All equipment shall be capable of continuous operation at ambient temperature up to 45°C and relative humidity of 100%.

7.14 Workmanship

7.14.1 All materials used shall be securely attached to permanent building walls or other structural members.

7.14.2 It is important to ensure that all F-type connectors are installed properly.

7.14.3 Adequate measures should be undertaken to ensure protection against moisture and corrosion.

7.14.4 Whilst installing the heat-shrink tubing over the connectors, particular attention should be paid to the need to ensure that the tubing has been shrunk uniformly and that the adhesive is effective throughout.

APPENDIX 1 FUNCTIONS OF THE TELECOMMUNICATION FACILITY COORDINATION COMMITTEE (“TFCC”) AND BUILDING PLAN COORDINATION AND APPROVAL PROCESS

1.1 Functions of the TFCC

The functions of the TFCC are as follow:

- (a) provide feedback to IMDA on its proposals for IMDA’s consideration regarding changes to the COPIF;
- (b) set-up pre-consultation meeting for building owners/ developers/ architects/ consultants on building facilities;
- (c) process building plans and appoint Building Plan Project Co-ordinator for specific building projects;
- (d) put up recommendations to IMDA on waiver of COPIF requirements;
- (e) ensure that licensees’ requirements are incorporated into the building plans submitted to TFCC; and
- (f) ensure the timely hand over of MDF room and in-building telecommunication facilities.

1.2 Building Plan Co-ordination and Approval Process

- (a) For large developments, the owner or developer may require pre-consultation meeting with the TFCC on the provision of telecommunication facilities. They may contact and arrange an appointment with the Secretariat of the TFCC. The TFCC Secretariat’s contact telephone number is 6848 4338.
- (b) For small developments or projects in which pre-consultation is not required, the owner or developer shall submit the building plans and the site plan to the TFCC through the BCA’s CORENET e-submission system.
- (c) The Building Plan Project Co-ordinator (appointed by the TFCC) will acknowledge the receipt of building plans. The co-ordinator will co-ordinate site meetings (with presence of representatives from licensees) to discuss in details on the provision of building telecommunication facilities. He/she will collate and forward final telecommunication service plan to building owners/ developers/ architects/ consultants and the other licensees. He/she will arrange for site inspection and MDF room hand-over when facilities are ready.
- (d) The flow chart for the building plan co-ordination and approval process is shown in the following diagram (Figure A1).

FIGURE A1 **FLOW CHART FOR BUILDING PLAN CO-ORDINATION & APPROVAL PROCESS (AN OVERVIEW)**

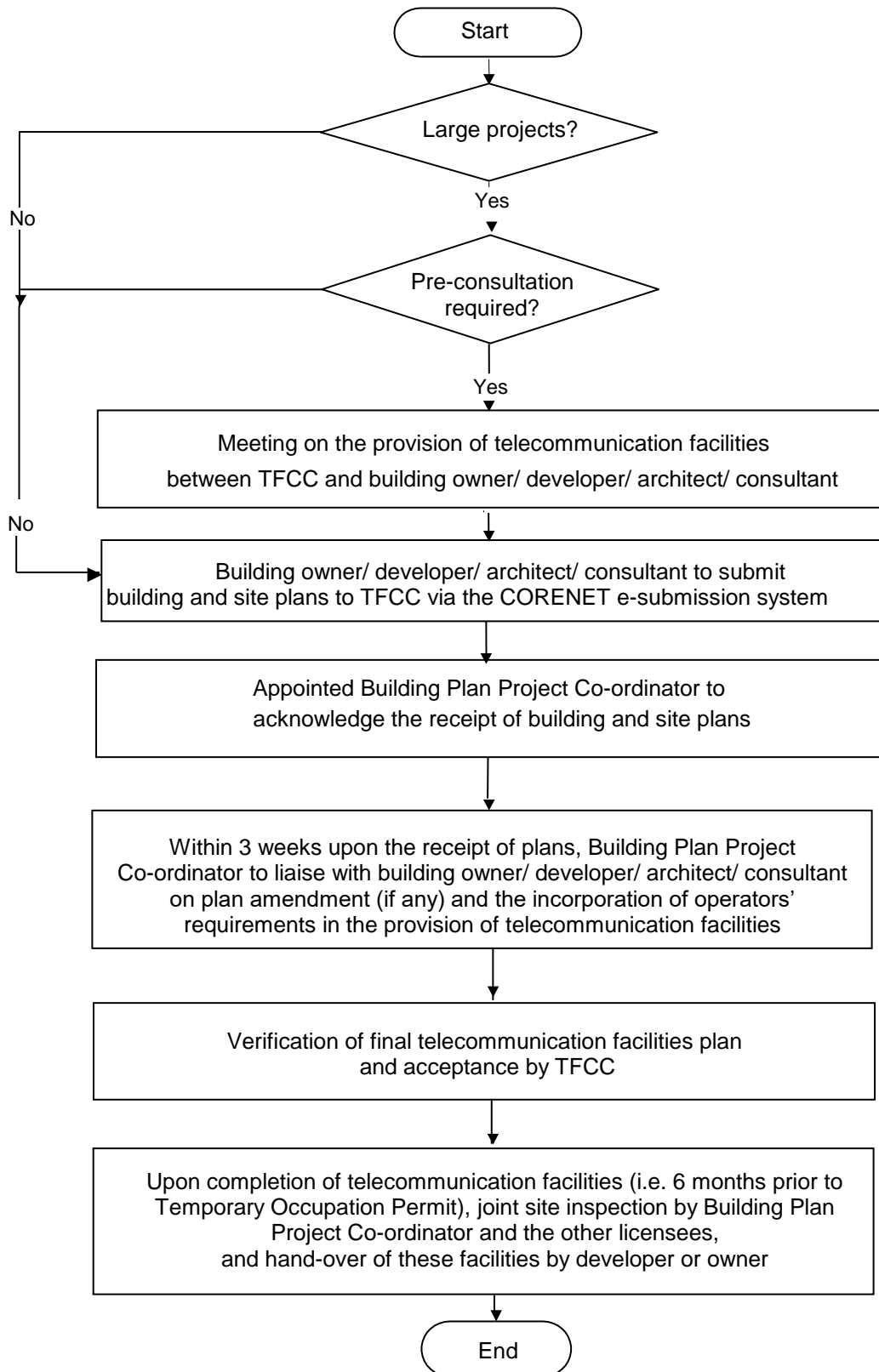

APPENDIX 2 DUCT SEALING SYSTEM FOR BUILDINGS WITH BASEMENT

2.1 Systems used

- (a) MCT – Transit for round holes/pipes, type RGP-150, split type.
- (b) ROX – Multi-diameter-modules with adaptable cores.
- (c) BST – Multi cable transit, modular system.

The typical view of a duct sealing system is shown in Figure A2.

2.2 Builder's responsibility

The developer or owner shall be responsible for the maintenance of the duct sealing system throughout the lifespan of the building, including ensuring there are no water leaks on the duct sealing system.

FIGURE A2 TYPICAL VIEW OF A CABLE DUCT SEALING SYSTEM

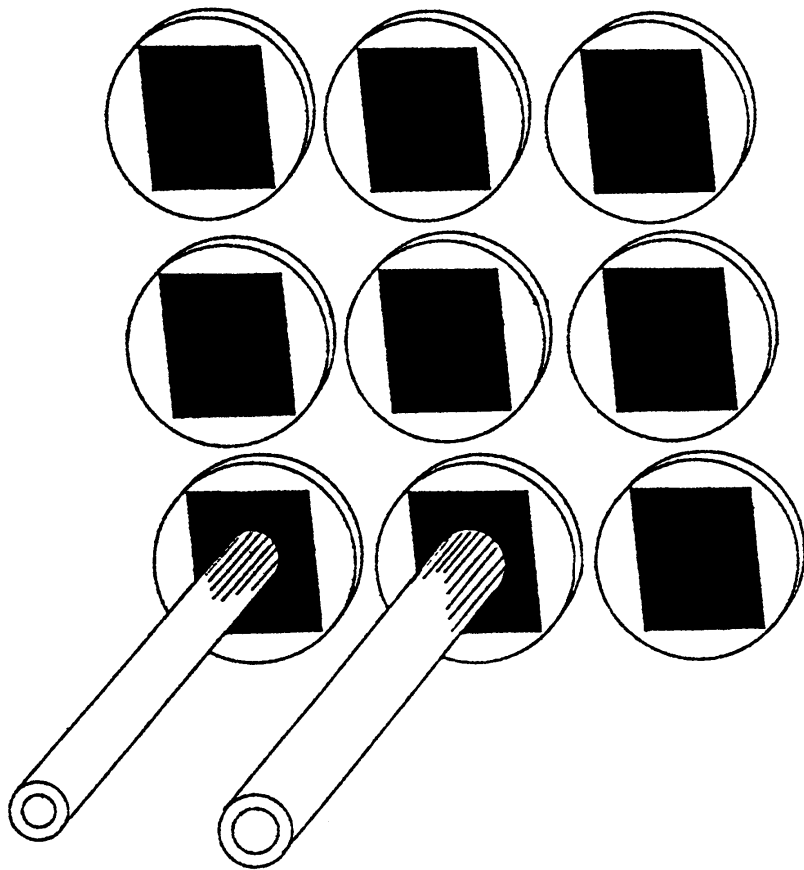

APPENDIX 3 TESTING AND ACCEPTANCE PROCEDURE FOR FACILITIES PROVIDED BY DEVELOPER OR OWNER

3.1 Testing Procedure

Upon completion of pipe-laying works, the developer or owner shall make arrangements with the licensees through the TFCC to have the pipes tested in accordance with the following procedures for:

(a) 110mm diameter nominal size uPVC Pipe

A brush of appropriate size shall be drawn through each pipe to remove any debris which may have entered. A standard wooden test mandrel as shown in Figure A3 shall then be drawn through each pipe from both ends of the pipe.

(b) 25mm and 50mm diameter nominal size uPVC Pipes

A 2m length of cable with diameter 15mm smaller than the internal diameter of the pipe shall be drawn through each pipe from both ends.

FIGURE A3 WOODEN MANDREL

