

CODE OF PRACTICE FOR INFO-COMMUNICATION FACILITIES IN BUILDINGS



May 2013

Table of Contents

CHAPTER 1. PRELIMINARY.....	1
1.1 Citation and commencement	1
1.2 Definitions.....	1
1.3 Purpose of this Code.....	5
1.4 Application of this Code	5
1.5 Waiver	7
1.6 Cancellation and transitional provisions.....	8
1.7 Guidelines	8
CHAPTER 2. OBLIGATION TO PROVIDE SPACE AND FACILITIES	9
2.1 Application of this chapter	9
2.2 Obligation to provide mobile deployment space	9
2.3 Charges for use of and access to relevant space and facilities.....	12
2.4 Space and facilities for exclusive use of licensees	13
2.5 Continuing obligation to provide access to and use of the relevant space and facilities	14
2.6 Continuing obligation to maintain the relevant space and facilities	15
2.7 Obligation to seal underground pipes	15
CHAPTER 3. SUBMISSION OF INFORMATION BY THE DEVELOPER OR OWNER	17
3.1 Application of this chapter	17
3.2 Submission of building plans to the Telecommunication Facility Co-ordination Committee (TFCC).....	17
CHAPTER 4. DEVELOPMENT CONSISTING OF 1 OR MORE LANDED DWELLING-HOUSES ABUTTING AN EXISTING ROAD	19
4.1 Application of this chapter	19
4.2 Provision of lead-in pipes and underground pipes.....	19
4.3 Provision of cables in underground pipes	20
4.4 Provision of internal telecommunication wiring.....	21
4.5 Provision of electrical switch socket outlet.....	21
4.6 Relevant space and facilities to be ready 3 months prior to the date of issuance of temporary occupation permit by the relevant authority.....	21
CHAPTER 5. DEVELOPMENT CONSISTING OF 2 OR MORE LANDED DWELLING-HOUSES ABUTTING A NEW ROAD TO BE CONSTRUCTED BY THE DEVELOPER OR OWNER.....	22
5.1 Application of this chapter	22
5.2 Provision of the main distribution frame room.....	22
5.3 Provision of underground pipes and manholes to serve the development.....	24
5.4 Provision of lead-in pipes and underground pipes for individual landed dwelling-houses.....	26
5.5 Provision of cables in the underground pipes	27
5.6 Provision of internal telecommunication wiring	27
5.7 Provision of electrical switch socket outlet.....	28
5.8 Relevant space and facilities to be ready 6 months prior to the date of issuance of temporary occupation permit by the relevant authority.....	28
CHAPTER 6. DEVELOPMENT CONSISTING OF 2 OR MORE STRATA LANDED DWELLING-HOUSES	29
6.1 Application of this chapter	29
6.2 Provision of the main distribution frame room.....	29
6.3 Provision of lead-in pipes, underground pipes and manholes	32
6.4 Provision of cable trays from the retaining wall to the main distribution frame room where there is basement level in the relevant development.....	33

6.5	Provision of cable trays from the main distribution frame room to each house	33
6.6	Provision of broadband coaxial cable system.....	34
6.7	Provision of conduits to each house	34
6.8	Provision of cables in the conduits.....	34
6.9	Provision of internal telecommunication wiring	35
6.10	Provision of electrical switch socket outlet.....	35
6.11	Provision of access to and use of the relevant space and facilities.....	35
6.12	Relevant space and facilities to be ready 6 months prior to the date of issuance of temporary occupation permit by the relevant authority	36
CHAPTER 7. DEVELOPMENT CONSISTING OF 1 OR MORE MULTI-STOREY RESIDENTIAL BUILDINGS		37
7.1	Application of this chapter	37
7.2	Provision of the main distribution frame room.....	37
7.3	Provision of lead-in pipes, underground pipes and manholes where there is no basement in the relevant development	40
7.4	Provision of lead-in pipes, underground pipes, manholes and cable trays where there is 1 or more basement level(s) in the development	42
7.5	Provision of telecommunication equipment rooms	44
7.6	Provision of the telecommunication risers	48
7.7	Provision of cable trays from the main distribution frame room or telecommunication equipment room to each telecommunication riser	50
7.9	Provision of conduits from the telecommunication risers to each residential unit	51
7.10	Provision of cables in the conduits.....	51
7.11	Provision of internal telecommunication wiring	52
7.12	Provision of electrical switch socket outlet.....	52
7.13	Provision of mobile deployment space	52
7.14	Provision of access to and use of the relevant space and facilities.....	55
7.15	Relevant space and facilities to be ready 6 months prior to the date of issuance of temporary occupation permit by the relevant authority	56
CHAPTER 8. DEVELOPMENT CONSISTING OF 1 OR MORE NON-RESIDENTIAL BUILDINGS OF A TOTAL USABLE FLOOR AREA OF MORE THAN 2,000m²		57
8.1	Application of this chapter	57
8.2	Provision of the main distribution frame room.....	57
8.3	Provision of lead-in pipes, underground pipes and manholes where there is no basement in the development	60
8.4	Provision of lead-in pipes, underground pipes, manholes and cable trays where there is a basement in the development	62
8.5	Provision of telecommunication risers	64
8.6	Provision of cable trays from the main distribution frame room to each telecommunication riser	66
8.7	Provision of a cable distribution system from the telecommunication riser to each non-residential unit	66
8.8	Provision of mobile deployment space	66
8.9	Provision of access to and use of the relevant space and facilities.....	68
8.10	Relevant space and facilities to be ready 6 months prior to the date of issuance of temporary occupation permit by the relevant authority	70
CHAPTER 9. DEVELOPMENT CONSISTING OF 1 OR MORE NON-RESIDENTIAL BUILDINGS OF A TOTAL USABLE FLOOR AREA OF UP TO AND INCLUDING 2,000m²		71
9.1	Application of this chapter	71
9.2	Provision of the main distribution frame room.....	71
9.3	Provision of lead-in pipes, underground pipes and manholes	73
9.4	Provision of telecommunication risers	74
9.5	Provision of horizontal cable trays from the main distribution frame room to each telecommunication riser	74

9.6	Provision of a cable distribution system from the telecommunication riser to each non-residential unit	75
9.7	Provision of mobile deployment space	75
9.8	Provision of access to and use of the relevant space and facilities.....	77
9.9	Relevant space and facilities to be ready 6 months prior to the date of issuance of temporary occupation permit by the relevant authority	78
CHAPTER 10 DEVELOPMENT CONSISTING OF 1 OR MORE ROAD OR MRT TUNNELS		79
10.1	Application of this chapter	79
10.2	Provision of mobile deployment space for road tunnel coverage	79
10.3	Provision of mobile deployment space for MRT tunnel coverage.....	79
10.4	Provision of access to and use of the relevant space and facilities.....	79
CHAPTER 11. LEAD-IN PIPES, UNDERGROUND PIPES AND MANHOLES		81
11.1	Overview	81
11.2	Qualified builders	81
11.3	General requirements for all pipes	81
11.4	Specific requirements for lead-in pipes.....	83
11.5	Specific requirements for the provision of underground pipes.....	84
11.6	Manholes.....	85
CHAPTER 12 MAIN DISTRIBUTION FRAME ROOM, TELECOMMUNICATION EQUIPMENT ROOM & MOBILE DEPLOYMENT SPACE		128
12.1	Overview	128
12.2	Location.....	128
12.3	Construction	129
12.4	Ventilation and air-conditioning.....	130
12.5	Electrical.....	131
12.6	Earthing	131
CHAPTER 13 TELECOMMUNICATION RISERS		132
13.1	Overview	132
13.2	General requirements	132
13.3	Internal wiring schedule	133
13.4	Placement of cables in telecommunication riser.....	134
CHAPTER 14 REQUIREMENTS FOR PROPER INSTALLATION OF A BROADBAND COAXIAL CABLE SYSTEM		135
14.1	General.....	135
14.2	Performance requirements for broadband coaxial cable system.....	135
14.3	Network topology	136
14.4	Cables	137
14.5	Safety	139
14.6	Installation practices and procedures	141
14.7	Workmanship	141
14.8	Other technical details.....	142
CHAPTER 15 REQUIREMENTS FOR INSTALLATION OF OPTICAL FIBRE CABLES IN RESIDENTIAL DEVELOPMENTS		143
15.1	General.....	143
15.2	Installation of optical fibre cable from telecommunication riser or gate pillar (or meter compartment) to each residential unit.....	143
15.3	Optical fibre cable specifications for installation in conduits	143
15.4	Optical fibre cable specifications for installation in underground pipe	144
15.5	Fibre interface point	144
15.6	Fibre termination point	144
15.7	Safety requirements	144
15.8	Testing criteria for the optical fibre cable from the telecommunication riser or gate pillar (or meter compartment) to each residential unit	145
15.9	Fibre Readiness Certification	146

CHAPTER 16 USE OF SPACE AND FACILITIES BY LICENSEES	147
16.1 Application of this chapter	147
16.2 Eligibility to use	147
16.3 Access to relevant space and facilities	147
16.4 Rules of usage	148
16.5 Sealing of underground pipes leading into an air-conditioned or unventilated main distribution frame room or telecommunication equipment room	149
16.6 Deployment of installation, plant or system	150
16.7 Connections to lead-in pipes.....	151
16.8 Concurrent deployment or connections by two or more licensees	152
16.9 Co-operation to resolve interference.....	153
16.10 Contravention by licensee.....	153
16.11 Provision of additional space or facilities	153
CHAPTER 17 USE OF SPACE AND FACILITIES WITHIN A DEVELOPMENT FOR THE PROVISION OF TELECOMMUNICATION SERVICES TO PROPERTIES OUTSIDE OF THE DEVELOPMENT	154
17.1 Application of this chapter	154
17.2 Overview	154
17.3 Procedures to be observed in relation to the use of COPIF space and facilities to serve external properties	155
17.4 Guiding principles on the use of COPIF space and facilities to serve external properties	156

**TELECOMMUNICATIONS ACT
(CHAPTER 323)**

**CODE OF PRACTICE FOR INFO-COMMUNICATION
FACILITIES IN BUILDINGS 2013**

In exercise of the powers conferred by section 19(1)(a) and (b) of the Telecommunications Act (Cap. 323), the Info-communications Development Authority of Singapore hereby issues the following Code of Practice:

CHAPTER 1. PRELIMINARY

1.1 Citation and commencement

This Code may be cited as the Code of Practice for Info-communication Facilities in Buildings 2013 and shall come into operation on 1 May 2013.

1.2 Definitions

In this Code, unless the context otherwise requires –

“broadband coaxial cable system” means a wide-area wired system of coaxial cables which connect to television outlets installed within a building for the transmission of cable services;

“building” means any permanent building or structure;

“cable” means a cable, wire or line used or intended to be used for telecommunications;

“cable distribution system” means a network of cable trays, cable ladders, trunking, conduits, and underfloor ducts, which enables cables to be laid from one point to another point within a building or a development;

“certificate of statutory completion” has the same meaning as in the Building Control Act (Cap. 29);

“construction” in relation to a building, means the erection, extension of, alteration and/or addition to the building, and “construct” and “constructed” shall be construed accordingly;

“development” means a single project (whether completed or not) consisting of 1 or more buildings, and includes all parcels of land comprised within the same project;

“duct” or “trunking” means an enclosed space which is used to house and conceal cables and includes spaces provided in a wall and in the skirting of walls and partitions;

“Effective Date” means the date this Code comes into operation;

“IDA” means the Info-communications Development Authority of Singapore constituted under the Info-communications Development Authority of Singapore Act (Cap. 137A);

“installation, plant or system” includes all structures, machinery, equipment, cables, poles and lines used or intended for use in connection with telecommunications;

“landed dwelling-house” means any of the following types of houses used wholly or mainly for the purpose of human habitation –

- (a) detached house;
- (b) semi-detached house; or
- (c) terrace house

but does not include a strata landed dwelling-house;

“lead-in pipes” in relation to –

- (a) a landed dwelling-house, means the pipes which extend outwards from the boundary of the house to enable the laying of cables from outside the property into the property; and
- (b) a development consisting of a building or buildings other than landed dwelling-houses, means the pipes which extend outwards from the boundary of the development to enable the laying of cables from outside the development into the development;

“licensee” means a telecommunication system licensee as defined in section 2 of the Telecommunications Act;

“main distribution frame” means the frame on which incoming main cables and the local distribution cables within a building or development are terminated and cross-connected;

“main distribution frame room” means a room within a building or development that is used to house a main distribution frame and licensees’ installation, plant or systems;

“mixed-use building” means a building used for both residential and non-residential purposes;

“mobile coverage area” refers to any area within a development which is to be served by any public cellular mobile telecommunication system;

“mobile deployment space” means the space to be set aside by the developer or owner for the deployment of installation, plant or systems by mobile telecommunication licensees;

“mobile telecommunication licensee” means a person that has been granted a licence by IDA to establish, install, operate and maintain telecommunication systems for the provision of public cellular mobile telecommunication services;

“multi-storey residential building” means a residential building, other than a landed dwelling-house or strata landed dwelling-houses, consisting of two or more storeys used wholly or mainly for the purpose of human habitation;

“non-residential building” means a building used for any non-residential purpose and includes –

- (a) office towers;
- (b) shophouses and shopping complexes;
- (c) convention and exhibition complexes;
- (d) markets and food centres;
- (e) hotels, boarding houses, guest houses, service apartments, student hostels and workers’ dormitories;
- (f) resort developments;
- (g) factories and warehouses;
- (h) utilities and telecommunication installations,
- (i) business or technology park developments;
- (j) airport or sea port terminals;
- (k) bus terminals, bus interchanges or train stations, including Mass Rapid Transit System (MRT) stations and Light Rail Transit System (LRT) stations;
- (l) fire stations, police stations, civil defence buildings, military camps, prison buildings, hospitals, government offices or embassies;
- (m) places of worship;
- (n) libraries, museums, community clubs or centres, association buildings, sports and recreational complexes, homes for the aged and hospices; and
- (o) primary schools, secondary schools, junior colleges, universities, polytechnics, foreign and specialist schools;

“previous codes” means any previously issued codes of practice or guidelines which specified the space and facilities to be provided by developers or owners of buildings for the purpose of enabling the

deployment and operation of installation or plant to provide telecommunication services to the buildings, including –

- (a) the Code of Practice for Info-communication Facilities in Buildings issued by IDA on 15 September 2008;
- (b) the Guidelines for Info-communications Facilities in Buildings issued by IDA on 15 September 2008 including its addendum dated 6 September 2011;
- (c) the Code of Practice for Info-communication Facilities in Buildings issued by IDA on 15 September 2000 including its addendums dated 15 March 2001 and 15 September 2006;
- (d) the Code of Practice for Telecommunication Facilities in Buildings issued by the Telecommunication Authority of Singapore in March 1997;
- (e) the Revised Guidelines for the Provision of Telecommunication Facilities by Developers issued by Singapore Telecommunications Ltd in 1994; and
- (f) the Guidelines for the Provision of Telecommunication Facilities by Developers issued by the Telecommunication Authority of Singapore in 1988;

“public road” means any road over which the public has a right of way;

“relevant space and facilities” means the space and facilities provided by the developer or owner of a building pursuant to this Code or any previous codes;

“RJ45 patch panel” means a panel for mounting RJ45 outlets for patching purposes;

“SC/APC connector” means standard connector / angle polished connector;

“strata landed dwelling-house” means a landed dwelling-house comprised in a development the strata sub-division of which is permitted under a written permission granted by the competent authority under section 14 (4) of the Planning Act (Cap. 232) or authorised by the Minister under section 21 (6) of the Planning Act;

“telecommunication equipment room” means a room within a building or a development that is used to house a licensee’s installation, plant or system;

“telecommunication riser” means a compartment that is used to house and distribute telecommunication cables to the individual storeys of a building;

“temporary occupation permit” has the same meaning as in the Building Control Act (Cap. 29);

“underground pipes” –

- (a) in relation to a landed dwelling-house, means the pipes which extend from the boundary of the house into the house;
- (b) in relation to a development consisting of strata landed dwelling-houses, means the pipes which extend from the boundary of the development to the main distribution frame room or to the retaining wall of the development (as the case may be) and which extend from the main distribution frame room or retaining wall to each strata landed dwelling-house within the development; and
- (c) in relation to a development consisting of a building or buildings other than landed dwelling-houses or strata landed dwelling-houses, means the pipes which extend from the boundary of the development to the main distribution frame room or to the retaining wall of the development (as the case may be) and which extend from the main distribution frame room or retaining wall to the telecommunication equipment room or telecommunication riser within the development; and

“usable floor area” refers to any floor space within a development which is to be served by any telecommunication system (excluding any floor spaces that are served only by public cellular mobile telecommunication systems).

1.3 Purpose of this Code

This Code specifies –

- (a) the space and facilities that the developer or owner of a land or building shall provide at his expense to enable the deployment and operation of installation, plant or systems to be used for telecommunications;
- (b) the duties that shall be observed by the developer or owner of a land or building in relation to the space and facilities provided within, or on, the land or building pursuant to this Code or previous codes; and
- (c) the duties that shall be observed by a licensee who deploys and operates its installation, plant or systems within the relevant space and facilities.

1.4 Application of this Code

- 1.4.1 Where a development has been granted provisional or written permission for its construction by the competent authority under the Planning Act (Cap. 232) on or after the Effective Date, the developer or owner of the development shall, unless he obtains a waiver from IDA in accordance with paragraph 1.5, provide at his expense the space and facilities described in chapters 4 to 10 as may be applicable.
- 1.4.2 Chapters 4 to 10 specify the space and facilities to be provided for the following types of development –

- (a) development consisting of 1 or more landed dwelling-houses abutting an existing road (Chapter 4);
- (b) development consisting of 2 or more landed dwelling-houses abutting a new road to be constructed by the developer or owner (Chapter 5);
- (c) development consisting of 2 or more strata landed dwelling-houses (Chapter 6);
- (d) development consisting of 1 or more multi-storey residential buildings (Chapter 7);
- (e) development consisting of 1 or more non-residential buildings of a total usable area of more than 2,000m² (Chapter 8);
- (f) development consisting of 1 or more non-residential buildings of a total usable area of up to and including 2,000m² (Chapter 9); and
- (g) development consisting of 1 or more road or MRT tunnels (Chapter 10).

1.4.3 Where a development consists of –

- (a) 1 or more mixed-use buildings; or
- (b) a mix of landed dwelling-houses, strata landed dwelling-houses, multi-storey residential buildings, non-residential buildings, mixed-use buildings or any combination thereof,

the developer or owner shall refer to and provide at his expense the relevant space and facilities specified in chapters 4 to 10 corresponding to the use or type of building in the development. For the avoidance of doubt, a set of space and facilities provided for the residential portion of a development shall not be counted towards the requirement for the relevant space and facilities for the non-residential portion or vice-versa. For example, in the case of a development consisting of a multi-storey mixed-use building, the developer or owner shall provide the space and facilities specified in chapter 7 in respect of the residential portion of the building and provide the space and facilities specified in chapter 8 or 9 (as the case may be) in respect of the non-residential portion of the building. In the event of any uncertainty as to the space and facilities to be provided, the developer or owner shall consult IDA for clarification.

1.4.4 Where the space and facilities to be provided for a particular development are not specified in this Code, the developer or owner shall consult IDA on the space and facilities to be provided at his expense for such development and comply with such requirements as may be imposed by IDA.

1.4.5 Where a development has been issued with a temporary occupation permit, regardless of when the development was constructed, the developer or owner shall comply with chapter 2 of this Code unless he obtains a waiver from IDA in accordance with paragraph 1.5.

- 1.4.6 Every developer or owner who is required to provide -
- (a) lead-in pipes, underground pipes or manholes;
 - (b) main distribution frame rooms;
 - (c) telecommunication equipment rooms;
 - (d) mobile deployment spaces;
 - (e) telecommunication risers;
 - (f) a broadband coaxial cable system; and/or
 - (g) optical fibre cables with associated fibre interface points and fibre termination points

pursuant to chapters 4 to 10 of this Code shall comply with the additional requirements set out in chapters 11 to 15 of this Code (as the case may be).

- 1.4.7 Every licensee who uses the space and facilities provided by the developer or owner of a development pursuant to this Code or any previous codes shall comply with chapter 16 of this Code.
- 1.4.8 Nothing in this Code shall limit IDA's power to issue a direction under section 21 of the Telecommunications Act.
- 1.4.9 For the avoidance of doubt, the developer or owner of a development shall not be excused from any failure to observe the requirements of this Code arising from acts or omissions of any consultant or contractor whom he engages to design and construct the development.

1.5 Waiver

- 1.5.1 IDA may, on receipt of an application in relation to the space and facilities to be provided in accordance with this Code, waive any of the requirements specified in this Code upon and subject to such terms and conditions as it thinks fit.
- 1.5.2 Any such application shall be made in writing to IDA by or on behalf of the developer or owner of the development to which such application relates and shall:
- (a) state the nature and extent of and reasons for the proposed waiver of such requirements; and
 - (b) be accompanied by such plans and particulars as may be required to support the application.
- 1.5.3 A waiver may be permanent, temporary (either for a fixed period or effective until the occurrence of a specific event) or on a one-time basis.

1.6 Cancellation and transitional provisions

- 1.6.1 The Code of Practice for Info-communications Facilities in Buildings issued by IDA in September 2008 (hereinafter referred to as the cancelled Code) is cancelled.
- 1.6.2 Notwithstanding paragraph 1.6.1, the cancelled Code shall in relation to buildings which are under construction on the Effective Date, continue to apply in relation to the space and facilities to be provided by the developer or owner as if that Code had not been cancelled. For the purposes of this paragraph, a building shall be under construction if either provisional or written permission for its construction had been granted under the Planning Act (Cap. 232) but no certificate of statutory completion had been issued in respect of the building.
- 1.6.3 For the avoidance of doubt, nothing in paragraph 1.6.1 shall exempt any developer or owner of a development from his obligation to provide space and facilities in accordance with the cancelled Code or any other previous code to the extent that the cancelled Code or other previous code applied to him prior to the Effective Date.
- 1.6.4 Nothing in paragraph 1.6.2 shall require any developer or owner to comply with the cancelled Code if he was not already required to do so before the Effective Date.
- 1.6.5 Where there is an agreement subsisting immediately before the Effective Date between the developer or owner of a development and a mobile telecommunication licensee pursuant to which the licensee is paying the developer or owner any fee or charge for the use of any space and facilities in the development for the deployment of its installation, plant or system, the developer or owner may designate such space and facilities as mobile deployment space for the purposes of this Code and may continue to collect the fee or charge payable in accordance with the agreement, provided that:
- (a) the space and facilities satisfy the requirements applicable to mobile deployment space as specified in this Code (including but not limited to requirements pertaining to size and location); and
 - (b) the developer or owner complies with all other provisions of this Code in relation to mobile deployment space.

1.7 Guidelines

- 1.7.1 The guidelines titled "Guidelines for Info-communication Facilities in Buildings" shall be read in conjunction with this Code. Developers and owners should refer to the guidelines for the technical specifications of the space and facilities to be provided under this Code and the recommended practices in relation to the construction thereof.

CHAPTER 2. OBLIGATION TO PROVIDE SPACE AND FACILITIES

2.1 Application of this chapter

2.1.1 This chapter specifies:

- (a) the obligations of the developer or owner of a development that has already been issued with a temporary occupation permit; and
- (b) the continuing obligations of the developer or owner relating to the use of, access to and maintenance of the relevant space and facilities, and liability for costs in relation thereto.

2.1.2 IDA reserves the right to require any developer or owner to provide additional space and facilities, to meet the demand for telecommunication services where necessary.

2.2 Obligation to provide mobile deployment space

2.2.1 If the relevant development consists of 1 or more multi-storey residential buildings, with 80 or more residential units, the developer or owner shall, where required and notified by any mobile telecommunication licensee, provide within a reasonable time, mobile deployment space in accordance with the dimensions specified in Table 2.2.1 based on the total number of residential units in the development. If the relevant development consists of more than 1500 residential units, the developer or owner shall consult IDA on the mobile deployment space to be provided and comply with such requirements as may be imposed by IDA.

Table 2.2.1 Mobile deployment space to be provided in each relevant development

Total number of residential units in the development	Mobile deployment space (m ²)		Minimum height of mobile deployment space (m)
	Where the mobile deployment space is provided as a single space	Where the mobile deployment space is provided as two or more separate spaces	
80 to 200	18	24*	3
201 to 600	36*		
601 to 1500	54*		
> 1500	To consult IDA		

* Size of each disaggregated MDS shall be at least 8m²

2.2.2 If the relevant development consists of 1 or more non-residential buildings (all of which are not tunnels) with a total mobile coverage area of more than 2,000m², the developer or owner shall, where required and notified by any mobile telecommunication licensee, provide within a reasonable time, mobile deployment space in accordance with the dimensions as specified in Table 2.2.2 based on the mobile coverage area in the development. If the relevant development consists of a total mobile coverage area of more than 200,000m², the developer or owner shall consult IDA on the mobile

deployment space to be provided and comply with such requirements as may be imposed by IDA.

Table 2.2.2 Mobile deployment space to be provided in each relevant development

Total mobile coverage area ('000 m ²)	Mobile deployment space (m ²)		Minimum height of mobile deployment space (m)
	Where the mobile deployment space is provided as a single space	Where the mobile deployment space is provided as two or more separate spaces	
> 2 to ≤ 6	18	24*	3
> 6 to ≤ 20	36*		
> 20 to ≤ 100	54*		
> 100 to ≤ 200	72*		
> 200	To consult IDA		

* Size of each disaggregated MDS shall be at least 8m²

2.2.3 The developer or owner may locate the mobile deployment space to be provided under paragraphs 2.2.1 and 2.2.2 at any unused space in the development (e.g. carpark and roof top), subject to the additional requirements provided in paragraphs 2.2.4 to 2.2.5 and chapter 12. For the avoidance of doubt, the mobile deployment space shall not be located in the main distribution frame room or the telecommunication equipment room, unless there is sufficient space available after having fulfilled the space requirements of the main distribution frame room or telecommunication equipment room and there is a clear demarcation of the space designated as mobile deployment space.

2.2.4 Where:

- (a) there is no basement level or a single basement level, the mobile deployment space shall be located on the first or higher storey of the relevant development; and
- (b) there are multiple basement levels, the mobile deployment space shall be located:
 - (i) on the first or higher storey; or
 - (ii) on the uppermost basement level provided that:
 - (A) in the event of flooding in the mobile deployment space leading to an outage in the provision of public cellular mobile telecommunication services supplied to the development, the developer or owner shall bear all costs incurred by the relevant licensee in restoring the public cellular mobile telecommunication services in the development except that where the relevant licensee is restoring such services to the development and external properties, the developer or owner shall only be obliged to bear a reasonable proportion of such costs attributable to the provision of public cellular mobile telecommunication services to the development;

- (B) in the event of flooding in the mobile deployment space leading to damage caused to any installation, plant or system of any licensee by the flooding, the developer or owner shall bear all costs incurred by the relevant licensee in replacing such damaged installation, plant or system of the licensee except that where such damaged installation, plant or system is also deployed by the licensee to serve external properties, the developer or owner shall only be obliged to bear a reasonable proportion of such costs attributable to the provision of public cellular mobile telecommunication services to the development;
- (C) in the event of flooding in the mobile deployment space leading to an outage in the provision of public cellular mobile telecommunication services supplied to the development and/or damage caused to any licensee's installation, plant or system, the developer or owner shall:
 - (I) promptly notify the residents or tenants of the development that public cellular mobile telecommunication services may be affected as a result of such event; and
 - (II) relocate the mobile deployment space to another location in the first or higher storey of the development and bear all costs in connection therewith except that where the installation, plant or system is also deployed by the licensee at the mobile deployment space to serve external properties, the developer or owner shall only be obliged to bear a reasonable proportion of such costs attributable to the provision of public cellular mobile telecommunication services to the development.

2.2.5 Where the relevant development comprises 1 or more buildings, any of which has 30 or more storeys, the developer or owner shall provide the mobile deployment space in 2 or more separate spaces, provided that the total space provided meets the relevant mobile deployment space and each separate space is at least 8m² with a minimum width of at least 2m. In determining the location of such spaces, the developer or owner shall locate them so as to facilitate the provision of public cellular mobile telecommunication services to the whole development.

2.2.6 Subject to paragraph 2.2.5, the developer or owner may provide the mobile deployment space in one or more separate spaces, provided that the total space meets the relevant mobile deployment space and each separate space is at least 8m² with a minimum width of at least 2m.

2.2.7 The developer or owner shall, at its own cost, comply with any legislation or regulatory requirements in connection with the provision of the mobile deployment space (e.g. obtaining the relevant approvals for conversion of car park lots to mobile deployment space, installation of fencing or trellis).

- 2.2.8 Where the licensee wishes to install any facilities (e.g. cable trays and power points) required to serve its installation, plant or system at the mobile deployment space, the developer or owner shall provide reasonable assistance to facilitate such installation by the licensee.
- 2.2.9 Without prejudice to paragraph 2.2.8, the developer or owner shall ensure that the electrical consumer switch room has sufficient power capacity (up to 32A, 3 phase 50Hz power supply per mobile telecommunication licensee) to supply electricity for the operation of the licensee's installation, plant or system in the development.
- 2.2.10 Subject to paragraph 17.4.7, where a licensee's installation, plant or system has been laid, placed, carried or erected in, on, over, under, upon, along or across the mobile deployment space, and the developer or owner desires to use the mobile deployment space in a manner which renders it necessary or convenient for such installation, plant or system to be altered, removed, relocated or diverted, the developer or owner may request the licensee to alter, remove, relocate or divert such installation, plant or system accordingly.
- 2.2.11 The licensee shall, at the request of the developer or owner under paragraph 2.2.10, alter, remove, relocate or divert the installation, plant or system if it is satisfied that such alteration, removal, relocation or diversion is reasonable and the owner or developer complies with such reasonable terms and conditions (which may include terms and conditions relating to the payment by the developer or owner of all costs and expenses necessary for such alteration, removal, relocation or diversion) as the licensee may impose.

2.3 Charges for use of and access to relevant space and facilities

- 2.3.1 The provision and maintenance of the space and facilities required to be provided under this Code or any previous codes shall, unless otherwise specified in this Code, be at the expense of the developer or owner of the development.
- 2.3.2 Without prejudice to the generality of paragraph 2.3.1 and subject to paragraph 2.3.4, no charges or rent (except as expressly provided for under this Code) shall be imposed on or collected from a licensee for its use of or access to the relevant space and facilities, including but not limited to –
- (a) main distribution frame rooms;
 - (b) telecommunication equipment rooms and coaxial distribution rooms;
 - (c) telecommunication risers;
 - (d) lead-in pipes, underground pipes and manholes;
 - (e) cable distribution systems; and
 - (f) mobile deployment space.
- 2.3.3 The developer or owner of a development shall provide lighting and ventilation to the relevant space and facilities (save for mobile deployment space) at his

own expense where this is necessary to enable a licensee to deploy and operate its installation, plant or system in such space and facilities.

- 2.3.4 Where the mobile deployment space is located in an enclosed space, the developer or owner of the development shall provide lighting and ventilation to the mobile deployment space at his own expense where this is necessary to enable a licensee to deploy and operate its installation, plant or system in such space and facilities.
- 2.3.5 The developer or owner of a development is not required to bear the utility charges for the operation of any installation, plant or system deployed by any licensee in the relevant space and facilities.
- 2.3.6 Where the developer or owner requires a licensee to bear the utility charges for the operation of any installation, plant or system deployed by the licensee in the relevant space and facilities, the developer or owner shall serve a notice to this effect on the licensee. The licensee shall bear the utility charges on a prospective basis commencing no earlier than a period of one (1) month from the date of service of such notice.
- 2.3.7 Where such notice as specified in paragraph 2.3.6 is served on the licensee, the developer or owner and the licensee shall reach an agreement on the basis upon which to compute the utility charges to be borne by the licensee. Where the developer or owner and the licensee are unable to agree on such basis, the utility charges to be borne by the licensee shall be based on the estimated power consumption of the licensee's installation, plant or system.
- 2.3.8 Notwithstanding paragraph 2.3.7, where it is physically feasible, the licensee may at its own cost, install the necessary electrical installations (including cables, a separate utility meter and any other accessory) to enable the utility charges to be computed on an "as incurred" basis and paid directly to the utilities provider.
- 2.3.9 For the avoidance of doubt, the developer or owner shall not require the licensee to bear any utility charges incurred prior to the commencement date referred to in paragraph 2.3.6.

2.4 Space and facilities for exclusive use of licensees

- 2.4.1 All space and facilities required to be provided under this Code or any previous codes shall be for the exclusive use of licensees.
- 2.4.2 The developer or owner of a development shall not use the relevant space and facilities for any purpose. In particular, the developer or owner shall not –
- (a) install main distribution frames, local distribution cables or any other equipment in the main distribution frame room, telecommunication equipment room, coaxial distribution room or mobile deployment space of the development for his own use whether for telecommunication purposes or otherwise;

- (b) install cables in the lead-in pipes, underground pipes, manholes, cable distribution system or telecommunication risers of the development for his own use whether for telecommunication purposes or otherwise; or
- (c) use the relevant space and facilities for the storage of any items whatsoever.

2.5 Continuing obligation to provide access to and use of the relevant space and facilities

- 2.5.1 The developer or owner of a development shall, upon reasonable notice being given by a licensee, grant the licensee access to and use of the space and facilities provided pursuant to this Code or any previous codes, for the licensee to inspect, install, maintain, repair and upgrade its installation, plant or system. Where the developer or owner objects to the licensee's intended access to and use of the space and facilities, the developer or owner shall raise its objection to the licensee within the stipulated timeframe in the notification and state the reasons for its objection. For the avoidance of doubt, the developer or owner shall ensure that its own internal processes do not cause any undue delay to the grant of such access under this paragraph 2.5.1.
- 2.5.2 Without prejudice to the generality of paragraph 2.5.1, the developer or owner shall, where it installs a false ceiling obstructing or covering any access to the relevant space and facilities (e.g. cable trays and metal trunking), provide appropriate access panels or openings.
- 2.5.3 The obligation of the developer or owner to provide access shall include removing and/or opening any temporary or permanent structures which are obstructing the licensee's access to the relevant space and facilities, at no cost to the licensee.
- 2.5.4 Where the developer or owner requires the licensee to submit any proposal for cabling works based on the relevant building plans, floor plans or blueprints, the developer or owner shall provide the licensee with at least one (1) set of the relevant building plans, floor plans or blueprints, at no cost to the licensee.
- 2.5.5 Where the relevant space and facilities are located at a height of more than 4m above floor level, the developer or owner shall provide the necessary means for the licensee to access such space and facilities in accordance with prevailing legislation or regulatory requirements on workplace safety and health, at no cost to the licensee. For the avoidance of doubt, this provision does not exempt any party from its relevant obligations under the prevailing legislation or regulatory requirements on workplace safety and health.
- 2.5.6 The developer or owner shall not impose any charge or rent on the licensee (e.g. administrative charges, security escort charges, costs to reinstate access panels or openings) or impose any additional requirements on the licensee (e.g. requiring any insurance policy or additional insurance coverage to be taken) in connection with the grant of access to and use of the space and facilities under paragraph 2.5.1. Without prejudice to the foregoing, the developer or owner may require that a licensee place a deposit in connection with any upgrading, installation or removal works to be carried out by the

licensee at the relevant space and facilities, provided that such deposit meets the following requirements:

- (a) the deposit must be refundable (subject to any deductions based on reasonable criteria that have been made known to the licensee in advance);
- (b) the deposit must be refunded to the licensee promptly after completion of the upgrading, installation or removal works; and
- (c) the deposit must be of a reasonable amount, taking into consideration the scope of the installation works.

2.6 Continuing obligation to maintain the relevant space and facilities

2.6.1 The developer or owner of a development shall, in relation to the space and facilities provided pursuant to this Code or any previous codes, at his own expense –

- (a) maintain the relevant space and facilities in a condition that is fit for the purpose of its use;
- (b) repair any part of the relevant space and facilities that falls into disrepair or is damaged unless such damage is caused by a licensee in which case the developer or owner may require the licensee, and the licensee shall be obliged, to carry out the necessary repairs (at the licensee's cost); and
- (c) implement reasonable measures to safeguard the security of the relevant space and facilities.

2.7 Obligation to seal underground pipes

2.7.1 Every developer or owner of a development who has provided or will be providing ventilation for the main distribution frame room and telecommunication equipment room by way of air-conditioning (or in any case where such room is enclosed with no louvres, exhaust fans or their equivalent) shall ensure that all unused underground pipes are sealed by the timeframe specified in Table 2.7.1 (based on the stage of completion of construction of the development) at the point of entry into such room, with a material that is durable, can be easily removed, and will not cause damage to the underground pipes or any telecommunication cables that may be used in the underground pipes, such that no foreign gaseous matter (which may be toxic or flammable) will pass through the underground pipes into such room.

Table 2.7.1 Timeframe for sealing of unused underground pipes by developer or owner

Stage of completion of construction	Timeframe for sealing
Buildings and developments under construction as at the Effective Date and the temporary occupation permit has not been issued	Prior to issuance of the temporary occupation permit
Buildings and developments that have been issued with the temporary occupation permit as at the Effective Date	Within 2 years of the Effective Date
New buildings and new developments	Prior to issuance of the temporary occupation permit

CHAPTER 3. SUBMISSION OF INFORMATION BY THE DEVELOPER OR OWNER**3.1 Application of this chapter**

- 3.1.1 This chapter specifies the requirements to be observed by the developer or owner of a development who is required to provide space and facilities under this Code.
- 3.1.2 Where a development has been granted provisional or written permission for its construction by the competent authority under the Planning Act (Cap. 232) on or after the Effective Date, the developer or owner shall ensure that the building plans for the development fully and accurately incorporate the requirements of this Code before construction commences.

3.2 Submission of building plans to the Telecommunication Facility Co-ordination Committee (TFCC)

- 3.2.1 The developer or owner shall submit the building plans to the Telecommunication Facility Co-ordination Committee ("TFCC") during the planning stage of the development together with the following information –
- (a) the name and contact details (including contact number and address) of the developer or owner;
 - (b) the names and contact details (including contact numbers and addresses) of the consultants and contractors engaged for the building works, including the architect, the M&E consultant and building contractors;
 - (c) the location of the development;
 - (d) the proposed number of units and the usable floor area;
 - (e) the intended use of the development;
 - (f) the estimated commencement and completion dates of the building works; and
 - (g) the house or unit numbering plan.
- 3.2.2 In addition to the information required in paragraph 3.2.1, the developer or owner shall submit –
- (a) the site plan indicating the location of the proposed development;
 - (b) building plans indicating the space and facilities (excluding mobile deployment space) provided for the development as specified in chapters 4 to 10 (as the case may be); and
 - (c) where a broadband coaxial cable system is required to be provided, the relevant design of such broadband coaxial cable system as specified in chapter 14.

- 3.2.3 The building plans, including the softcopy of drawings and cover letter detailing the information required under paragraphs 3.2.1 and 3.2.2, shall be submitted electronically to the TFCC via the Building and Construction Authority's CORENET e-Submission system.

CHAPTER 4. DEVELOPMENT CONSISTING OF 1 OR MORE LANDED DWELLING-HOUSES ABUTTING AN EXISTING ROAD

4.1 Application of this chapter

4.1.1 This chapter specifies the space and facilities to be provided for a development consisting of 1 or more landed dwelling-houses abutting an existing road. IDA reserves the right to require any developer or owner to provide additional space and facilities, to meet the demand for telecommunication services where necessary.

4.2 Provision of lead-in pipes and underground pipes

4.2.1 Subject to paragraph 4.2.2, every landed dwelling-house shall be provided, at the minimum, with –

- (a) 1 lead-in pipe for a telecommunication (coaxial cable) system which shall extend from the gate pillar of the house to the abutting road, to a point 1m beyond the roadside drain located immediately outside the house;
- (b) 1 lead-in pipe for a telecommunication (non-coaxial cable) system which shall extend from the gate pillar of the house to the abutting road, to a point 1m beyond the roadside drain located immediately outside the house;
- (c) 1 lead-in pipe for a telecommunication (spare) system which shall extend from the gate pillar of the house to the abutting road, to a point 1m beyond the roadside drain located immediately outside the house;
- (d) 1 underground pipe for a telecommunication (coaxial cable) system which shall run from the gate pillar of the house into the house, terminating at the utility room or closet;
- (e) 1 underground pipe for a telecommunication (non-coaxial cable) system which shall run from the gate pillar of the house into the house, terminating at the utility room or closet; and
- (f) 1 underground pipe for a telecommunication (spare) system which shall run from the gate pillar of the house into the house, terminating at the utility room or closet.

4.2.2 Where there is 1 or more existing pipe running from outside the development into the development, and the developer or owner intends to redevelop the development, the developer or owner shall provide the underground pipes required in paragraph 4.2.1 such that they are connected to the existing pipe running into the development as specified in Table 4.2.2, and the developer or owner shall also provide a reduced number of lead-in pipes as specified in Table 4.2.2.

Table 4.2.2 Manner in which new underground pipes are to be connected and number of new lead-in pipes to be provided

Number of existing pipes	Manner in which new underground pipes are to be connected	Number of new lead-in pipes to be provided
1	1 of the new underground pipes shall be connected to the existing pipe, and 2 of the new underground pipes shall be unconnected	2
2	2 of the new underground pipes shall be connected to the 2 existing pipes, and 1 of the new underground pipes shall be unconnected	1
3	All 3 of the new underground pipes shall be connected to the 3 existing pipes	0

4.2.3 For the purposes of paragraph 4.2.1 and 4.2.2, all lead-in pipes and underground pipes shall be made of unplasticised polyvinyl chloride (uPVC) material with a nominal diameter of 50mm and be compliant with the Singapore Standard SS:141 Class C.

4.2.4 In addition to the requirements set out in paragraphs 4.2.1 to 4.2.3, all lead-in pipes and underground pipes shall be provided in accordance with the requirements set out in chapter 11.

4.3 Provision of cables in underground pipes

4.3.1 With regard to the underground pipes referred to in paragraph 4.2.1 –

- (a) a minimum of 1 underground coaxial cable shall be provided in the underground pipe designated for a coaxial cable system, which shall terminate into a multi-way splitter or tap at one end (which may be located in the utility room or closet) and into a gate pillar at the other end. The underground coaxial cable shall be provided in accordance with the requirements set out in chapter 14;
- (b) a minimum of 1 2-core optical fibre cable complying with ITU-T G.652.D specifications shall be provided in the underground pipe designated for a non-coaxial cable system, which shall terminate into a fibre termination point with 2 sets of SC/APC connectors at one end (which may be located in the utility room or closet) and into a fibre interface point with 2 sets of SC/APC connectors located in the gate pillar at the other end. The 2-core optical fibre cable, SC/APC connectors, fibre termination point and fibre interface point shall be provided in accordance with the requirements set out in chapter 15; and
- (c) 1 draw rope shall be provided in the underground pipe designated for a telecommunication (spare) system.

4.4 Provision of internal telecommunication wiring

4.4.1 Every landed dwelling-house shall be provided, at the minimum, with –

- (a) RG6 coaxial cable(s) of a number equal to the total number of living room(s) and bedroom(s), which shall terminate into a multi-way splitter (which may be located in the utility room or closet) at one end, and into an F-type TV outlet in each of the living room(s) and bedroom(s) at the other end. The RG6 coaxial cable(s) shall be provided in accordance with the requirements set out in chapter 14;
- (b) unshielded twisted pair cable(s) (Category 6 or better) complying with TIA 568-C specifications of a number equal to the total number of bedroom(s), which shall terminate into an RJ45 patch panel (which may be located in the utility room or closet) at one end, and into an RJ45 outlet in each of the bedroom(s) at the other end. The length of each unshielded twisted pair cable shall not exceed 90m; and
- (c) unshielded twisted pair cable(s) (Category 6 or better) complying with TIA 568-C specifications of a number equal to 2 times the total number of living room(s), which shall terminate into an RJ45 patch panel (which may be located in the utility room or closet) at one end, and into 2 RJ45 outlets in each of the living room(s) at the other end. The length of each unshielded twisted pair cable shall not exceed 90m.

4.5 Provision of electrical switch socket outlet

4.5.1 Every landed dwelling-house shall be provided with a minimum of one 13A electrical switch socket outlet, which shall be placed adjacent to the fibre termination point referred to in paragraph 4.3.1(b).

4.6 Relevant space and facilities to be ready 3 months prior to the date of issuance of temporary occupation permit by the relevant authority

4.6.1 Where the developer or owner wishes to have telecommunications services provided to the development commencing from the date of issuance of the temporary occupation permit by the relevant authority ("TOP Date"), the developer or owner shall ensure that the relevant space and facilities (e.g. underground and lead-in pipes) are ready for use by the licensees at least 3 months before the TOP Date.

CHAPTER 5. DEVELOPMENT CONSISTING OF 2 OR MORE LANDED DWELLING-HOUSES ABUTTING A NEW ROAD TO BE CONSTRUCTED BY THE DEVELOPER OR OWNER

5.1 Application of this chapter

- 5.1.1 This chapter specifies the space and facilities to be provided for a development consisting of 2 or more landed dwelling-houses abutting a new road to be constructed by the developer or owner. All references to landed dwelling-houses in this chapter shall refer only to such type of houses. IDA reserves the right to require any developer or owner to provide additional space and facilities, to meet the demand for telecommunication services where necessary.
- 5.1.2 If the relevant development consists of more than 1500 landed dwelling-houses, the developer or owner shall consult IDA on the space and facilities to be provided and comply with such requirements as may be imposed by IDA.

5.2 Provision of the main distribution frame room

- 5.2.1 A minimum of 1 main distribution frame room shall be provided in every relevant development, which shall be constructed at such location within the relevant development as the developer or owner considers appropriate.
- 5.2.2 The size of the main distribution frame room to be provided under paragraph 5.2.1 shall be based on the total number of landed dwelling-houses in the relevant development as specified in Table 5.2.2.

Table 5.2.2 Size of main distribution frame room to be provided in each relevant development

Total number of landed dwelling-houses in the development	Minimum floor area of main distribution frame room (m ²)	Minimum height of main distribution frame room (m)
2 – 10	4	3.5
11 – 20	5	
21 – 30	6	
31 – 60	8	
61 – 120	12	
121 – 200	16	
201 – 400	20	
401 – 600	30	
601 – 800	42	
801 – 1000	49	
1001 – 1500	56	

- 5.2.3 Where the floor area to be provided for the main distribution frame room is up to and including 6m², the minimum width of the room shall be 2m. The ratio of the length and width to be provided for a main distribution frame room with a floor area of greater than 6m² shall be between 1:1 and 2:1.

5.2.4 The developer or owner shall provide for ventilation of the main distribution frame room by way of louvres and/or exhaust fans in accordance with the requirements set out in chapter 12.

5.2.5 Where a relevant development consists of a total of up to 30 landed dwelling-houses –

- (a) 3 sets of electrical distribution panels operating on 230V, single phase, 50Hz power supply connecting to the switch socket outlets; and
- (b) 20A isolators

shall be provided in every main distribution frame room in accordance with paragraphs 5.2.7 and 5.2.8.

5.2.6 Where a relevant development consists of a total of more than 30 but up to 1500 landed dwelling-houses –

- (a) 3 sets of electrical distribution panels operating on 230V, single phase, 50Hz power supply connecting to the switch socket outlets; and
- (b) 30A isolators

shall be provided in every main distribution frame room in accordance with paragraphs 5.2.7 and 5.2.8.

5.2.7 Every electrical distribution panel shall contain –

- (a) a 30mA residual current circuit breaker of appropriate electrical current rating and miniature circuit breakers for final circuit connections and to facilitate the installation of electrical meters;
- (b) 2 spare 20A miniature circuit breakers; and
- (c) a single-line diagram in each panel.

5.2.8 Switch socket outlets and isolators shall be provided in the main distribution frame room in accordance with the quantities specified in Table 5.2.8 which are to be distributed evenly between the 3 sets of electrical distribution panels.

Table 5.2.8 Requirements of switch socket outlets and isolators to be provided in the main distribution frame room of each relevant development

Total number of landed dwelling-houses in the development	Minimum number of switch socket outlets to be provided in main distribution frame room	Minimum number of isolators to be provided in main distribution frame room
30 or below	3 x 2-gang 13A	3 x 20A
31 – 200	3 x 2-gang 13A	3 x 30A
201 – 1500	3 x 2-gang 13A	6 x 30A

- 5.2.9 Natural or electrical lighting (or both) shall be provided in the main distribution frame room.
- 5.2.10 A clean earth of 1Ω or less (without the use of salt) shall be provided for the exclusive use of licensee's installation or plant in the main distribution frame room. The clean earth shall be connected directly to:
- (i) an independent earth electrode system; and
 - (ii) the development's electrical safety earth system.
- 5.2.11 Where a relevant development consists of a total of up to 120 landed dwelling-houses, the clean earth that is provided pursuant to paragraph 5.2.10 shall be in the form of a copper earth bar of at least 300mm in length, 8mm in width and 5mm in thickness, with screw holes that are 6mm in diameter.
- 5.2.12 Where a relevant development consists of a total of more than 120 but up to 1500 landed dwelling-houses, the clean earth that is provided pursuant to paragraph 5.2.10 shall be in the form of a copper earth bar of at least 600mm in length, 8mm in width and 5mm in thickness, with screw holes that are 6mm in diameter.
- 5.2.13 In addition to the requirements set out in paragraphs 5.2.1 to 5.2.12, the main distribution frame room shall be provided in accordance with the requirements set out in chapter 12.

5.3 Provision of underground pipes and manholes to serve the development

- 5.3.1 The developer or owner shall provide underground pipes within the development to –
- (a) enable licensees to link their cables from outside the development to the main distribution frame room; and
 - (b) enable the landed dwelling-houses within the development to be served by the main distribution frame room.
- 5.3.2 The underground pipes shall extend from the main distribution frame room to the nearest new road to be constructed by the developer or owner and shall run along the new road(s) to the boundary of the development and to all houses that are to be served by the main distribution frame room.
- 5.3.3 The number of underground pipes to be provided shall be in accordance with the quantities specified in Table 5.3.3. With the exception of the underground pipes terminating at the boundary of the development, the number of underground pipes provided to other areas within the development may be gradually reduced based on the houses served subject to consultation with IDA.

Table 5.3.3 Number of underground pipes to be provided from the main distribution frame room to serve the development

Total number of landed dwelling-houses in the development	Total number of underground pipes to be provided
< 200	8
201 – 400	10
401 – 600	12
601 – 800	14
801 – 1000	16
1001 – 1500	18

- 5.3.4 When entering the main distribution frame room, the underground pipes shall be configured in accordance with the formation specified in Table 5.3.4.

Table 5.3.4 Underground pipe formation in main distribution frame room

Total number of landed dwelling-houses in the development	Pipe formation in the main distribution frame room
< 200	2 x 4
201 – 400	2 x 5
401 – 600	2 x 6
601 – 800	2 x 7
801 – 1000	2 x 8
1001 – 1500	2 x 9

- 5.3.5 All underground pipes shall be made of unplasticised polyvinyl chloride (uPVC) material with a nominal diameter of 110mm and be compliant with the Singapore Standard SS:272.
- 5.3.6 In addition to the requirements set out in paragraphs 5.3.1 to 5.3.5, all underground pipes shall be provided in accordance with the requirements set out in chapter 11.
- 5.3.7 Manholes shall be provided for the underground pipes within each relevant development as follows –
- (a) a manhole shall be constructed at every location where there is effectively an approximately 90° or sharper bend in the direction of the underground pipes; and
 - (b) a minimum of 1 manhole must be provided for every 150m segment of underground pipes laid.
- 5.3.8 The type of manholes to be provided under paragraph 5.3.7 shall be in accordance with Table 5.3.8 based on the highest number of underground pipes entering any one side of the manhole.

Table 5.3.8 Type of manholes to be provided

Highest number of underground pipes entering any one side of the manhole	Type of manhole to be provided
≤ 2	JX2
3 to 6	MX1
7 to 9	MX2
10 to 12	MX3
13 to 16	MX4
17 to 24	MX5

5.3.9 A minimum space of –

- (a) 1500mm x 650mm in dimension; or
- (b) 500mm x 500mm in dimension

shall be set aside in close proximity to every manhole to facilitate the construction of a pedestal used for the deployment of broadband coaxial cable systems. The developer or owner shall consult the relevant licensee on the appropriate minimum space to be set aside. A minimum of 2 pipes (to be laid underground) of 110mm nominal diameter shall be provided from the manhole to the allocated space, which shall protrude at least 300mm above the ground level at the allocated space.

5.3.10 In addition to the requirements set out in paragraphs 5.3.7 to 5.3.9, all manholes shall be provided in accordance with the requirements set out in chapter 11.

5.4 Provision of lead-in pipes and underground pipes for individual landed dwelling-houses

5.4.1 Every landed dwelling-house shall be provided, at the minimum, with –

- (a) 1 lead-in pipe for a telecommunication (coaxial cable) system which shall extend from the gate pillar of the house to the new abutting road to be constructed by the developer, and connect from there to the nearest manhole provided in accordance with paragraph 5.3;
- (b) 1 lead-in pipe for a telecommunication (non-coaxial cable) system which shall extend from the gate pillar of the house to the new abutting road to be constructed by the developer, and connect from there to the nearest manhole provided in accordance with paragraph 5.3;
- (c) 1 lead-in pipe for a telecommunication (spare) system which shall extend from the gate pillar of the house to the new abutting road to be constructed by the developer, and connect from there to the nearest manhole provided in accordance with paragraph 5.3;
- (d) 1 underground pipe for a telecommunication (coaxial cable) system which shall run from the gate pillar of the house into the house, terminating at the utility room or closet;

- (e) 1 underground pipe for a telecommunication (non-coaxial cable) system which shall run from the gate pillar of the house into the house, terminating at the utility room or closet; and
- (f) 1 underground pipe for a telecommunication (spare) system which shall run from the gate pillar of the house into the house, terminating at the utility room or closet.

5.4.2 For the purposes of paragraph 5.4.1, all lead-in pipes and underground pipes shall be made of unplasticised polyvinyl chloride (uPVC) material with a nominal diameter of 50mm and be compliant with the Singapore Standard SS:141 Class C.

5.4.3 In addition to the requirements set out in paragraphs 5.4.1 and 5.4.2, all lead-in pipes and underground pipes shall be provided in accordance with the requirements set out in chapter 11.

5.5 Provision of cables in the underground pipes

5.5.1 With regard to the underground pipes referred to in paragraph 5.4.1 –

- (a) a minimum of 1 underground coaxial cable shall be provided in the underground pipe designated for a coaxial cable system, which shall terminate into a multi-way splitter at one end (which may be located in the utility room or closet) and into a gate pillar at the other end. The underground coaxial cable shall be provided in accordance with the requirements set out in chapter 14; and
- (b) a minimum of 1 2-core optical fibre cable complying with ITU-T G.652.D specifications shall be provided in the underground pipe designated for a non-coaxial cable system, which shall terminate into a fibre termination point with 2 sets of SC/APC connectors at one end (which may be located in the utility room or closet) and into a fibre interface point with 2 sets of SC/APC connectors located in the gate pillar at the other end. The 2-core optical fibre cable, SC/APC connectors, fibre termination point and fibre interface point shall be provided in accordance with the requirements set out in chapter 15; and
- (c) 1 draw rope shall be provided in the underground pipe designated for a telecommunication (spare) system.

5.6 Provision of internal telecommunication wiring

5.6.1 Every landed dwelling-house shall be provided, at the minimum, with –

- (a) RG6 coaxial cable(s) of a number equal to the total number of living room(s) and bedroom(s), which shall terminate into a multi-way splitter (which may be located in the utility room or closet) at one end and into an F-type TV outlet in each of the living room(s) and bedroom(s) at the

other end. The RG6 coaxial cable(s) shall be provided in accordance with the requirements set out in chapter 14;

- (b) unshielded twisted pair cable(s) (Category 6 or better) complying with TIA 568-C specifications of a number equal to the total number of bedroom(s), which shall terminate into an RJ45 patch panel (which may be located in the utility room or closet) at one end, and into an RJ45 outlet in each of the bedroom(s) at the other end. The length of each unshielded twisted pair cable shall not exceed 90m; and
- (c) unshielded twisted pair cable(s) (Category 6 or better) complying with TIA 568-C specifications of a number equal to 2 times the total number of living room(s), which shall terminate into an RJ45 patch panel (which may be located in the utility room or closet) at one end, and into 2 RJ45 outlets in each of the living room(s) at the other end. The length of each unshielded twisted pair cable shall not exceed 90m.

5.7 Provision of electrical switch socket outlet

- 5.7.1 Every landed dwelling-house shall be provided with a minimum of one 13A electrical switch socket outlet which shall be placed adjacent to the fibre termination point referred to in paragraph 5.5.1(b).

5.8 Relevant space and facilities to be ready 6 months prior to the date of issuance of temporary occupation permit by the relevant authority

- 5.8.1 Where the developer or owner wishes to have telecommunication services provided to the development starting from the date of issuance of the temporary occupation permit by the relevant authority ("TOP Date"), the developer or owner shall ensure that the relevant space and facilities (e.g. main distribution frame room, underground and lead-in pipes) are ready for use by the licensees at least 6 months before the TOP Date.

CHAPTER 6. DEVELOPMENT CONSISTING OF 2 OR MORE STRATA LANDED DWELLING-HOUSES

6.1 Application of this chapter

- 6.1.1 This chapter specifies the space and facilities to be provided for a development consisting of 2 or more strata landed dwelling-houses. IDA reserves the right to require any developer or owner to provide additional space and facilities, to meet the demand for telecommunication services where necessary.
- 6.1.2 If the relevant development consists of more than 200 strata landed dwelling-houses, the developer or owner shall consult IDA on the space and facilities to be provided and comply with such requirements as may be imposed by IDA.

6.2 Provision of the main distribution frame room

- 6.2.1 A main distribution frame room shall be provided in every relevant development. Where:
- (a) there is no basement level or a single basement level, the main distribution frame room shall be located on the first or second storey of the relevant development; and
 - (b) there are multiple basement levels, the main distribution frame room shall be located:
 - (i) on the first or second storey; or
 - (ii) on the uppermost basement level provided that:
 - (A) in the event of flooding in the main distribution frame room leading to an outage in the provision of telecommunication services supplied to the development, the developer or owner shall bear all costs incurred by the relevant licensee in restoring the telecommunication services in the development except that where the relevant licensee is restoring such services to the development and external properties, the developer or owner shall only be obliged to bear a reasonable proportion of such costs attributable to the provision of telecommunication services to the development;
 - (B) in the event of flooding in the main distribution frame room leading to damage caused to any installation, plant or system of any licensee by the flooding, the developer or owner shall bear all costs incurred by the relevant licensee in replacing such damaged installation, plant or system of the licensee except that where such damaged installation, plant or system is also deployed by the licensee to serve external properties, the developer or owner shall only be

obliged to bear a reasonable proportion of such costs attributable to the provision of telecommunication services to the development; and

- (C) in the event of flooding in the main distribution frame room leading to an outage in the provision of telecommunication services supplied to the development and/or damage caused to any licensee's installation, plant or system, the developer or owner shall:
- (I) promptly notify the residents of the development that telecommunication services may be affected as a result of such event; and
 - (II) relocate the main distribution frame room to another location in the first or second storey of the development and bear all costs in connection therewith except that where the installation, plant or system is deployed by the licensee in the main distribution frame room to serve external properties, the developer or owner shall only be obliged to bear a reasonable proportion of such costs attributable to the provision of telecommunication services to the development.

6.2.2 The size of the main distribution frame room to be provided under paragraph 6.2.1 shall be based on the total number of strata landed dwelling-houses in the relevant development as specified in Table 6.2.2.

Table 6.2.2 Size of main distribution frame room to be provided in each relevant development

Total number of strata landed dwelling-houses in the development	Minimum floor area of main distribution frame room (m ²)	Minimum height of main distribution frame room (m)
2 – 10	4	3.5
11 – 20	5	
21 – 30	6	
31 – 60	8	
61 – 120	12	
121 – 200	16	

6.2.3 Where the floor area to be provided for the main distribution frame room is up to and including 6m², the minimum width of the main distribution frame room shall be 2m. The ratio of the length and width to be provided for a main distribution frame room with a floor area of greater than 6m² shall be between 1:1 and 2:1.

6.2.4 The developer or owner shall provide for ventilation of the main distribution frame room by way of louvres and/or exhaust fans in accordance with the requirements set out in chapter 12.

6.2.5 Where a relevant development consists of a total of up to 30 strata landed dwelling-houses:-

- (a) 3 sets of electrical distribution panels operating on 230V, single phase, 50 Hz power supply connecting to the switch socket outlets; and
- (b) 20A isolators

shall be provided in the main distribution frame room in accordance with paragraphs 6.2.7 and 6.2.8.

6.2.6 Where a relevant development consists of a total of more than 30 but up to 200 strata landed dwelling-houses:-

- (a) 3 sets of electrical distribution panels operating on 230V, single phase, 50 Hz power supply connecting to the switch socket outlets; and
- (b) 30A isolators

shall be provided in the main distribution frame room in accordance with paragraphs 6.2.7 and 6.2.8.

6.2.7 Every electrical distribution panel shall contain –

- (a) a 30mA residual current circuit breaker of appropriate electrical current rating and miniature circuit breakers for final circuit connections and to facilitate the installation of electrical meters;
- (b) 2 spare 20A miniature circuit breakers; and
- (c) a single-line diagram in each panel.

6.2.8 Switch socket outlets and isolators shall be provided in the main distribution frame room in accordance with the quantities specified in Table 6.2.8 which are to be distributed evenly between the 3 sets of electrical distribution panels.

Table 6.2.8 Requirements of switch socket outlets and isolators to be provided in the main distribution frame room of each relevant development

Total number of strata landed dwelling-houses in the development	Minimum number of switch socket outlets to be provided in main distribution frame room	Minimum number of isolators to be provided in the main distribution frame room
30 or below	3 x 2-gang 13A	3 x 20A
31 – 200	3 x 2-gang 13A	3 x 30A

6.2.9 Where a standby power generator is provided in the relevant development, the power supply to the main distribution frame room shall be connected to such standby power generator.

- 6.2.10 Where a standby power generator is not provided in the relevant development, the 20A or 30A isolators (as the case may be) in the main distribution frame room shall be connected to power sockets for connection to portable power generators and equipped with a manually activated switch to effect the changeover.
- 6.2.11 Natural and/or electrical lighting shall be provided in the main distribution frame room.
- 6.2.12 A clean earth of 1Ω or less (without the use of salt) shall be provided for the exclusive use of licensees' installation or plant in the main distribution frame room. The clean earth shall be connected directly to:
- (a) an independent earth electrode system; and
 - (b) the development's electrical safety earth system.
- 6.2.13 Where a relevant development consists of a total of up to 120 strata landed dwelling-houses, the clean earth that is provided pursuant to paragraph 6.2.12 shall be in the form of a copper earth bar of at least 300mm in length, 8mm in width and 5mm in thickness, with screw holes that are 6mm in diameter.
- 6.2.14 Where a relevant development consists of a total of more than 120 but up to 200 strata landed dwelling-houses, the clean earth that is provided pursuant to paragraph 6.2.12 shall be in the form of a copper earth bar of at least 600 mm in length, 8mm in width and 5mm in thickness, with screw holes that are 6mm in diameter.
- 6.2.15 In addition to the requirements set out in paragraphs 6.2.1 to 6.2.14, the main distribution frame room shall be provided in accordance with the requirements set out in chapter 12.

6.3 Provision of lead-in pipes, underground pipes and manholes

- 6.3.1 Eight (8) continuous lead-in pipes and underground pipes shall be provided for the relevant development as follows –
- (a) the lead-in pipes shall extend from the boundary of the development to the abutting road, to a point 1 m beyond the roadside drain located immediately outside the development; and
 - (b) the underground pipes shall connect from the lead-in pipes at the boundary of the development and run to the retaining wall of the development if there is any basement level in the development, or to the main distribution frame room if there is no basement level in the development.
- 6.3.2 Where underground pipes are provided to the main distribution frame room, such pipes shall enter the room in a formation of 2 rows x 4 pipes.
- 6.3.3 For the purposes of paragraph 6.3.1, all lead-in pipes and underground pipes shall be made of unplasticised polyvinyl chloride (uPVC) material with a

nominal diameter of 110mm and be compliant with the Singapore Standard SS:272.

- 6.3.4 A cable duct sealing module system shall be installed at the retaining wall of the relevant development to prevent any ingress of water flowing from the underground pipes into the basement.
- 6.3.5 In addition to the requirements set out in paragraphs 6.3.1 to 6.3.4, all lead-in pipes and underground pipes shall be provided in accordance with the requirements set out in chapter 11.
- 6.3.6 Manholes shall be provided in each relevant development as follows –
- (a) a manhole shall be constructed at every location where there is effectively an approximately 90° or sharper bend in the direction of the underground pipes; and
 - (b) a minimum of 1 manhole must be provided for every 150m segment of underground pipes laid.
- 6.3.7 The manholes to be provided under paragraph 6.3.6 shall be of type MX2.
- 6.3.8 In addition to the requirements set out in paragraphs 6.3.6 to 6.3.7, all manholes shall be provided in accordance with the requirements set out in chapter 11.

6.4 Provision of cable trays from the retaining wall to the main distribution frame room where there is basement level in the relevant development

- 6.4.1 A minimum of 2 cable trays shall be provided from the retaining wall of the relevant development to the main distribution frame room, of which -
- (a) a minimum of 1 cable tray shall be used for non-coaxial cables; and
 - (b) a minimum of 1 cable tray shall be used for coaxial cables.
- 6.4.2 The total width of these cable trays shall cover the total cross-sectional width of the underground pipes terminating at the retaining wall.

6.5 Provision of cable trays from the main distribution frame room to each house

- 6.5.1 A minimum of 2 cable trays with a minimum width of 200mm shall be provided from the main distribution frame room to each strata landed dwelling-house, of which –
- (a) a minimum of 1 cable tray shall be used for non-coaxial cables; and
 - (b) a minimum of 1 cable tray shall be used for coaxial cables.

6.6 Provision of broadband coaxial cable system

- 6.6.1 A broadband coaxial cable system shall be provided from the main distribution frame room to each strata landed dwelling-house. The broadband coaxial cable system shall be provided in accordance with chapter 14.

6.7 Provision of conduits to each house

- 6.7.1 Every strata landed dwelling-house in the relevant development shall be provided, at the minimum, with –
- (a) 1 conduit of a minimum size of 20mm in diameter for a telecommunication (non-coaxial cable) system which shall run from the location where the cable trays referred to in paragraph 6.5 terminate, into each strata landed dwelling-house, and terminating at the utility room or closet;
 - (b) 1 conduit of a minimum size of 20mm in diameter for a telecommunication (coaxial cable) system which shall run from the location where the cable trays referred to in paragraph 6.5 terminate, into each strata landed dwelling-house, and terminating at the utility room or closet; and
 - (c) 1 conduit of a minimum size of 20mm in diameter for a telecommunication (spare) system which shall run from the location where the cable trays referred to in paragraph 6.5 terminate, into each strata landed dwelling-house, and terminating at the utility room or closet.

6.8 Provision of cables in the conduits

- 6.8.1 With regard to the conduits referred to in paragraph 6.7.1 –
- (a) a minimum of 1 coaxial cable shall be provided in the conduit designated for a coaxial cable system, which shall terminate into a multi-way splitter at one end (which may be located in the utility room or closet) and into a tap or splitter box located outside the strata landed dwelling-house at the other end. The coaxial cable shall be provided in accordance with the requirements set out in chapter 14;
 - (b) a minimum of 1 2-core optical fibre cable complying with G.657 Category A specifications in the ITU-T Recommendations shall be provided in the conduit designated for a non-coaxial cable system, which shall terminate into a fibre termination point with 2 sets of SC/APC connectors at one end (which may be located in the utility room or closet) and into a fibre interface point with 2 sets of SC/APC connectors located outside the strata landed dwelling-house at the other end. The 2-core optical fibre cable, SC/APC connectors, fibre termination point and fibre interface point shall be provided in accordance with the requirements set out in chapter 15; and

- (c) 1 draw rope shall be provided in the conduit designated for a telecommunication (spare) system.

6.9 Provision of internal telecommunication wiring

- 6.9.1 Every strata landed dwelling-house shall be provided, at the minimum, with –
 - (a) RG6 coaxial cable(s) of a number equal to the total number of living room(s) and bedroom(s), which shall terminate into a multi-way splitter (which may be located in the utility room or closet) at one end and into an F-type TV outlet in each of the living room(s) and bedroom(s) at the other end. The RG6 coaxial cable(s) shall be provided in accordance with the requirements set out in chapter 14;
 - (b) unshielded twisted pair cable(s) (Category 6 or better) complying with TIA 568-C specifications of a number equal to the number of bedroom(s), which shall terminate into an RJ45 patch panel (which may be located in the utility room or closet) at one end and into an RJ45 outlet in each of the bedroom(s) at the other end. The length of each unshielded twisted pair cable shall not exceed 90m; and
 - (c) unshielded twisted pair cable(s) (Category 6 or better) complying with TIA 568-C specifications of a number equal to 2 times the total number of living room(s), which shall terminate into an RJ45 patch panel (which may be located in the utility room or closet) at one end, and into 2 RJ45 outlets in each of the living room(s) at the other end. The length of each unshielded twisted pair cable shall not exceed 90m.

6.10 Provision of electrical switch socket outlet

- 6.10.1 Every strata landed dwelling-house shall be provided with a minimum of one 13A electrical switch socket outlet which shall be placed adjacent to the fibre termination point referred to in paragraph 6.8.1(b).

6.11 Provision of access to and use of the relevant space and facilities

- 6.11.1 The developer or owner of a development shall, upon reasonable notice being given by a licensee, grant the licensee access to and use of the space and facilities provided pursuant to this Code or any previous codes, for the licensee to inspect, install, maintain, repair and upgrade its installation, plant or system. For the avoidance of doubt, the developer or owner shall ensure that its own internal processes do not cause any undue delay to the grant of such access under this paragraph 6.11.1.
- 6.11.2 Without prejudice to the generality of paragraph 6.11.1, the developer or owner shall, where it installs a false ceiling obstructing or covering any access to the relevant space and facilities (e.g. cable trays), provide appropriate access panels or openings.
- 6.11.3 The obligation of the developer or owner to provide access shall include removing and/or opening any temporary or permanent structures which are

obstructing the licensee's access to the relevant space and facilities, at no cost to the licensee.

- 6.11.4 Where the developer or owner requires the licensee to submit any proposal for cabling works based on the relevant building plans, floor plans or blueprints, the developer or owner shall provide the licensee with at least one (1) set of the relevant building plans, floor plans or blueprints, at no cost to the licensee.
- 6.11.5 Where the relevant space and facilities are located at a height of more than 4m above floor level, the developer or owner shall provide the necessary means for the licensee to access such space and facilities in accordance with prevailing legislation or regulatory requirements on workplace safety and health, at no cost to the licensee. For the avoidance of doubt, this provision does not exempt any party from its relevant obligations under the prevailing legislation or regulatory requirements on workplace safety and health.
- 6.11.6 The developer or owner shall not impose any charge or rent on the licensee (e.g. administrative charges, security escort charges, reinstatement costs) or impose any additional requirements on the licensee (e.g. requiring any insurance policy or additional insurance coverage to be taken) in connection with the grant of access to and use of the space and facilities under paragraph 6.11.1. Without prejudice to the foregoing, the developer or owner may require that a licensee place a deposit in connection with any upgrading, installation or removal works to be carried out by the licensee at the relevant space and facilities, provided that such deposit meets the following requirements:
- (a) the deposit must be refundable (subject to any deductions based on reasonable criteria that have been made known to the licensee in advance);
 - (b) the deposit must be refunded to the licensee promptly after completion of the upgrading, installation or removal works; and
 - (c) the deposit must be of a reasonable amount, taking into consideration the scope of the installation works.

6.12 Relevant space and facilities to be ready 6 months prior to the date of issuance of temporary occupation permit by the relevant authority

- 6.12.1 Where the developer or owner wishes to have telecommunication services provided to the development commencing from the date of issuance of the temporary occupation permit by the relevant authority ("TOP Date"), the developer or owner shall ensure that the relevant space and facilities (e.g. main distribution frame room, lead-in pipes and cable trays) are ready for use by the licensees at least 6 months before the TOP Date.

CHAPTER 7. DEVELOPMENT CONSISTING OF 1 OR MORE MULTI-STOREY RESIDENTIAL BUILDINGS

7.1 Application of this chapter

- 7.1.1 This chapter specifies the space and facilities to be provided for a development consisting of 1 or more multi-storey residential buildings. IDA reserves the right to require any developer or owner to provide additional space and facilities, to meet the demand for telecommunication services where necessary.
- 7.1.2 If the relevant development consists of more than 1500 residential units, the developer or owner shall consult IDA on the space and facilities to be provided and comply with such requirements as may be imposed by IDA.

7.2 Provision of the main distribution frame room

- 7.2.1 A minimum of 1 main distribution frame room shall be provided in every relevant development. Where:
- (a) there is no basement level or a single basement level, the main distribution frame room shall be located on the first or second storey of the relevant development; and
 - (b) there are multiple basement levels, the main distribution frame room shall be located:
 - (i) on the first or second storey; or
 - (ii) on the uppermost basement level provided that:
 - (A) in the event of flooding in the main distribution frame room leading to an outage in the provision of telecommunication services supplied to the development, the developer or owner shall bear all costs incurred by the relevant licensee in restoring the telecommunication services in the development except that where the relevant licensee is restoring such services to the development and external properties, the developer or owner shall only be obliged to bear a reasonable proportion of such costs to the extent that such restoration affects services provided to the development;
 - (B) in the event of flooding in the main distribution frame leading to damage caused to any installation, plant or system of any licensee by the flooding, the developer or owner shall bear all costs incurred by the relevant licensee in replacing such damaged installation, plant or system of the licensee except that where such damaged installation, plant or system is also deployed by the licensee to serve external properties, the developer or owner shall only be obliged to bear a

reasonable proportion of such costs attributable to the provision of telecommunication services to the development;

- (C) in the event of flooding in the main distribution frame room leading to an outage in the provision of telecommunication services supplied to the development and/or damage caused to any licensee's installation, plant or system, the developer or owner shall:
- (I) promptly notify the residents of the development that telecommunication services may be affected as a result of such event; and
 - (II) relocate the main distribution frame room to another location in the first or second storey of the development and bear all costs in connection therewith except that where the installation, plant or system is deployed by the licensee in the main distribution frame room to serve external properties, the developer or owner shall only be obliged to bear a reasonable proportion of such costs attributable to the provision of telecommunication services to the development.

7.2.2 The size of the main distribution frame room to be provided under paragraph 7.2.1 shall be based on the total number of residential units in the relevant development, as specified in Table 7.2.2.

Table 7.2.2 Size of main distribution frame room to be provided in each relevant development

Total number of residential units in the development	Minimum floor area of the main distribution frame room (m ²)	Minimum height of the main distribution frame room (m)
2 to 10	4	3.5
11 to 20	5	
21 to 30	6	
31 to 60	8	
61 to 120	12	
121 to 200	16	
201 to 400	20	
401 to 600	30	
601 to 800	42	
801 to 1000	49	
1001 to 1500	56	

7.2.3 Where the floor area to be provided for the main distribution frame room is up to and including 6m², the minimum width of the main distribution frame room shall be 2m. The ratio of the length and width to be provided for a main distribution frame room with a floor area of greater than 6m² shall be between 1:1 and 2:1.

- 7.2.4 The developer or owner shall provide for ventilation of the main distribution frame room by way of louvres and/or exhaust fans in accordance with the requirements set out in chapter 12.
- 7.2.5 Where a relevant development consists of a total of up to 30 residential units –
- (a) 3 sets of electrical distribution panels operating on 230V, single phase, 50Hz power supply connecting to the switch socket outlets; and
 - (b) 20A isolators
- shall be provided in every main distribution frame room in accordance with paragraphs 7.2.7 and 7.2.8.
- 7.2.6 Where a relevant development consists of a total of more than 30 but up to 1500 residential units –
- (a) 3 sets of electrical distribution panels operating on 230V, single phase, 50Hz power supply connecting to switch socket outlets; and
 - (b) 30A isolators
- shall be provided in every main distribution frame room in accordance with paragraphs 7.2.7 and 7.2.8.
- 7.2.7 Every electrical distribution panel shall contain –
- (a) a 30mA residual current circuit breaker of appropriate electrical current rating and miniature circuit breakers for final circuit connections and to facilitate the installation of electrical meters;
 - (b) 2 spare 20A miniature circuit breakers; and
 - (c) a single-line diagram in each panel.
- 7.2.8 Switch socket outlets and isolators shall be provided in every main distribution frame room in accordance with the quantities specified in Table 7.2.8 which are to be distributed evenly between the 3 sets of electrical distribution panels.

Table 7.2.8 Requirements of switch socket outlets and isolators to be provided in the main distribution frame room of each relevant development

Total number of residential units in the development	Minimum number of switch socket outlets to be provided in the main distribution frame room	Minimum number of isolators to be provided in the main distribution frame room
30 or below	3 x 2-gang 13A	3 x 20A
31 to 200	3 x 2-gang 13A	3 x 30A
201 to 1500	3 x 2-gang 13A	6 x 30A

- 7.2.9 Where a standby power generator is provided in the relevant development, the power supply to the main distribution frame room shall be connected to such standby power generator.
- 7.2.10 Where a standby power generator is not provided in the relevant development, the 20A or 30A isolators (as the case may be) in the main distribution frame room shall be connected to power sockets for connection to portable power generators and equipped with a manually activated switch to effect the changeover.
- 7.2.11 Natural and/or electrical lighting shall be provided in the main distribution frame room.
- 7.2.12 A clean earth of 1Ω or less (without the use of salt) shall be provided for the exclusive use of licensees' installation, plant or system in the main distribution frame room. The clean earth shall be connected directly to:
- (i) an independent earth electrode system; and
 - (ii) the development's electrical safety earth system.
- 7.2.13 Where a relevant development consists a total of up to 120 residential units, the clean earth that is provided pursuant to paragraph 7.2.12 shall be in the form of a copper earth bar of at least 300mm in length, 8mm in width and 5mm in thickness, with screw holes that are 6mm in diameter.
- 7.2.14 Where a relevant development consists a total of more than 120 but up to 1500 residential units, the clean earth that is provided pursuant to paragraph 7.2.12 shall be in the form of a copper earth bar of at least 600mm in length, 8mm in width and 5mm in thickness, with screw holes that are 6mm in diameter.
- 7.2.15 In addition to the requirements set out in paragraphs 7.2.1 to 7.2.14, the main distribution frame room shall be provided in accordance with the requirements set out in chapter 12.

7.3 Provision of lead-in pipes, underground pipes and manholes where there is no basement in the relevant development

- 7.3.1 Continuous lead-in pipes and underground pipes shall be provided for the relevant development as follows –
- (a) the lead-in pipes shall extend from the boundary of the development to the abutting road, to a point 1 m beyond the roadside drain located immediately outside the development; and
 - (b) the underground pipes shall connect from the lead-in pipes at the boundary of the development and run to the main distribution frame room.
- 7.3.2 The number of lead-in pipes and underground pipes to be provided under paragraph 7.3.1 shall be in accordance with the quantities specified in Table 7.3.2.

Table 7.3.2 Number of lead-in pipes and underground pipes to be provided for the relevant development with no basement

Total number of residential units in the development	Minimum number of lead-in & underground pipes to be provided
≤ 60	6
61 to 200	8
201 to 400	10
401 to 600	12
601 to 800	14
801 to 1000	16
1001 to 1500	18

7.3.3 The underground pipes shall enter the main distribution frame room in accordance with the formation specified in the Table 7.3.3.

Table 7.3.3 Pipe formation in the main distribution frame room

Total number of residential units in the development	Pipe formation in the main distribution frame room
≤ 60	2 x 3
61 to 200	2 x 4
201 to 400	2 x 5
401 to 600	2 x 6
601 to 800	2 x 7
801 to 1000	2 x 8
1001 to 1500	2 x 9

7.3.4 For the purposes of paragraph 7.3.1, all lead-in pipes and underground pipes shall be made of unplasticised polyvinyl chloride (uPVC) material with a nominal diameter of 110mm and be compliant with the Singapore Standard SS:272.

7.3.5 In addition to the requirements set out in paragraphs 7.3.1 to 7.3.4, all lead-in pipes and underground pipes shall be provided in accordance with the requirements set out in chapter 11.

7.3.6 Manholes shall be provided in each relevant development as follows –

- (a) a manhole shall be constructed at every location where there is effectively an approximately 90° or sharper bend in the direction of the underground pipes; and
- (b) a minimum of 1 manhole must be provided for every 150m segment of underground pipes laid.

- 7.3.7 The type of manhole to be provided under paragraph 7.3.6 shall be in accordance with Table 7.3.7 below based on the highest number of underground pipes entering any one side of the manhole.

Table 7.3.7 Type of manhole to be provided

Highest number of underground pipes entering any one side of the manhole	Type of manhole to be provided
≤ 2	JX2
3 to 6	MX1
7 to 9	MX2
10 to 12	MX3
13 to 16	MX4
17 to 24	MX5

- 7.3.8 In addition to the requirements set out in paragraphs 7.3.6 to 7.3.7, all manholes shall be provided in accordance with the requirements set out in chapter 11.

7.4 Provision of lead-in pipes, underground pipes, manholes and cable trays where there is 1 or more basement level(s) in the development

- 7.4.1 Continuous lead-in pipes and underground pipes shall be provided for the relevant development as follows –

- (a) the lead-in pipes shall extend from the boundary of the development to the abutting road, to a point 1m beyond the roadside drain located immediately outside the development; and
- (b) the underground pipes shall connect from the lead-in pipes at the boundary of the development and run to the retaining wall of the development.

- 7.4.2 The number of lead-in pipes and underground pipes to be provided under paragraph 7.4.1 shall be in accordance with the quantities specified in Table 7.4.2 below.

Table 7.4.2 Number of lead-in pipes and underground pipes to be provided for the relevant development with 1 or more basement level(s)

Total number of residential units in the development	Minimum number of lead-in & underground pipes to be provided
≤ 60	6
61 to 200	8
201 to 400	10
401 to 600	12
601 to 800	14
801 to 1000	16
1001 to 1500	18

- 7.4.3 For the purposes of paragraph 7.4.1, all lead-in pipes and underground pipes shall be made of unplasticised polyvinyl chloride (uPVC) material with a nominal diameter of 110mm and be compliant with the Singapore Standard SS:272.
- 7.4.4 A cable duct sealing module system shall be installed at the retaining wall of the relevant development to prevent any ingress of water flowing from the underground pipes into the basement.
- 7.4.5 In addition to the requirements set out in paragraphs 7.4.1 to 7.4.4, all lead-in pipes and underground pipes shall be provided in accordance with the requirements set out in chapter 11.
- 7.4.6 Manholes shall be provided in each relevant development as follows –
- (a) a manhole shall be constructed at every location where there is effectively an approximately 90° or sharper bend in the direction of the underground pipes; and
 - (b) at the minimum, 1 manhole must be provided for every 150m segment of underground pipes laid.
- 7.4.7 The type of manhole to be provided under paragraph 7.4.6 shall be in accordance with Table 7.4.7 below based on the highest number of underground pipes entering any one side of the manhole.

Table 7.4.7 Types of manhole to be provided

Highest number of underground pipes entering any one side of the manhole	Types of manhole to be provided
≤ 2	JX2
3 to 6	MX1
7 to 9	MX2
10 to 12	MX3
13 to 16	MX4
17 to 24	MX5

- 7.4.8 In addition to the requirements set out in paragraphs 7.4.6 to 7.4.7, all manholes shall be provided in accordance with the requirements set out in chapter 11.
- 7.4.9 A minimum of 2 cable trays shall be provided from the retaining wall of the relevant development to the main distribution frame room, of which -
- (a) a minimum of 1 cable tray shall be used for non-coaxial cables; and
 - (b) a minimum of 1 cable tray shall be used for coaxial cables.
- 7.4.10 The total width of these cable trays shall cover the total cross-sectional width of the underground pipes terminating at the retaining wall.

7.5 Provision of telecommunication equipment rooms

- 7.5.1 In addition to the main distribution frame room specified in paragraph 7.2, a telecommunication equipment room shall be provided in every multi-storey residential building within a relevant development that has a total of more than 10 residential units, except where such building already houses a main distribution frame room. Where:
- (a) there is no basement level or a single basement level in the multi-storey residential building, the telecommunication equipment room shall be located on the first or second storey of the multi-storey residential building; or
 - (b) there are multiple basement levels, the telecommunication equipment room shall be located:
 - (i) on the first or second storey; or
 - (ii) on the uppermost basement level provided that:
 - (A) in the event of flooding in the telecommunication equipment room leading to an outage in the provision of telecommunication services supplied to the relevant multi-storey residential building(s), the developer or owner shall bear all costs incurred by the relevant licensee in restoring the telecommunication services except that where the

relevant licensee is restoring such services to the development and external properties, the developer or owner shall only be obliged to bear a reasonable proportion of such costs to the extent that such restoration affects services provided to the development;

- (B) in the event of flooding in the telecommunication equipment room leading to damage caused to any installation, plant or system of any licensee by the flooding, the developer or owner shall bear all costs incurred by the relevant licensee in replacing such damaged installation, plant or system of the licensee except that where such damaged installation, plant or system is also deployed by the licensee to serve external properties, the developer or owner shall only be obliged to bear a reasonable proportion of such costs attributable to the provision of telecommunication services to serve the development; and
- (C) in the event of flooding in the telecommunication equipment room leading to an outage in the provision of telecommunication services supplied to the relevant multi-storey residential building(s) and/or damage caused to any licensee's installation, plant or system, the developer or owner shall:
 - (I) promptly notify the residents of the development that telecommunication services may be affected as a result of such event; and
 - (II) relocate the telecommunication equipment room to another location in the first or second storey of the relevant multi-storey residential building(s) and bear all costs in connection therewith except that where the installation, plant or system is deployed by the licensee at the telecommunication equipment room to serve external properties, the developer or owner shall only be obliged to bear a reasonable proportion of such costs attributable to the provision of telecommunication services to the development.

- 7.5.2 The size of the telecommunication equipment room to be provided under paragraph 7.5.1 shall be based on the total number of residential units in the multi-storey residential building, as specified in Table 7.5.2.

Table 7.5.2 Sizes of the telecommunication equipment room to be provided in each multi-storey residential building

Total number of residential units in the multi-storey residential building	Minimum floor area of the telecommunication equipment room (m²)	Minimum height of the telecommunication equipment room (m)
11 to 30	4	3.5
31 to 60	5	
61 to 120	6	
121 to 300	8	
301 to 600	10	

- 7.5.3 Where the floor area to be provided for the telecommunication equipment room is up to and including 6m², the minimum width of the telecommunication equipment room shall be 2m. The ratio of the length and width to be provided for a telecommunication equipment room with a floor area of 8m² or greater shall be between 1:1 and 2:1.

- 7.5.4 Where:

- (a) there is no basement level in the multi-storey residential building, the developer or owner shall provide underground pipes for each telecommunication equipment room in accordance with paragraphs 7.5.5, 7.5.6 and 7.5.8; and
- (b) there is 1 or more basement level(s) in the multi-storey residential building, the developer or owner shall provide:
 - (i) underground pipes for each telecommunication equipment room in accordance with paragraphs 7.5.5, 7.5.6 and 7.5.8; or
 - (ii) a minimum of 2 cable trays for each telecommunication equipment room in accordance with paragraphs 7.5.9 and 7.5.10.

- 7.5.5 The underground pipes referred to in paragraph 7.5.4 shall be in accordance with the quantities specified in Table 7.5.5 below.

Table 7.5.5 Number of underground pipes to be provided for the telecommunication equipment room

Total number of residential units in the multi-storey building	Minimum number of underground pipes to be provided
11 to 60	6
61 to 200	8
201 to 400	10
401 to 600	12

- 7.5.6 When entering the telecommunication equipment room, the underground pipes referred to in paragraph 7.5.5 shall be configured in accordance with the formation specified in Table 7.5.6.

Table 7.5.6 Pipe formation in the telecommunication equipment room

Total number of residential units in the in the multi-storey residential building	Pipe formation in the telecommunication equipment room
11 to 60	2 x 3
61 – 200	2 x 4
201 – 400	2 x 5
401 – 600	2 x 6

- 7.5.7 The developer or owner may consult IDA on the number of underground pipes to be provided between the main distribution frame room and the telecommunication equipment room (save for underground pipes to be provided for each telecommunication equipment room which shall be provided in accordance with paragraph 7.5.5), and shall comply with such requirements as may be imposed by IDA.
- 7.5.8 For the purposes of paragraph 7.5, all underground pipes shall be made of unplasticised polyvinyl chloride (uPVC) material with a nominal diameter of 110mm and be compliant with the Singapore Standard SS:272.
- 7.5.9 The cable trays referred to in paragraph 7.5.4 shall include –
- (a) a minimum of 1 cable tray which shall be used for non-coaxial cables; and
 - (b) a minimum of 1 cable tray which shall be used for coaxial cables.
- 7.5.10 The developer or owner may consult IDA on the size of cable trays to be provided between the main distribution frame room and the telecommunication equipment room, and shall comply with such requirements as may be imposed by IDA.
- 7.5.11 The developer or owner shall provide for ventilation of the telecommunication equipment room by way of louvres and/or exhaust fans in accordance with the requirements set out in chapter 12.

- 7.5.12 3 sets of electrical distribution panels operating on 230V, single phase, 50Hz power supply connecting to the switch socket outlets shall be provided in the telecommunication equipment room in accordance with paragraphs 7.5.13 and 7.5.14.
- 7.5.13 Every electrical distribution panel shall contain –
- (a) a 30mA residual current circuit breaker of appropriate electrical current rating and miniature circuit breakers for final circuit connections and to facilitate the installation of electrical meters;
 - (b) 2 spare 20A miniature circuit breakers; and
 - (c) a single-line diagram in each panel.
- 7.5.14 Three (3) 2-gang 13A switch socket outlets and three (3) 20A isolators shall be provided in the telecommunication equipment room which are to be distributed evenly between the 3 sets of electrical distribution panels.
- 7.5.15 Where a standby power generator is provided in the relevant development, the power supply to the telecommunication equipment room shall be connected to such standby power generator.
- 7.5.16 Natural and/or electrical lighting shall be provided in the telecommunication equipment room.
- 7.5.17 A clean earth of 1Ω or less (without the use of salt) shall be provided for the exclusive use of licensees' installation, plant or system in the telecommunication equipment room. The clean earth shall be connected directly to:
- (a) an independent earth electrode system; and
 - (b) the development's electrical safety earth system.
- 7.5.18 The clean earth that is provided pursuant to paragraph 7.5.17 shall be in the form of a copper earth bar of at least 300mm in length, 8mm in width and 5mm in thickness, with screw holes that are 6 mm in diameter.
- 7.5.19 In addition to the requirements set out in paragraphs 7.5.1 to 7.5.18, the telecommunication equipment room shall be provided in accordance with the requirements set out in chapter 12.

7.6 Provision of the telecommunication risers

- 7.6.1 Telecommunication risers shall be provided in every residential multi-storey building in the relevant development.
- 7.6.2 The serving radius of each telecommunication riser shall not exceed 40m. Each telecommunication riser shall be labelled as "Telecom Riser" and numbered for easy reference and identification.

- 7.6.3 All telecommunication riser shafts must be constructed in a direct vertical line throughout the building.
- 7.6.4 The dimensions of each telecommunication riser to be provided under paragraph 7.6.1 shall be based on the total number of residential units to be served by the telecommunication riser, as specified in Table 7.6.4.

Table 7.6.4 Dimensions of the telecommunication riser

Total number of residential units served by a telecommunication riser	Minimum dimensions of each telecommunication riser
≤ 30	600 mm (width) x 450 mm (depth)
> 30	800 mm (width) x 600 mm (depth)

- 7.6.5 Every telecommunication riser shall have a door which can be fully opened outwards throughout its entire width for easy access at each floor level. The height of the door shall be at least 2.1m. The width of the door shall be in accordance with the dimensions specified in Table 7.6.5 below.

Table 7.6.5 Minimum width of door of the telecommunication riser

Minimum dimensions of each telecommunication riser	Minimum width of each door of the telecommunication riser
600 mm (width) x 450 mm (depth)	500 mm
800 mm (width) x 600 mm (depth)	600 mm

- 7.6.6 All doors of the telecommunication risers shall be locked.
- 7.6.7 A minimum of 2 cable trays shall be provided in each telecommunication riser from the first storey or basement to the topmost level of every multi-storey residential building, of which -
- (a) a minimum of 1 cable tray shall be used for non-coaxial cables; and
 - (b) a minimum of 1 cable tray shall be used for coaxial cables.
- 7.6.8 The cable trays for non-coaxial cables and coaxial cables shall be installed opposite each other on the side wall of the telecommunication riser.
- 7.6.9 For the purposes of paragraph 7.6.7, cable trays shall be provided in accordance with the requirements specified in Table 7.6.9.

Table 7.6.9 Width of cable trays in each telecommunication riser

	Minimum width of each cable tray where the telecommunication riser has a side wall depth of 450 mm	Minimum width of each cable tray where the telecommunication riser has a side wall depth of 600 mm
Cable tray for buildings up to and including 25 storeys	200 mm	300 mm
Cable tray for buildings more than 25 storeys and up to and including 50 storeys	300 mm	400 mm
Cable tray for buildings more than 50 storeys	To consult IDA	To consult IDA

7.6.10 The telecommunication riser openings on every storey in each multi-storey residential building shall be sealed in accordance with the Code of Practice for Fire Precautions in Buildings issued by Singapore Civil Defence Force.

7.6.11 In addition to the requirements set out in paragraphs 7.6.1 to 7.6.10, all telecommunication risers shall be provided in accordance with the requirements set out in chapter 13.

7.7 Provision of cable trays from the main distribution frame room or telecommunication equipment room to each telecommunication riser

7.7.1 A minimum of 2 cable trays shall be provided from the main distribution frame room or telecommunication equipment room of each building to each telecommunication riser, of which –

- (a) a minimum of 1 cable tray shall be used for non-coaxial cables; and
- (b) a minimum of 1 cable tray shall be used for coaxial cables

in accordance with the requirements specified in Table 7.7.1.

Table 7.7.1 Width of cable trays to be provided from the main distribution frame room or telecommunication equipment room to each telecommunication riser

	Minimum width of each cable tray where the telecommunication riser serves ≤ 30 residential units	Minimum width of each cable tray where the telecommunication riser serves > 30 residential units
Cable tray (whether for non-coaxial cables or coaxial cables)	300 mm	400 mm

7.8 Provision of a broadband coaxial cable system

- 7.8.1 A broadband coaxial cable system shall be provided from the main distribution frame room to each residential unit in the development. The broadband coaxial cable system shall be provided in accordance with chapter 14.

7.9 Provision of conduits from the telecommunication risers to each residential unit

- 7.9.1 Every residential unit in the relevant development shall be provided, at the minimum, with –
- (a) 1 conduit of a minimum size of 20mm in diameter for a telecommunication (non-coaxial cable) system which shall run from the telecommunication riser into the residential unit, and terminating into the utility room or closet;
 - (b) 1 conduit of a minimum size of 20mm in diameter for a telecommunication (coaxial cable) system which shall run from the telecommunication riser into the residential unit, and terminating into the utility room or closet; and
 - (c) 1 conduit of a minimum size of 20mm in diameter for a telecommunication (spare) system which shall run from the telecommunication riser into the residential unit, and terminating into the utility room or closet.

7.10 Provision of cables in the conduits

- 7.10.1 With regard to the conduits referred to in paragraph 7.9.1 –
- (a) a minimum of 1 coaxial cable shall be provided in the conduit designated for a broadband coaxial cable system, which shall terminate into a multi-way splitter at one end (which may be located in the utility room or closet) and into a tap or splitter box of the main coaxial cable in the telecommunication riser at the other end. The coaxial cable shall be provided in accordance with the requirements set out in chapter 14;
 - (b) a minimum of 1 2-core optical fibre cable complying with G.657 Category A specifications in the ITU-T Recommendations shall be provided in the conduit designated for a non-coaxial cable system, which shall terminate into a fibre termination point with 2 sets of SC/APC connectors at one end (which may be located in the utility room or closet) and into a fibre interface point with 2 sets of SC/APC connectors located in the telecommunication riser at the other end. The 2-core optical fibre cable, SC/APC connectors, fibre termination point and fibre interface point shall be provided in accordance with the requirements set out in chapter 15; and
 - (c) 1 draw rope shall be provided in the conduit designated for a telecommunication (spare) system.

7.11 Provision of internal telecommunication wiring

7.11.1 Every residential unit shall be provided, at the minimum, with –

- (a) RG6 coaxial cable(s) of a number equal to the total number of living room(s) and bedroom(s), which shall terminate into a multi-way splitter (which may be located in the utility room or closet) at one end and into an F-type TV outlet in each of the living room(s) and bedroom(s) at the other end. The RG6 coaxial cable(s) shall be provided in accordance with the requirements set out in chapter 14;
- (b) unshielded twisted pair cable(s) (Category 6 or better) complying with TIA 568-C specifications of a number equal to the number of bedroom(s), which shall terminate into an RJ45 patch panel (which may be located in the utility room or closet) at one end and an RJ45 outlet in each of the bedroom(s) at the other end. The length of each unshielded twisted pair cable shall not exceed 90m; and
- (c) unshielded twisted pair cable(s) (Category 6 or better) complying with TIA 568-C specifications of a number equal to two times the total number of living room(s), which shall terminate into an RJ45 patch panel (which may be located in the utility room or closet) at one end, and into 2 RJ45 outlets in each of the living room(s) at the other end. The length of each unshielded twisted pair cable shall not exceed 90m.

7.12 Provision of electrical switch socket outlet

7.12.1 Every residential unit shall be provided with a minimum of one 13A electrical switch socket outlet which shall be placed adjacent to the fibre termination point referred to in paragraph 7.10.1(b).

7.13 Provision of mobile deployment space

7.13.1 If the relevant development consists of 80 or more residential units, the developer or owner shall, where required and notified by any mobile telecommunication licensee, provide within a reasonable time, mobile deployment space in accordance with the dimensions specified in Table 7.13.1 based on the total number of residential units in the development. If the relevant development consists of more than 1500 residential units, the developer or owner shall consult IDA on the mobile deployment space to be provided and comply with such requirements as may be imposed by IDA.

Table 7.13.1 Mobile deployment space to be provided in each relevant development

Total number of residential units in the development	Mobile deployment space (m ²)		Minimum height of mobile deployment space(m)
	Where the mobile deployment space is provided as a single space	Where the mobile deployment space is provided as two or more separate spaces	
80 to 200	18	24*	3
201 to 600	36*		
601 to 1500	54*		
> 1500	To consult IDA		

* Size of each disaggregated MDS shall be at least 8m²

7.13.2 The developer or owner may locate the mobile deployment space to be provided under paragraph 7.13.1 at any unused space in the development (e.g. carpark and roof top), subject to the additional requirements provided in paragraphs 7.13.3 to 7.13.4 and chapter 12. For the avoidance of doubt, the mobile deployment space shall not be located in the main distribution frame room or the telecommunication equipment room, unless there is sufficient space available after having fulfilled the space requirements of the main distribution frame room or telecommunication equipment room and there is a clear demarcation of the space designated as mobile deployment space.

7.13.3 Where:

- (a) there is no basement level or a single basement level, the mobile deployment space shall be located on the first or higher storey of the relevant development; and
- (b) there are multiple basement levels, the mobile deployment space shall be located:
 - (i) on the first or higher storey; or
 - (ii) on the uppermost basement level provided that:
 - (A) in the event of flooding in the mobile deployment space leading to an outage in the provision of public cellular mobile telecommunication services supplied to the development, the developer or owner shall bear all costs incurred by the relevant licensee in restoring the public cellular mobile telecommunication services in the development except that where the relevant licensee is restoring such services to the development and external properties, the developer or owner shall only be obliged to bear a reasonable proportion of such costs attributable to the provision of public cellular mobile telecommunication services to the development;
 - (B) in the event of flooding in the mobile deployment space leading to damage caused to any installation, plant or system of any licensee by the flooding, the developer or owner shall bear all costs incurred by the relevant licensee in replacing such damaged installation, plant or system of

the licensee except that where such damaged installation, plant or system is also deployed by the licensee to serve external properties, the developer or owner shall only be obliged to bear a reasonable proportion of such costs attributable to the provision of public cellular mobile telecommunication services to the development;

- (C) in the event of flooding in the mobile deployment space leading to an outage in the provision of public cellular mobile telecommunication services supplied to the development and/or damage caused to any licensee's installation, plant or system, the developer or owner shall:
 - (I) promptly notify the residents of the development that public cellular mobile telecommunication services may be affected as a result of such event; and
 - (II) relocate the mobile deployment space to another location in the first or higher storey of the development and bear all costs in connection therewith except that where the installation, plant or system is also deployed by the licensee at the mobile deployment space to serve external properties, the developer or owner shall only be obliged to bear a reasonable proportion of such costs attributable to the provision of public cellular mobile telecommunication services to the development.

- 7.13.4 Where the relevant development comprises 1 or more buildings, any of which has 30 or more storeys, the developer or owner shall provide the mobile deployment space in 2 or more separate spaces, provided that the total space provided meets the relevant mobile deployment space and each separate space is at least 8m² with a minimum width of at least 2m. In determining the location of such spaces, the developer or owner shall locate them so as to facilitate the provision of public cellular mobile telecommunication services to the whole development.
- 7.13.5 Subject to paragraph 7.13.4, the developer or owner may provide the mobile deployment space in one or more separate spaces, provided that the total space meets the relevant mobile deployment space and each separate space is at least 8m² with a minimum width of at least 2m.
- 7.13.6 The developer or owner shall, at its own cost, comply with any legislation or regulatory requirements in connection with the provision of the mobile deployment space (e.g. obtaining the relevant approvals for conversion of car park lots to mobile deployment space, or installation of fencing or trellis).
- 7.13.7 Where the licensee wishes to install any facilities (e.g. cable trays and power points) required to serve its installation, plant or system at the mobile deployment space, the developer or owner shall provide reasonable assistance to facilitate such installation by the licensee.

- 7.13.8 If the developer or owner wishes to arrange for telecommunication mobile coverage for the relevant development prior to the date of issue of the temporary occupation permit, the developer or owner may refer to chapter 4 of the Guidelines for Info-communication Facilities in Buildings.

7.14 Provision of access to and use of the relevant space and facilities

- 7.14.1 The developer or owner of a development shall, upon reasonable notice being given by a licensee, grant the licensee access to and use of the space and facilities provided pursuant to this Code or any previous codes, for the licensee to inspect, install, maintain, repair and upgrade its installation, plant or system. For the avoidance of doubt, the developer or owner shall ensure that its own internal processes do not cause any undue delay to the grant of such access under this paragraph 7.14.1.
- 7.14.2 Without prejudice to the generality of paragraph 7.14.1, the developer or owner shall, where it installs a false ceiling obstructing or covering any access to the relevant space and facilities (e.g. cable trays), provide appropriate access panels or openings.
- 7.14.3 The obligation of the developer or owner to provide access shall include removing and/or opening any temporary or permanent structures which are obstructing the licensee's access to the relevant space and facilities, at no cost to the licensee.
- 7.14.4 Where the developer or owner requires the licensee to submit any proposal for cabling works based on the relevant building plans, floor plans or blueprints, the developer or owner shall provide the licensee with at least one (1) set of the relevant building plans, floor plans or blueprints, at no cost to the licensee.
- 7.14.5 Where the relevant space and facilities are located at a height of more than 4m above floor level, the developer or owner shall provide the necessary means for the licensee to access such space and facilities in accordance with prevailing legislation or regulatory requirements on workplace safety and health, at no cost to the licensee. For the avoidance of doubt, this provision does not exempt any party from its relevant obligations under the prevailing legislation or regulatory requirements on workplace safety and health.
- 7.14.6 The developer or owner shall not impose any charge or rent on the licensee (e.g. administrative charges, security escort charges, reinstatement costs) or impose any additional requirements on the licensee (e.g. requiring any insurance policy or additional insurance coverage to be taken) in connection with the grant of access to and use of the space and facilities under paragraph 7.14.1. Without prejudice to the foregoing, the developer or owner may require that a licensee place a deposit in connection with any upgrading, installation or removal works to be carried out by the licensee at the relevant space and facilities, provided that such deposit meets the following requirements:
- (a) the deposit must be refundable (subject to any deductions based on reasonable criteria that have been made known to the licensee in advance);

- (b) the deposit must be refunded to the licensee promptly after completion of the upgrading, installation or removal works; and
- (c) the deposit must be of a reasonable amount, taking into consideration the scope of the installation works.

7.15 Relevant space and facilities to be ready 6 months prior to the date of issuance of temporary occupation permit by the relevant authority

- 7.15.1 Where the developer or owner wishes to have telecommunications services (including public cellular mobile telecommunication services) provided to the development starting from the date of issuance of the temporary occupation permit by the relevant authority (“TOP Date”), the developer or owner shall ensure that the relevant space and facilities (e.g. mobile deployment space, main distribution frame room, telecommunications risers and lead-in pipes) are ready for use by the licensees at least 6 months before the TOP Date.

CHAPTER 8. DEVELOPMENT CONSISTING OF 1 OR MORE NON-RESIDENTIAL BUILDINGS OF A TOTAL USABLE FLOOR AREA OF MORE THAN 2,000m²

8.1 Application of this chapter

8.1.1 This chapter specifies the space and facilities to be provided for a development, consisting of 1 or more non-residential buildings, with a total usable floor area of more than 2,000m². IDA reserves the right to require any developer or owner to provide additional space and facilities, to meet the demand for telecommunication services where necessary.

8.1.2 If a relevant development consists of a total usable floor area of more than 200,000m², the developer or owner shall consult IDA on the space and facilities to be provided and comply with such requirements as may be imposed by IDA.

8.2 Provision of the main distribution frame room

8.2.1 A minimum of 1 main distribution frame room shall be provided in every relevant development. Where:

- (a) there is no basement level or a single basement level, the main distribution frame room shall be located on the first or second storey of the relevant development; and
- (b) there are multiple basement levels, the main distribution frame room shall be located:
 - (i) on the first or second storey; or
 - (ii) on the uppermost basement level provided that:
 - (A) in the event of flooding in the main distribution frame room leading to an outage in the provision of telecommunication services supplied to the development, the developer or owner shall bear all costs incurred by the relevant licensee in restoring the telecommunication services in the development except that where the relevant licensee is restoring such services to the development and external properties, the developer or owner shall only be obliged to bear a reasonable proportion of such costs attributable to the provision of telecommunication services to the development;
 - (B) in the event of flooding in the main distribution frame leading to damage caused to any installation, plant or system of any licensee by the flooding, the developer or owner shall bear all costs incurred by the relevant licensee in replacing such damaged installation, plant or system of the licensee except that where such damaged installation, plant or system is also deployed by the licensee to serve external properties,

the developer or owner shall only be obliged to bear a reasonable proportion of such costs attributable to the provision of telecommunication services to the development; and

- (C) in the event of flooding in the main distribution frame room leading to an outage in the provision of telecommunication services supplied to the development and/or damage caused to any licensee's installation, plant or system, the developer or owner shall:
- (I) promptly notify the tenants of the development that telecommunication services may be affected as a result of such event; and
 - (II) relocate the main distribution frame room to another location in the first or second storey of the development and bear all costs in connection therewith except that where the installation, plant or system is also deployed by the licensee at the main distribution frame room to serve external properties, the developer or owner shall only be obliged to bear a reasonable proportion of such costs attributable to the provision of telecommunication services to the development.

8.2.2 The size of the main distribution frame room to be provided under paragraph 8.2.1 shall be based on the total usable floor area of the non-residential building in the relevant development, as specified in Table 8.2.2.

Table 8.2.2 Total size of main distribution frame room to be provided in each relevant development

Total usable floor area in the development ('000 m ²)	Minimum total floor area of the main distribution frame room (m ²)	Minimum height of the main distribution frame room (m)
> 2 to 5	12	3.5
> 5 to 12	20	
> 12 to 25	30	
> 25 to 50	40	
> 50 to 75	60	
> 75 to 100	80	
> 100 to 125	100	
> 125 to 150	120	
> 150 to 175	140	
> 175 to 200	160	

8.2.3 Where the usable floor area of the relevant development exceeds 50,000m², 2 or more main distribution frame room shall be provided to facilitate cable distribution by licensees. The total combined size of the main distribution frame rooms shall be no less than the minimum size specified in Table 8.2.2 based on the relevant usable floor area, and each main distribution frame room shall be no smaller than 12m².

- 8.2.4 The developer or owner shall, in accordance with the requirements set out in chapter 12, provide for ventilation of the main distribution frame room by way of:
- (a) air-conditioning from the central system (where central air-conditioning system is provided in the relevant development); or
 - (b) louvres and/or exhaust fans.
- 8.2.5 3 sets of electrical distribution panels operating on 230V, single phase, 50Hz power supply connecting to switch socket outlets and isolators shall be provided in the main distribution frame room in accordance with paragraphs 8.2.6 and 8.2.7.
- 8.2.6 Every electrical distribution panel shall contain –
- (a) a 30mA residual current circuit breaker of appropriate electrical current rating and miniature circuit breakers for final circuit connections and to facilitate the installation of electrical meters;
 - (b) 2 spare 20A miniature circuit breakers; and
 - (c) a single-line diagram in each panel.
- 8.2.7 Switch socket outlets and isolators shall be provided in every main distribution frame room in accordance with the quantities specified in Table 8.2.7 which are to be distributed evenly between the 3 sets of electrical distribution panels.

Table 8.2.7 Requirements of switch socket outlets and isolators for every main distribution frame room in each relevant development

Size of main distribution frame room (m²)	Minimum number of switch socket outlets to be provided in the main distribution frame room	Minimum number of isolators to be provided in the main distribution frame room
≤ 30	3 x 2-gang 13A	6 x 30A
> 30	3 x 2-gang 13A	9 x 30A

- 8.2.8 Where a standby power generator is provided in the relevant development, the power supply to the main distribution frame room shall be connected to such standby power generator.
- 8.2.9 Where a standby power generator is not provided in the relevant development, the 30A isolators in the main distribution frame room shall be connected to power sockets for connection to portable power generators and equipped with a manually activated switch to effect the changeover.
- 8.2.10 Natural and/or electrical lighting shall be provided in the main distribution frame room.

- 8.2.11 A clean earth of 1Ω or less (without the use of salt) shall be provided for the exclusive use of licensees' installation or plant in the main distribution frame room. The clean earth shall be connected directly to:
- (a) an independent earth electrode system; and
 - (b) the development's electrical safety earth system.
- 8.2.12 Where the usable floor area of the development served by a main distribution frame room is less than or equal to $25,000\text{m}^2$, the clean earth that is provided pursuant to paragraph 8.2.11 shall be in the form of a copper earth bar of at least 300mm in length, 8mm in width and 5mm in thickness, with screw holes that are 6mm in diameter.
- 8.2.13 Where the usable floor area of the development served by a main distribution frame room is more than $25,000\text{m}^2$, the clean earth that is provided pursuant to paragraph 8.2.11 shall be in the form of a copper earth bar of at least 600mm in length, 8mm in width and 5mm in thickness, with screw holes that are 6mm in diameter.
- 8.2.14 In addition to the requirements set out in paragraphs 8.2.1 to 8.2.13, the main distribution frame room shall be provided in accordance with the requirements set out in chapter 12.

8.3 Provision of lead-in pipes, underground pipes and manholes where there is no basement in the development

- 8.3.1 Continuous lead-in pipes and underground pipes shall be provided for the relevant development as follows –
- (a) the lead-in pipes shall extend from the boundary of the development to the abutting road, to a point 1m beyond the roadside drain located immediately outside the development; and
 - (b) the underground pipes shall connect to the lead-in pipes at the boundary of the development and run to the main distribution frame room.
- 8.3.2 The number of lead-in pipes and underground pipes to be provided under paragraph 8.3.1 shall be in accordance with the quantities specified in Table 8.3.2.

Table 8.3.2 Number of lead-in pipes and underground pipes to be provided for relevant development with no basement

Size of the main distribution frame room (m²)	Minimum number of lead-in & underground pipes to be provided
< 30	8
30 to < 40	10
40 to < 60	14
60 to < 80	20
80 to < 100	24
100 to < 120	28
120 to < 140	32
140 to <160	40
≥ 160	48

8.3.3 The underground pipes shall enter the main distribution frame room in accordance with the formation specified in Table 8.3.3.

Table 8.3.3 Pipe formation in the main distribution frame room

Size of the main distribution frame room (m²)	Pipe formation in the main distribution frame room
< 30	2 x 4
30 to < 40	2 x 5
40 to < 60	2 x 7
60 to < 80	2 sets of 2 x 5
80 to < 100	2 sets of 2 x 6
100 to < 120	2 sets of 2 x 7
120 to < 140	2 sets of 2 x 8
140 to <160	2 sets of 2 x 10
≥ 160	2 sets of 2 x 12

8.3.4 Where the size of the main distribution frame room is 60m² or more, the 2 sets of underground pipes to be provided in accordance with paragraph 8.3.3 shall enter the main distribution frame room in different directions.

8.3.5 For the purposes of paragraph 8.3.1, all lead-in pipes and underground pipes shall be made of unplasticised polyvinyl chloride (uPVC) material with a nominal diameter of 110mm and be compliant with the Singapore Standard SS:272.

8.3.6 In addition to the requirements set out in paragraphs 8.3.1 to 8.3.5, all lead-in pipes and underground pipes shall be provided in accordance with the requirements set out in chapter 11.

8.3.7 Manholes shall be provided in each relevant development as follows –

- (a) a manhole shall be constructed at every location where there is effectively an approximately 90° or sharper bend in the direction of the underground pipes; and
- (b) a minimum of 1 manhole must be provided for every 150m segment of underground pipes laid.

8.3.8 The types of manhole to be provided under paragraph 8.3.7 shall be in accordance with Table 8.3.8 based on the highest number of underground pipes entering any one side of the manhole.

Table 8.3.8 Types of manhole to be provided

Highest number of underground pipes entering any one side of the manhole	Types of manhole to be provided
≤ 2	JX2
3 to 6	MX1
7 to 9	MX2
10 to 12	MX3
13 to 16	MX4
17 to 24	MX5

8.3.9 In addition to the requirements set out in paragraphs 8.3.7 to 8.3.8, all manholes shall be provided in accordance with the requirements set out in chapter 11.

8.4 Provision of lead-in pipes, underground pipes, manholes and cable trays where there is a basement in the development

8.4.1 Continuous lead-in pipes and underground pipes shall be provided for the relevant development as follows –

- (a) the lead-in pipes shall extend from the boundary of the development to the abutting road, to a point 1m beyond the roadside drain located immediately outside the development; and
- (b) the underground pipes shall connect from the lead-in pipes at the boundary of the development and run to the retaining wall of the development.

8.4.2 The number of lead-in pipes and underground pipes to be provided under paragraph 8.4.1 shall be in accordance with the quantities specified in Table 8.4.2.

Table 8.4.2 Number of lead-in pipes and underground pipes to be provided for relevant development with basement

Size of the main distribution frame room (m²)	Minimum number of lead-in & underground pipes to be provided
< 30	8
30 to < 40	10
40 to < 60	14
60 to < 80	20
80 to < 100	24
100 to < 120	28
120 to < 140	32
140 to <160	40
≥ 160	48

- 8.4.3 Where the size of the main distribution frame room is 60m² or more, half of the underground pipes that run to the retaining wall of the development shall enter the basement from a different direction.
- 8.4.4 For the purposes of paragraph 8.4.1, all lead-in pipes and underground pipes shall be made of unplasticised polyvinyl chloride (uPVC) material with a nominal diameter of 110mm and be compliant with the Singapore Standard SS:272.
- 8.4.5 A cable duct sealing module system shall be installed at the retaining wall of the development to prevent any ingress of water flowing from the underground pipes into the basement.
- 8.4.6 In addition to the requirements set out in paragraphs 8.4.1 to 8.4.5, all lead-in pipes and underground pipes shall be provided in accordance with the requirements set out in chapter 11.
- 8.4.7 Manholes shall be provided in each relevant development as follows –
- (a) a manhole shall be constructed at every location where there is effectively an approximately 90° or sharper bend in the direction of the underground pipes; and
 - (b) a minimum of 1 manhole must be provided for every 150m segment of underground pipes laid.
- 8.4.8 The type of manholes to be provided under paragraph 8.4.7 shall be in accordance with Table 8.4.8 based on the highest number of underground pipes entering any one side of the manhole.

Table 8.4.8 Types of manhole to be provided

Highest number of underground pipes entering any one side of the manhole	Types of manhole to be provided
≤ 2	JX2
3 to 6	MX1
7 to 9	MX2
10 to 12	MX3
13 to 16	MX4
17 to 24	MX5

- 8.4.9 In addition to the requirements set out in paragraphs 8.4.7 to 8.4.8, all manholes shall be provided in accordance with the requirements set out in chapter 11.
- 8.4.10 A minimum of 2 cable trays shall be provided from the retaining wall of the development to each main distribution frame room, of which -
- (a) a minimum of 1 cable tray shall be used for non-coaxial cables; and
 - (b) a minimum of 1 cable tray shall be used for coaxial cables.
- 8.4.11 The total width of these cable trays shall cover the total cross-sectional width of the underground pipes terminating at the retaining wall.
- 8.4.12 Where additional main distribution frame rooms are provided, the developer or owner shall consult IDA on the quantity and size of cable trays to be provided between each main distribution frame room, and comply with such requirements as may be imposed by IDA.

8.5 Provision of telecommunication risers

- 8.5.1 Telecommunication risers shall be provided in every non-residential building in the relevant development.
- 8.5.2 The serving radius of each telecommunication riser shall not exceed 40m. Each telecommunication riser shall be labelled as "Telecom Riser" and numbered for easy reference and identification.
- 8.5.3 All telecommunication riser shafts must be constructed in a direct vertical line throughout the building.
- 8.5.4 The dimensions of each telecommunication riser to be provided under paragraph 8.5.1 shall be based on the usable floor area of the non-residential building, as specified in Table 8.5.4.

Table 8.5.4 Dimensions of the telecommunication riser

Total usable floor area of the building (per '000 m ²)	Minimum dimensions of the telecommunication riser
≤ 75	1100 mm (width) x 800 mm (depth)
> 75	1600 mm (width) x 800 mm (depth)

8.5.5 Every telecommunication riser shall have a door which can be fully opened outwards throughout its entire width for easy access at each floor level. The height of the door shall be at least 2.1 m. The width of the door shall be in accordance with the dimensions specified in Table 8.5.5 below.

Table 8.5.5 Minimum width of door of the telecommunication riser

Minimum dimensions of the telecommunication riser	Minimum width of door of the telecommunication riser
1100mm (width) x 800mm (depth)	900mm
1600mm (width) x 800mm (depth)	Double leaf door of total minimum width of 1400mm

8.5.6 All doors of the telecommunication risers shall be locked.

8.5.7 A minimum of 2 cable trays shall be provided in each telecommunication riser from the bottommost level to the topmost level of every non-residential building, of which -

- (a) a minimum of 1 cable tray shall be used for non-coaxial cables; and
- (b) a minimum of 1 cable tray shall be used for coaxial cables.

8.5.8 The cable trays for non-coaxial cables and coaxial cables shall be installed opposite each other on the side walls of the telecommunication riser.

8.5.9 For the purposes of paragraph 8.5.7, cable trays shall be provided in accordance with the requirements specified in Table 8.5.9.

Table 8.5.9 Width of cable trays in each telecommunication riser

	Minimum width of each cable tray where the building has up to and including 25 storeys	Minimum width of cable trays where the building has more than 25 storeys
Cable trays (whether for non-coaxial cables or coaxial cables)	450 mm	600 mm

8.5.10 The telecommunication riser openings on every storey in each non-residential building shall be sealed in accordance with the Code of Practice for Fire Precautions in Buildings issued by Singapore Civil Defence Force.

8.5.11 In addition to the requirements set out in paragraphs 8.5.1 to 8.5.10, all telecommunication risers shall be provided in accordance with the requirements set out in chapter 13.

8.6 Provision of cable trays from the main distribution frame room to each telecommunication riser

8.6.1 A minimum of 2 cable trays with a width of 600mm each shall be provided from the main distribution frame room to each telecommunication riser, of which –

- (a) a minimum of 1 cable tray shall be used for non-coaxial cables; and
- (b) a minimum of 1 cable tray shall be used for coaxial cables.

8.6.2 Slots of a minimum height of 300mm shall be provided in the wall of each telecommunication riser for cable trays to pass through.

8.7 Provision of a cable distribution system from the telecommunication riser to each non-residential unit

8.7.1 A cable distribution system shall be provided to facilitate the laying of non-coaxial cables and coaxial cables from the telecommunication riser to each non-residential unit. The developer or owner may select an appropriate cable distribution system as described in the Guidelines for Info-communications Facilities in Buildings for the development.

8.8 Provision of mobile deployment space

8.8.1 If the relevant development consists of 1 or more non-residential buildings with a total mobile coverage area of more than 2,000m², the developer or owner shall, where required and notified by any mobile telecommunication licensee, provide within a reasonable time, mobile deployment space in accordance with the dimensions as specified in Table 8.8.1 based on the mobile coverage area in the development. If the relevant development consists of a total mobile coverage area of more than 200,000m², the developer or owner shall consult IDA on the mobile deployment space to be provided and comply with such requirements as may be imposed by IDA.

Table 8.8.1 Mobile deployment space to be provided in each relevant development

Total mobile coverage area ('000 m ²)	Mobile deployment space (m ²)		Minimum height of mobile deployment space (m)
	Where the mobile deployment space is provided as a single space	Where the mobile deployment space is provided as two or more separate spaces	
> 2 to ≤ 6	18	24*	3
> 6 to ≤ 20	36*		
> 20 to ≤ 100	54*		
> 100 to ≤ 200	72*		
> 200	To consult IDA		

* Size of each disaggregated MDS shall be at least 8m²

- 8.8.2 The developer or owner of an underground MRT station or facility building (associated with a road tunnel) shall be deemed to have satisfied the requirements set out in paragraph 8.8.1 in relation to such underground MRT station or facility building where the developer or owner has already provided mobile deployment space in accordance with paragraphs 10.2 and 10.3 of chapter 10.
- 8.8.3 The developer or owner may locate the mobile deployment space to be provided under paragraph 8.8.1 at any unused space in the development (e.g. carpark and roof top), subject to the additional requirements provided in paragraphs 8.8.4 to 8.8.5 and chapter 12. For the avoidance of doubt, the mobile deployment space shall not be located in the main distribution frame room, unless there is sufficient space available after having fulfilled the space requirements of the main distribution frame room and there is a clear demarcation of the space designated as mobile deployment space.
- 8.8.4 Where:
- (a) there is no basement level or a single basement level, the mobile deployment space shall be located on the first or higher storey of the relevant development; and
 - (b) there are multiple basement levels, the mobile deployment space shall be located:
 - (i) on the first or higher storey; or
 - (ii) on the uppermost basement level provided that:
 - (A) in the event of flooding in the mobile deployment space leading to an outage in the provision of public cellular mobile telecommunication services supplied to the development, the developer or owner shall bear all costs incurred by the relevant licensee in restoring the public cellular mobile telecommunication services in the development except that where the relevant licensee is restoring such services to the development and external properties, the developer or owner shall only be obliged to bear a reasonable proportion of such costs attributable to the provision of public cellular mobile telecommunication services to the development;
 - (B) in the event of flooding in the mobile deployment space leading to damage caused to any installation, plant or system of any licensee by the flooding, the developer or owner shall bear all costs incurred by the relevant licensee in replacing such damaged installation, plant or system of the licensee except that where such damaged installation, plant or system is also deployed by the licensee to serve external properties, the developer or owner shall only be obliged to bear a reasonable proportion of such costs attributable to the provision of public cellular mobile telecommunication services to the development;

- (C) in the event of flooding in the mobile deployment space leading to an outage in the provision of public cellular mobile telecommunication services supplied to the development and/or damage caused to any licensee's installation, plant or system, the developer or owner shall:
- (I) promptly inform the tenants of the development that public cellular mobile telecommunication services may be affected as a result of such event; and
 - (II) relocate the mobile deployment space to another location in the first or higher storey of the development and bear all costs in connection therewith except that where the installation, plant or system is also deployed by the licensee at the mobile deployment space to serve external properties, the developer or owner shall only be obliged to bear a reasonable proportion of such costs attributable to the provision of public cellular mobile telecommunication services to the development.

- 8.8.5 Where the relevant development comprises 1 or more buildings, any of which has 30 or more storeys, the developer or owner shall provide the mobile deployment space in 2 or more separate spaces, provided that the total space provided meets the relevant mobile deployment space and each separate space is at least 8m² with a minimum width of at least 2m. In determining the location of such spaces, the developer or owner shall locate them so as to facilitate the provision of public cellular mobile telecommunication services to the whole development.
- 8.8.6 Subject to paragraph 8.8.5, the developer or owner may provide the mobile deployment space in one or more separate spaces, provided that the total space meets the relevant mobile deployment space and each separate space is at least 8m² with a minimum width of at least 2m.
- 8.8.7 The developer or owner shall, at its own cost, comply with any legislation or regulatory requirements in connection with the provision of the mobile deployment space (e.g. obtaining the relevant approvals for conversion of car park lots to mobile deployment space, or installation of fencing or trellis).
- 8.8.8 Where the licensee wishes to install any facilities (e.g. cable trays and power points) required to serve its installation, plant or system at the mobile deployment space, the developer or owner shall provide reasonable assistance to facilitate such installation by the licensee.

8.9 Provision of access to and use of the relevant space and facilities

- 8.9.1 The developer or owner of a development shall, upon reasonable notice being given by a licensee, grant the licensee access to and use of the space and facilities provided pursuant to this Code or any previous codes, for the licensee to inspect, install, maintain, repair and upgrade its installation, plant or system. For the avoidance of doubt, the developer or owner shall ensure

that its own internal processes do not cause any undue delay to the grant of such access under this paragraph 8.9.1.

- 8.9.2 Without prejudice to the generality of paragraph 8.9.1, the developer or owner shall, where it installs a false ceiling obstructing or covering any access to the relevant space and facilities (e.g. cable trays), provide appropriate access panels or openings.
- 8.9.3 The obligation of the developer or owner to provide access shall include removing and/or opening any temporary or permanent structures which are obstructing the licensee's access to the relevant space and facilities, at no cost to the licensee.
- 8.9.4 Where the developer or owner requires the licensee to submit any proposal for cabling works based on the relevant building plans, floor plans or blueprints, the developer or owner shall provide the licensee with at least one (1) set of the relevant building plans, floor plans or blueprints, at no cost to the licensee.
- 8.9.5 Where the relevant space and facilities are located at a height of more than 4m above floor level, the developer or owner shall provide the necessary means for the licensee to access such space and facilities in accordance with prevailing legislation or regulatory requirements on workplace safety and health, at no cost to the licensee. For the avoidance of doubt, this provision does not exempt any party from its relevant obligations under the prevailing legislation or regulatory requirements on workplace safety and health.
- 8.9.6 The developer or owner shall not impose any charge or rent on the licensee (e.g. administrative charges, security escort charges, reinstatement costs) or impose any additional requirements on the licensee (e.g. requiring any insurance policy or additional insurance coverage to be taken) in connection with the grant of access to and use of the space and facilities under paragraph 8.9.1. Without prejudice to the foregoing, the developer or owner may require that a licensee place a deposit in connection with any upgrading, installation or removal works to be carried out by the licensee at the relevant space and facilities, provided that such deposit meets the following requirements:
- (a) the deposit must be refundable (subject to any deductions based on reasonable criteria that have been made known to the licensee in advance);
 - (b) the deposit must be refunded to the licensee promptly after completion of the upgrading, installation or removal works; and
 - (c) the deposit must be of a reasonable amount, taking into consideration the scope of the installation works.

8.10 Relevant space and facilities to be ready 6 months prior to the date of issuance of temporary occupation permit by the relevant authority

- 8.10.1 Where the developer or owner wishes to have telecommunication services (including public cellular mobile telecommunication services) provided to the development commencing from the date of issuance of the temporary occupation permit by the relevant authority (“TOP Date”), the developer or owner shall ensure that the relevant space and facilities (e.g. mobile deployment space, main distribution frame room, telecommunication risers and lead-in pipes) are ready for use by the licensees at least 6 months before the TOP Date.

CHAPTER 9. DEVELOPMENT CONSISTING OF 1 OR MORE NON-RESIDENTIAL BUILDINGS OF A TOTAL USABLE FLOOR AREA OF UP TO AND INCLUDING 2,000m²

9.1 Application of this chapter

9.1.1 This chapter specifies the space and facilities to be provided for a development, consisting of 1 or more non-residential buildings, of a total usable floor area of up to and including 2,000m². IDA reserves the right to require any developer or owner to provide additional space and facilities, to meet the demand for telecommunication services where necessary.

9.2 Provision of the main distribution frame room

9.2.1 A main distribution frame room shall be provided in every relevant development. Where:

- (a) there is no basement level or a single basement level, the main distribution frame room shall be located on the first or second storey of the relevant development; and
- (b) there are multiple basement levels, the main distribution frame room shall be located:
 - (i) on the first or second storey; or
 - (ii) on the uppermost basement level provided that:
 - (A) in the event of flooding in the main distribution frame room leading to an outage in the provision of telecommunication services supplied to the development, the developer or owner shall bear all costs incurred by the relevant licensee in restoring the telecommunication services in the development except that where the relevant licensee is restoring such services to the development and external properties, the developer or owner shall only be obliged to bear a reasonable proportion of such costs attributable to the provision of telecommunication services to the development;
 - (B) in the event of flooding in the main distribution frame leading to damage caused to any installation, plant or system of any licensee by the flooding, the developer or owner shall bear all costs incurred by the relevant licensee in replacing such damaged installation, plant or system of the licensee except that where such damaged installation, plant or system is also deployed by the licensee to serve external properties, the developer or owner shall only be obliged to bear a reasonable proportion of such costs attributable to the provision of telecommunication services to the development; and

- (C) in the event of flooding in the main distribution frame room leading to an outage in the provision of telecommunication services supplied to the development and/or damage caused to any licensee's installation, plant or system, the developer or owner shall:
 - (I) promptly notify the tenants of the development that telecommunication services may be affected as a result of such event; and
 - (II) relocate the main distribution frame room to another location in the first or second storey of the development and bear all costs in connection therewith except that where the installation, plant or system is also deployed by the licensee at the main distribution frame room to serve external properties, the developer or owner shall only be obliged to bear a reasonable proportion of such costs attributable to the provision of telecommunication services to the development.
- 9.2.2 The minimum dimensions of the main distribution frame room shall be 3m (length) by 2m (breadth) by 3.5m (height).
- 9.2.3 The developer or owner shall, in accordance with the requirements set out in chapter 11, provide for ventilation of the main distribution frame room by way of:
- (a) air-conditioning from the central system (where central air-conditioning system is provided in the relevant development); or
 - (b) louvres and/or exhaust fans.
- 9.2.4 3 sets of electrical distribution panels operating on 230V, single phase, 50Hz power supply connecting to three (3) 2-gang 13A switch socket outlets and three (3) 20A isolators shall be provided in the main distribution frame room.
- 9.2.5 Every electrical distribution panel shall contain –
- (a) a 30mA residual current circuit breaker of appropriate electrical current rating and miniature circuit breakers for final circuit connections and to facilitate the installation of electrical meters;
 - (b) 2 spare 20A miniature circuit breakers; and
 - (c) a single-line diagram in each panel.
- 9.2.6 Where a standby power generator is provided in the relevant development, the power supply to the main distribution frame room shall be connected to such standby power generator.
- 9.2.7 Natural and/or electrical lighting shall be provided in the main distribution frame room.

- 9.2.8 Electrical switch socket outlets shall be provided in the main distribution frame room which are to be distributed evenly between the 3 sets of electrical distribution panels.
- 9.2.9 A clean earth of 1Ω or less (without the use of salt) shall be provided for the exclusive use of telecommunication installation or plant in the main distribution frame room. The clean earth shall be connected directly to:
- (a) an independent earth electrode system; and
 - (b) the development's electrical safety earth system.
- 9.2.10 The clean earth that is provided pursuant to paragraph 9.2.9 shall be in the form of a copper earth bar of at least 300mm in length, 8mm in width and 5mm in thickness, with screw holes that are 6mm in diameter.
- 9.2.11 In addition to the requirements set out in paragraphs 9.2.1 to 9.2.10, the main distribution frame room shall be provided in accordance with the requirements set out in chapter 12.

9.3 Provision of lead-in pipes, underground pipes and manholes

- 9.3.1 A minimum of 6 continuous lead-in pipes and underground pipes shall be provided for the relevant development as follows –
- (a) the lead-in pipes shall extend from the boundary of the development to the abutting road, to a point 1m beyond the roadside drain located immediately outside the development; and
 - (b) the underground pipes shall connect from the lead-in pipes at the boundary of the development and run to the main distribution frame room.
- 9.3.2 For the purpose of paragraph 9.3.1 all lead-in pipes and underground pipes shall be made of unplasticised polyvinyl chloride (uPVC) material with a nominal diameter of 110mm and be compliant with the Singapore Standard SS:272.
- 9.3.3 In addition to the requirements set out in paragraphs 9.3.1 to 9.3.2, all lead-in pipes and underground pipes shall be provided in accordance with the requirements set out in chapter 11.
- 9.3.4 Manholes shall be provided in each relevant development as follows –
- (a) a manhole shall be constructed at every location where there is effectively an approximately 90° or sharper bend in the direction of the underground pipes; and
 - (b) a minimum of 1 manhole must be provided for every 150m segment of underground pipes laid.
- 9.3.5 The manholes to be provided under paragraph 9.3.4 shall be of type MX1.

- 9.3.6 In addition to the requirements set out in paragraphs 9.3.4 to 9.3.5, all manholes shall be provided in accordance with the requirements set out in chapter 11.

9.4 Provision of telecommunication risers

- 9.4.1 Telecommunication riser shall be provided in every non-residential multi-storey building in the relevant development.
- 9.4.2 The serving radius of each telecommunication riser shall not exceed 40m. Each telecommunication riser shall be labelled as "Telecom Riser" and numbered for easy reference and identification.
- 9.4.3 All telecommunication riser shafts shall be constructed in a direct vertical line throughout the building.
- 9.4.4 The internal dimensions of a telecommunication riser shall be 600mm (width) x 450mm (depth) at the minimum.
- 9.4.5 Every telecommunication riser shall have a door which can be fully opened outwards throughout its entire width for easy access at each floor level. The height of the door shall be at least 2,100mm and the width of the door shall be at least 500mm.
- 9.4.6 All doors of the telecommunication risers shall be locked.
- 9.4.7 A minimum of 2 cable trays, with a minimum width of 300mm each, shall be provided in each telecommunication riser from the bottommost level to the topmost level of every non-residential building, of which -
- (a) a minimum of 1 cable tray shall be used for non-coaxial cables; and
 - (b) a minimum of 1 cable tray shall be used for coaxial cables.
- 9.4.8 The cable trays for non-coaxial cables and coaxial cables shall be installed opposite each other on the side walls of the telecommunication riser.
- 9.4.9 The telecommunication riser openings on every storey in each building shall be sealed in accordance with the Code of Practice for Fire Precautions in Buildings issued by Singapore Civil Defence Force.
- 9.4.10 In addition to the requirements set out in paragraphs 9.4.1 to 9.4.9, all telecommunication risers shall be provided in accordance with the requirements set out in chapter 13.

9.5 Provision of horizontal cable trays from the main distribution frame room to each telecommunication riser

- 9.5.1 A minimum of 2 cable trays, with a minimum width of 300mm each, shall be provided from the main distribution frame room to each telecommunication riser, of which -

- (a) a minimum of 1 cable tray shall be used for non-coaxial cables; and
- (b) a minimum of 1 cable tray shall be used for coaxial cables.
- 9.5.2 Slots of a minimum height of 300mm shall be provided in the wall of each telecommunication riser for cable trays to pass through.

9.6 Provision of a cable distribution system from the telecommunication riser to each non-residential unit

- 9.6.1 A cable distribution system shall be provided to facilitate the laying of non-coaxial cables and coaxial cables from the telecommunication riser to each non-residential unit. The developer or owner may select an appropriate cable distribution system as described in the Guidelines For Info-communications Facilities in Buildings.

9.7 Provision of mobile deployment space

- 9.7.1 If the relevant development consists of 1 or more non-residential buildings with a total mobile coverage area of more than 2,000m², the developer or owner shall, where required and notified by any mobile telecommunication licensee, provide within a reasonable time, mobile deployment space in accordance with the dimensions as specified in Table 9.7.1 based on the mobile coverage area in the development. If the relevant development consists of a total mobile coverage area of more than 200,000m², the developer or owner shall consult IDA on the mobile deployment space to be provided and comply with such requirements as may be imposed by IDA.

Table 9.7.1 Mobile deployment space to be provided in each relevant development

Total mobile coverage area ('000 m ²)	Mobile deployment space (m ²)		Minimum height of mobile deployment space (m)
	Where the mobile deployment space is provided as a single space	Where the mobile deployment space is provided as two or more separate spaces	
> 2 to ≤ 6	18	24*	3
> 6 to ≤ 20	36*		
> 20 to ≤ 100	54*		
> 100 to ≤ 200	72*		
> 200	To consult IDA		

* Size of each disaggregated MDS shall be at least 8m²

- 9.7.2 The developer or owner of an underground MRT station or facility building (associated with a road tunnel) shall be deemed to have satisfied the requirements set out in paragraph 9.7.1 in relation to such underground MRT station or facility building where the developer or owner has already provided mobile deployment space in accordance with paragraphs 10.2 and 10.3 of chapter 10.

9.7.3 The developer or owner may locate the mobile deployment space to be provided under paragraph 9.7.1 at any unused space in the development (e.g. carpark and roof top), subject to the additional requirements provided in paragraphs 9.7.4 to 9.7.5 and chapter 12. For the avoidance of doubt, the mobile deployment space shall not be located in the main distribution frame room, unless there is sufficient space available after having fulfilled the space requirements of the main distribution frame room and there is a clear demarcation of the space designated as mobile deployment space.

9.7.4 Where:

- (a) there is no basement level or a single basement level, the mobile deployment space shall be located on the first or higher storey of the relevant development; and
- (b) there are multiple basement levels, the mobile deployment space shall be located:
 - (i) on the first or higher storey; or
 - (ii) on the uppermost basement level provided that:
 - (A) in the event of flooding in the mobile deployment space leading to an outage in the provision of public cellular mobile telecommunication services supplied to the development, the developer or owner shall bear all costs incurred by the relevant licensee in restoring the public cellular mobile telecommunication services in the development except that where the relevant licensee is restoring such services to the development and external properties, the developer or owner shall only be obliged to bear a reasonable proportion of such costs attributable to the provision of public cellular mobile telecommunication services to the development;
 - (B) in the event of flooding in the mobile deployment space leading to damage caused to any installation, plant or system of any licensee by the flooding, the developer or owner shall bear all costs incurred by the relevant licensee in replacing such damaged installation, plant or system of the licensee except that where such damaged installation, plant or system is also deployed by the licensee to serve external properties, the developer or owner shall only be obliged to bear a reasonable proportion of such costs attributable to the provision of public cellular mobile telecommunication services to the development;
 - (C) in the event of flooding in the mobile deployment space leading to an outage in the provision of public cellular mobile telecommunication services supplied to the development and/or damage caused to any licensee's installation, plant or system, the developer or owner shall:

- (I) promptly notify the tenants of the development that public cellular mobile telecommunication services may be affected as a result of such event; and
- (II) relocate the mobile deployment space to another location in the first or higher storey of the development and bear all costs in connection therewith except that where the installation, plant or system is also deployed by the licensee at the mobile deployment space to serve external properties, the developer or owner shall only be obliged to bear a reasonable proportion of such costs attributable to the provision of public cellular mobile telecommunication services to the development.

9.7.5 Where the relevant development comprises 1 or more buildings, any of which has 30 or more storeys, the developer or owner shall provide the mobile deployment space in 2 or more separate spaces, provided that the total space provided meets the relevant mobile deployment space and each separate space is at least 8m² with a minimum width of at least 2m. In determining the location of such spaces, the developer or owner shall locate them so as to facilitate the provision of public cellular mobile telecommunication services to the whole development.

9.7.6 The developer or owner may provide the mobile deployment space in one or more separate spaces provided that the total space provided meets the relevant mobile deployment space and each separate space is at least 8m² with a minimum width of at least 2m.

9.7.7 The developer or owner shall, at its own cost, comply with any legislation or regulatory requirements in connection with the provision of the mobile deployment space (e.g. obtaining the relevant approvals for conversion of car park lots to mobile deployment space, or installation of fencing or trellis).

9.7.8 Where the licensee wishes to install any facilities (e.g. cable trays and power points) required to serve its installation, plant or system at the mobile deployment space, the developer or owner shall provide reasonable assistance to facilitate such installation by the licensee.

9.8 Provision of access to and use of the relevant space and facilities

9.8.1 The developer or owner of a development shall, upon reasonable notice being given by a licensee, grant the licensee access to and use of the space and facilities provided pursuant to this Code or any previous codes, for the licensee to inspect, install, maintain, repair and upgrade its installation, plant or system. For the avoidance of doubt, the developer or owner shall ensure that its own internal processes do not cause any undue delay to the grant of such access under this paragraph 9.8.1.

9.8.2 Without prejudice to the generality of paragraph 9.8.1, the developer or owner shall, where it installs a false ceiling obstructing or covering any access to the relevant space and facilities (e.g. cable trays), provide appropriate access panels or openings.

- 9.8.3 The obligation of the developer or owner to provide access shall include removing and/or opening any temporary or permanent structures which are obstructing the licensee's access to the relevant space and facilities, at no cost to the licensee.
- 9.8.4 Where the developer or owner requires the licensee to submit any proposal for cabling works based on the relevant building plans, floor plans or blueprints, the developer or owner shall provide the licensee with at least one (1) set of the relevant building plans, floor plans or blueprints, at no cost to the licensee.
- 9.8.5 Where the relevant space and facilities are located at a height of more than 4m above floor level, the developer or owner shall provide the necessary means for the licensee to access such space and facilities in accordance with prevailing legislation or regulatory requirements on workplace safety and health, at no cost to the licensee. For the avoidance of doubt, this provision does not exempt any party from its relevant obligations under the prevailing legislation or regulatory requirements on workplace safety and health.
- 9.8.6 The developer or owner shall not impose any charge or rent on the licensee (e.g. administrative charges, security escort charges, reinstatement costs) or impose any additional requirements on the licensee (e.g. requiring any insurance policy or additional insurance coverage to be taken) in connection with the grant of access to and use of the space and facilities under paragraph 9.8.1. Without prejudice to the foregoing, the developer or owner may require that a licensee place a deposit in connection with any upgrading, installation or removal works to be carried out by the licensee at the relevant space and facilities, provided that such deposit meets the following requirements:
- (a) the deposit must be refundable (subject to any deductions based on reasonable criteria that have been made known to the licensee in advance);
 - (b) the deposit must be refunded to the licensee promptly after completion of the upgrading, installation or removal works; and
 - (c) the deposit must be of a reasonable amount, taking into consideration the scope of the installation works.

9.9 Relevant space and facilities to be ready 6 months prior to the date of issuance of temporary occupation permit by the relevant authority

- 9.9.1 Where the developer or owner wishes to have telecommunication services (including public cellular mobile telecommunication services) provided to the development commencing from the date of issuance of the temporary occupation permit by the relevant authority ("TOP Date"), the developer or owner shall ensure that the relevant space and facilities (e.g. mobile deployment space, main distribution frame room, telecommunication risers and lead-in pipes) are ready for use by the licensees at least 6 months before the TOP Date.

CHAPTER 10 DEVELOPMENT CONSISTING OF 1 OR MORE ROAD OR MRT TUNNELS

10.1 Application of this chapter

- 10.1.1 This chapter specifies the space and facilities to be provided for a development which consists of 1 or more road or MRT tunnels. IDA reserves the right to require any developer or owner to provide additional space and facilities, to meet the demand for telecommunication services where necessary.
- 10.1.2 Where a development consists of 1 or more non-residential buildings in addition to 1 or more road or MRT tunnels, the developer or owner shall also refer to chapter 8 or 9 (as the case may be) for the relevant space and facilities requirements for the non-residential building within the development.

10.2 Provision of mobile deployment space for road tunnel coverage

- 10.2.1 Subject to paragraph 10.2.2, the developer or owner shall provide mobile deployment space in each relevant development which consists of 1 or more road tunnels as follows:
- (a) For every facility building (or its equivalent) that is associated with road tunnels, the developer or owner shall provide a mobile deployment space of 40m² in each such facility building (or its equivalent) or within the vicinity of such road tunnels; or
 - (b) Where any road tunnel is not associated with any facility building, the developer or owner shall provide a mobile deployment space of 40m² within the vicinity of such road tunnels.
- 10.2.2 Where the relevant development consists of 1 or more road tunnels each of which is 1 km or shorter, the developer or owner shall consult IDA on the mobile deployment space to be provided for each such tunnel and comply with such requirements as may be imposed by IDA.

10.3 Provision of mobile deployment space for MRT tunnel coverage

- 10.3.1 For every MRT line, the developer or owner shall provide a mobile deployment space of 40m² in each underground MRT station associated with that MRT line. For the avoidance of doubt, where the underground MRT station is associated with more than 1 MRT line, the developer or owner shall provide a separate mobile deployment space of 40m² for each MRT line associated with it.

10.4 Provision of access to and use of the relevant space and facilities

- 10.4.1 The developer or owner of a development shall, upon reasonable notice being given by a licensee, grant the licensee access to and use of the space and facilities provided pursuant to this Code or any previous codes, for the licensee to inspect, install, maintain, repair and upgrade its installation, plant

or system. For the avoidance of doubt, the developer or owner shall ensure that its own internal processes do not cause any undue delay to the grant of such access under this paragraph 10.4.1.

- 10.4.2 Without prejudice to the generality of paragraph 10.4.1, the developer or owner shall, where it installs a false ceiling obstructing or covering any access to the relevant space and facilities (e.g. cable trays), provide appropriate access panels or openings.
- 10.4.3 The obligation of the developer or owner to provide access shall include removing and/or opening any temporary or permanent structures which are obstructing the licensee's access to the relevant space and facilities, at no cost to the licensee.
- 10.4.4 Where the developer or owner requires the licensee to submit any proposal for cabling works based on the relevant building plans, floor plans or blueprints, the developer or owner shall provide the licensee with at least one (1) set of the relevant building plans, floor plans or blueprints, at no cost to the licensee.
- 10.4.5 Where the relevant space and facilities are located at a height of more than 4m above floor level, the developer or owner shall provide the necessary means for the licensee to access such space and facilities in accordance with prevailing legislation or regulatory requirements on workplace safety and health, at no cost to the licensee.
- 10.4.6 The developer or owner shall not impose any charge or rent on the licensee (e.g. administrative charges, security escort charges, reinstatement costs) or impose any additional requirements on the licensee (e.g. requiring any insurance policy or additional insurance coverage to be taken) in connection with the grant of access to and use of the space and facilities under paragraph 10.4.1. Without prejudice to the foregoing, the developer or owner may require that a licensee place a deposit in connection with any upgrading, installation or removal works to be carried out by the licensee at the relevant space and facilities, provided that such deposit meets the following requirements:
- (a) the deposit must be refundable (subject to any deductions based on reasonable criteria that have been made known to the licensee in advance);
 - (b) the deposit must be refunded to the licensee promptly after completion of the upgrading, installation or removal works; and
 - (c) the deposit must be of a reasonable amount, taking into consideration the scope of the installation works.

CHAPTER 11. LEAD-IN PIPES, UNDERGROUND PIPES AND MANHOLES

11.1 Overview

11.1.1 This chapter sets out the additional requirements for the provision of –

- (a) lead-in pipes;
- (b) underground pipes; and
- (c) manholes.

11.1.2 The quantities of lead-in pipes, underground pipes and manholes specified in this Code are the required to be provided. IDA reserves the right to require any developer or owner to provide additional lead-in pipes, underground pipes and manholes to meet the demand for telecommunication services where necessary.

11.2 Qualified builders

Every developer or owner who is required to provide lead-in pipes or an underground pipeline system or both shall ensure that they are constructed by builders who are registered with the Building and Construction Authority under the CR07 (Construction Related Workhead) category specialising in “Cable/Pipe Laying and Road Reinstatement”. The list of registered contractors may be obtained from the Building and Construction Authority website (<http://www.bca.gov.sg>).

11.3 General requirements for all pipes

11.3.1 Every developer or owner who is required to provide lead-in pipes or underground pipes or both shall for such purpose –

- (a) use only pipes and associated couplings that are made from unplasticised polyvinyl chloride (uPVC) material which are compliant with the Singapore Standard SS:141 Class C, Singapore Standard SS:272 or its equivalent;
- (b) use only pipes and associated couplings that are no darker than the grey colour;
- (c) provide all pipes in lengths of 6.0m as specified in the Singapore Standard SS:141 Class C, Singapore Standard SS:272 or its equivalent;
- (d) provide all pipes complete with 1 coupling per pipe;
- (e) ensure that all pipes are clearly, indelibly and continuously marked at intervals of not more than 1.0m along the length of the pipe using a distinctive colour with the following description –

- (i) Manufacturer's identification/110mm uPVC pipe/Day/Month/Year/SS141; or
 - (ii) Manufacturer's identification/110mm uPVC pipe/Day/Month/Year/SS272
(as the case may be).
- (f) ensure that all associated couplings are manufactured by injection moulding method. Details for coupling are shown in Figure 11.1. The coupling shall comply to all tests as specified in the Singapore Standard SS:272 or its equivalent;
- (g) ensure that all associated couplings are of the dimensions and tolerances specified in Table 11.3.1(g) below;

Table 11.3.1(g) Dimension and tolerance of couplings

Coupling Length	180.0mm \pm 2.0mm
Internal Diameter	At the edges: 111.5mm + 0.2mm – 0.0mm At the centre: 111.0mm + 0.0mm – 0.2mm
Wall Thickness	Average Value: 3.2mm + 0.4mm – 0.0mm Individual Value: 3.0mm (min)
Wall thickness for a length of 15mm from both ends of the coupling shall increase to:	Average Value: 4.7mm + 0.3mm Individual Value: 4.2mm (min)

- (h) lay all pipes throughout in a straight run as far as practicable;
- (i) join all pipes together using a coating of solvent cement to both couplings and pipes;
- (j) where a bend is required to any pipe, use a factory-made bend of nominal diameter of 110mm and 50mm as illustrated in Figure 11.2(a) & (b) for 90° upturns (i.e. changing from the horizontal to vertical plane) and, unless otherwise advised by the Telecommunication Facility Co-ordination Committee, ensure that the pipe is clipped and flushed against the wall and rises up to a height of 1m above ground as illustrated in Figure 11.2(c) & (d);
- (k) where a straight pipe reducer is required to reduce the nominal diameter of the pipe from 110mm to 50mm or from 50mm to 25mm, use a pipe reducer in accordance with the specifications shown in Figure 11.3(a) & (b);
- (l) construct all pipes located below carriageways at a minimum depth of 1m;
- (m) construct all pipes located below side-tables or footpaths at a minimum depth of 1.2m;
- (n) ensure that all pipes that are buried in the ground under vehicular access are encased in 50mm concrete surround of Grade 20;

- (o) provide a nylon/polyethylene rope of 4-core or multi-strand type with overall diameter of 6mm in every pipe to facilitate cable pulling;
- (p) cap the unconnected ends of all pipes with rubber caps to prevent entry of earth, debris or cement except those ends terminating in manholes and those ends required to be sealed in another manner in accordance with this Code;
- (q) separate all pipes from power cables by no less than –
 - (i) 50mm of concrete surround of Grade 20; or
 - (ii) 300mm in well tamped earth;
- (r) where the underground pipes enter a building in a horizontal position, install a cable duct sealing module system such as MCT, SVT, ROX or BST types as described in Appendix 2 of the Guidelines For Information Facilities in Buildings to prevent the ingress of water and construct a drain below the module system to allow for the drainage of water;
- (s) where the main distribution frame room or telecommunication equipment room is located in the basement of the building, ensure that the underground pipes do not lead directly into the room but connect to cable trays installed outside the main distribution frame room or telecommunication equipment room for entry via such cable trays into the room;
- (t) ensure that all pipes terminating inside the telecommunication risers are flush against the wall and rise up to a minimum height of 1m;
- (u) ensure that all lead-in pipes and the underground pipeline system are constructed in accordance with the practice as illustrated in Figure 11.34; and
- (v) ensure that all pipes are free of obstructing materials and substances to facilitate the deployment of cables by licensees.

11.4 Specific requirements for lead-in pipes

11.4.1 Every developer or owner who is required to provide lead-in pipes shall –

- (a) construct all lead-in pipes at a depth of no less than 1m from the base of (i.e. to under-cross) the existing or proposed roadside drain in accordance with the requirements of the relevant authorities except that where it is not possible for the lead-in pipes to under-cross the roadside drain, the owner shall consult IDA on the construction of such lead-in pipes and comply with such requirements as may be imposed by IDA;
- (b) orientate all lead-in pipes to face public roads and ensure that they are not constructed into State Land (i.e. backlane) or oriented to face the direction of trees, lamp posts, traffic lights, road signs, over-ground boxes (OG boxes) or other permanent obstacles;

- (c) ensure that the number of lead-pipes provided is equivalent to and no less than the number of pipes in the underground pipeline system entering the main distribution frame room;
- (d) where a common services tunnel (CST) or an equivalent type of tunnel system is constructed for the laying of telecommunication cables to building developments (for example, the CST constructed in the Marina South new downtown area) –
 - (i) construct and connect the lead-in pipes to the pipe-sleeves of the designated CST junction box adjacent to the building or building development and obtain all necessary approvals from the relevant authorities for such connection works; and
 - (ii) ensure that the number of lead-in pipes provided is equivalent to and corresponds with the number of pipe-sleeves of the designated CST junction box, notwithstanding the quantities of lead-in pipes specified in the relevant chapters of this Code; and
- (e) indicate the position of the lead-in pipes by a marker on the final ground level and indicate by such marker that these pipes are for telecommunication use.

11.4.2 The developer or owner is advised to consult the Telecommunication Facility Co-ordination Committee for guidance on the most suitable location and orientation for its lead-in pipes.

11.4.3 Figure 11.4 shows a typical layout of lead-in pipes in a gate pillar of a landed dwelling house.

11.5 Specific requirements for the provision of underground pipes

11.5.1 Every developer or owner who is required to provide underground pipes shall –

- (a) where multi-way pipes are used, ensure that spacers are installed;
- (b) where the laying of the underground pipes is obstructed by other services or deep culverts which require the under-crossing or over-crossing of such obstacles, lay the pipes in a gradual gradient of not less than 1:6 for pipes of nominal diameter of 110mm and not less than 1:3 for pipes of nominal diameter of 50mm; and
- (c) ensure that the number of underground pipes connecting from the lead-in pipes to the main distribution frame room or telecommunication equipment room is equivalent to and corresponds with the number of lead-in pipes.

11.5.2 Developers or owners are advised to refer to the testing procedures specified in Appendix 3 of the Guidelines for Info-communication Facilities in Buildings for the testing of the underground pipes.

11.6 Manholes

- 11.6.1 Where manholes of type JX2, MX1, MX2, MX3, MX4 or MX5 are constructed, the developer or owner shall comply with the specifications set out in Figures 11.5 to 11.33 in relation to such manholes.
- 11.6.2 Where it is necessary for larger manholes (type MX6 and above) or non-standard manholes or irregular manholes to be constructed, the developer or owner shall obtain the specifications for such manholes from the Telecommunication Facility Co-ordination Committee.
- 11.6.3 Before any concrete is laid for the construction of any manhole, the developer or owner shall ensure that –
- (a) the bottom of the excavation is properly levelled and consolidated;
 - (b) the bottom of the excavation is kept dry by providing a sump-hole to accommodate water pump, and where necessary provide a layer of 150mm thick hard-core materials;
 - (c) pipes are cast on site and that manhole fittings are placed as the construction proceeds;
 - (d) uPVC pipes with a flared mouth at one end and which comply with the Singapore Standard SS:272 are used for entry into the wall of the manhole;
 - (e) the underground pipes enter each manhole in the manner shown in Figures 11.5 to 11.14, 11.19 to 11.22 & 11.27 to 11.33, and at such depths as to ensure a minimum clearance of 450mm above the floor level and 350mm below the roof unless otherwise specified;
 - (f) the manhole is constructed at a depth which allows for a concrete (1:2:4) shaft wall of varying height to be constructed for the various manhole sizes shown in Figures 11.15 to 11.18 & 11.23 to 11.26;
 - (g) the concrete used for filling the recess of the manhole frame and cover is of Grade 20 and that such filling is flush with the top of the cover, and where heavy duty frame and cover is used, ensure that the concrete is filled up to the ribs without covering the ribs;
 - (h) manhole walls are fair faced and not rendered, and that all projections or cavities in the manhole walls are removed or filled with cement mortar respectively;
 - (i) the manhole walls are not coated with cement or cement sand wash;
 - (j) the floor of the manhole is given a 20mm rendering of cement mortar with fall towards the sump-hole from all directions;
 - (k) 1 uPVC pipe of nominal diameter of 50mm with a 1-way trap is constructed at the neck of the manhole and connected to the nearest drain that is situated at a lower level than the manhole;

- (l) only approved formwork is used in the construction of manholes;
 - (m) where the manhole is constructed under carriageways or vehicular access areas, a heavy duty manhole cover which complies with the Singapore Standard SS 30 Grade A1 is used for such manhole; and
 - (n) where the manhole is constructed under turfed areas or pedestrian footways, a medium duty manhole cover which complies with the Singapore Standard SS 30 Grade B is used for such manhole.
- 11.6.4 The developer or owner may choose to install pre-cast manholes as an alternative to constructing the manholes.
- 11.6.5 The developer or owner may purchase manhole frames, covers and channel brackets directly from suppliers or from licensees. Every developer or owner shall ensure that the manhole covers which he provides do not bear the name of any licensee.

FIGURE 11.1: INJECTION MOULDED UPVC COUPLING FOR 110MM NOMINAL SIZE UPVC PIPE

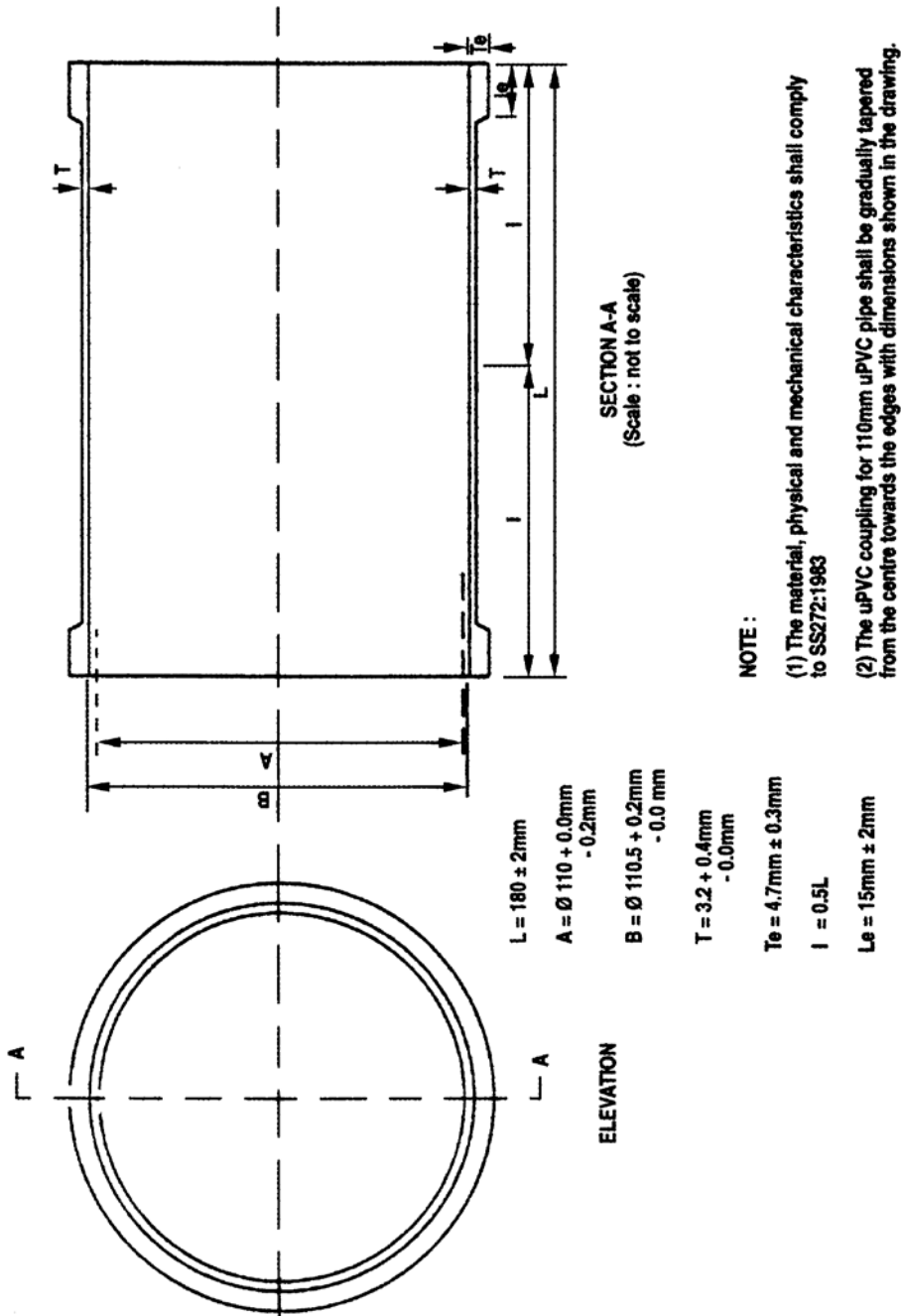

FIGURE 11.2(a): 110MM DIAMETER UPVC BEND PIPE

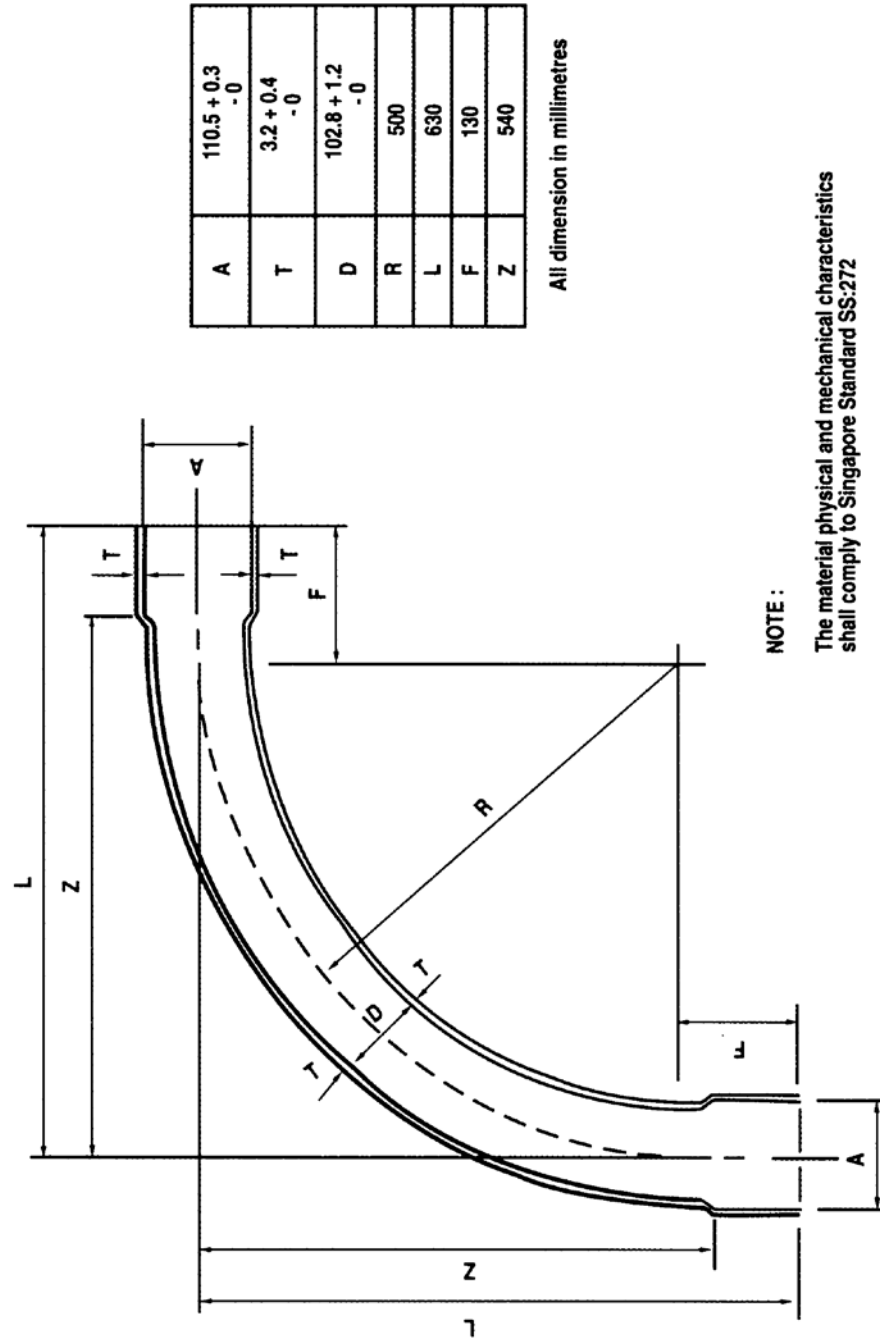

FIGURE 11 .2(b): 50MM DIAMETER UPVC BEND PIPE

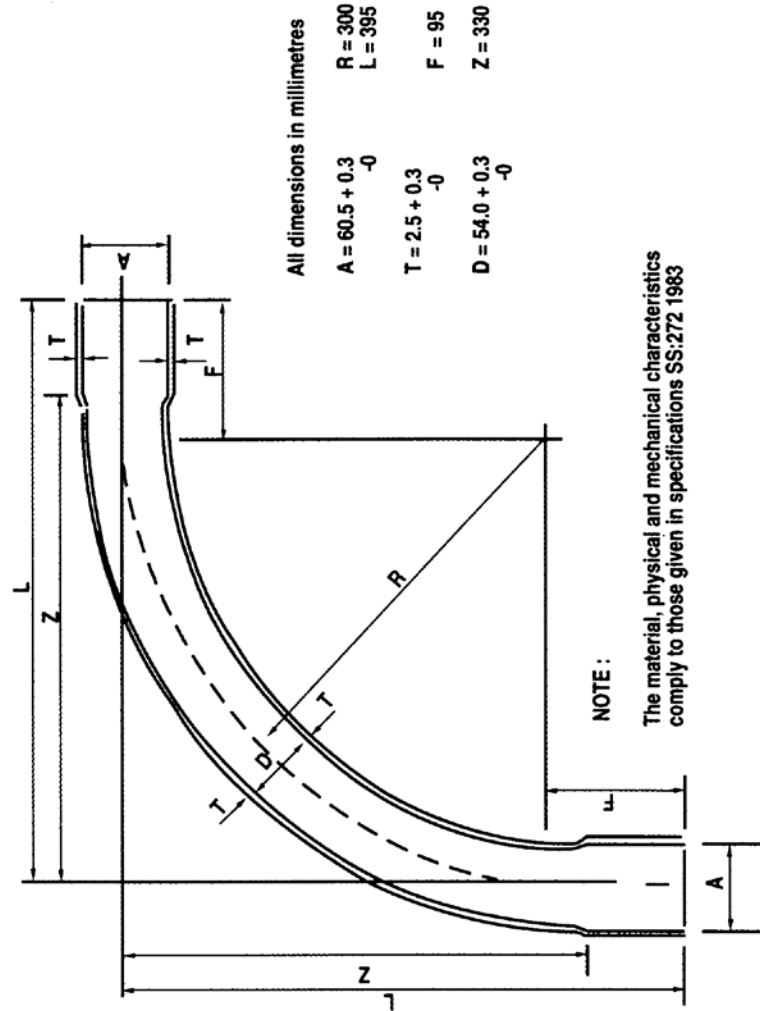

FIGURE 11.2(c): DETAILS OF LEAD-IN PIPES WITH BEND PIPES

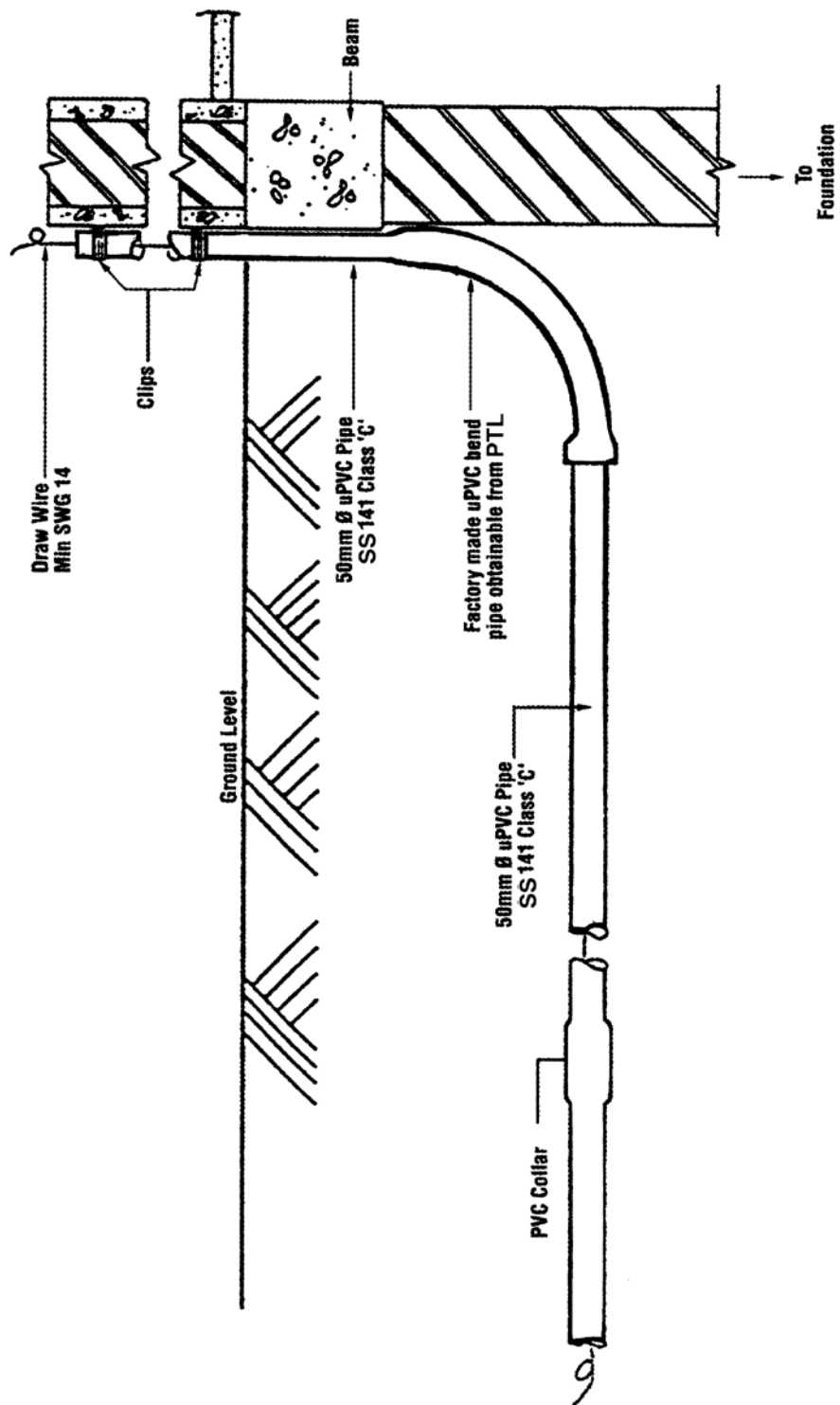

FIGURE 11 .2(d): DETAILS OF LEAD-IN PIPES WITH BEND PIPES

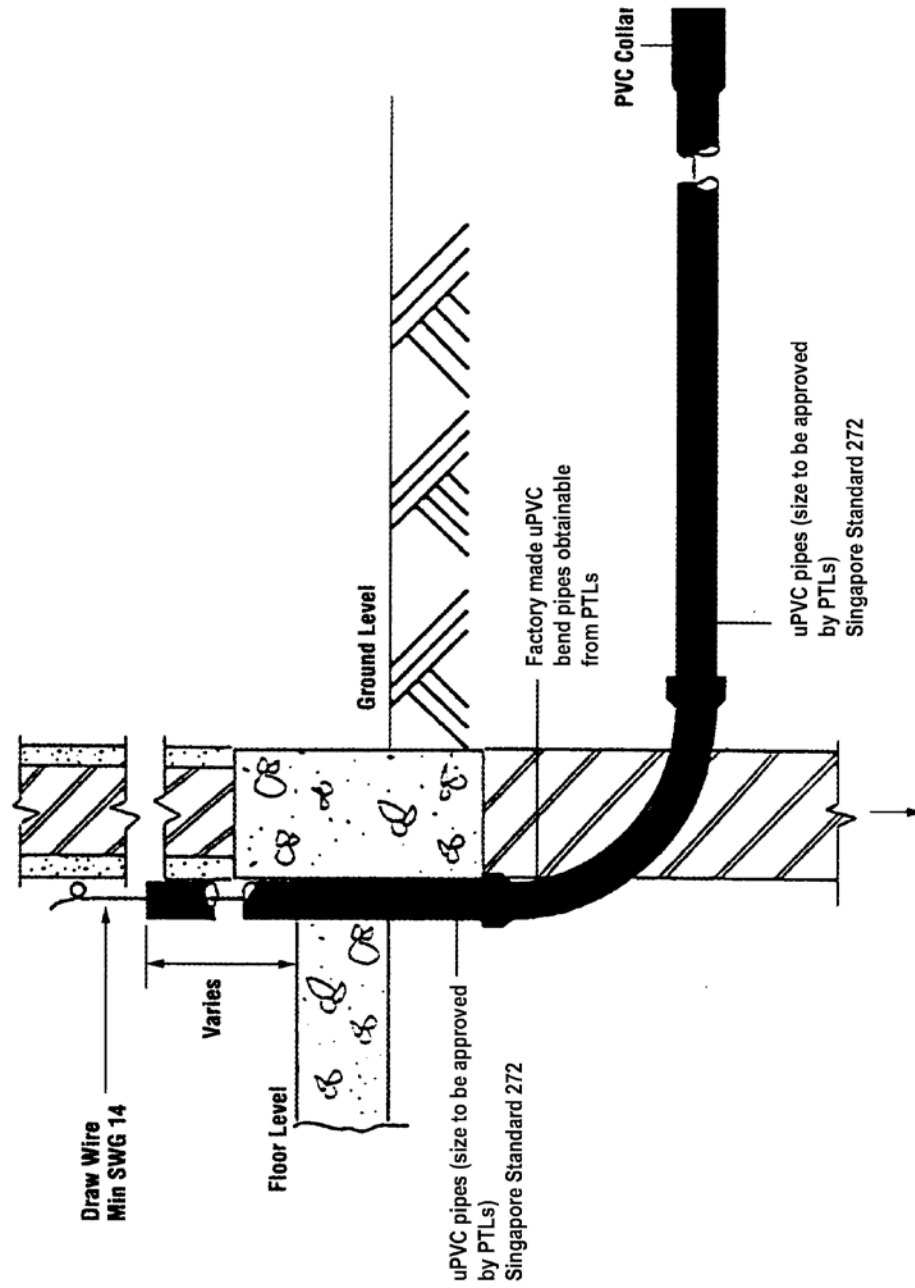
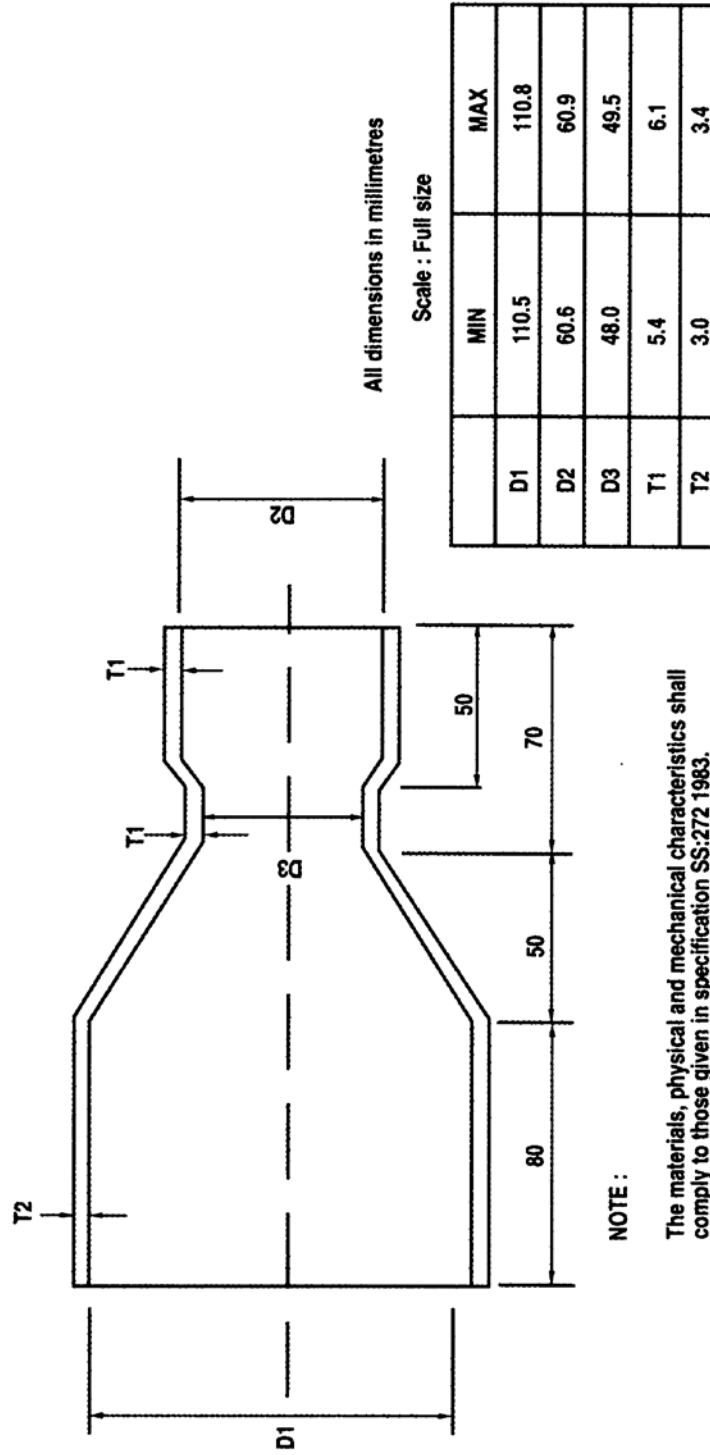
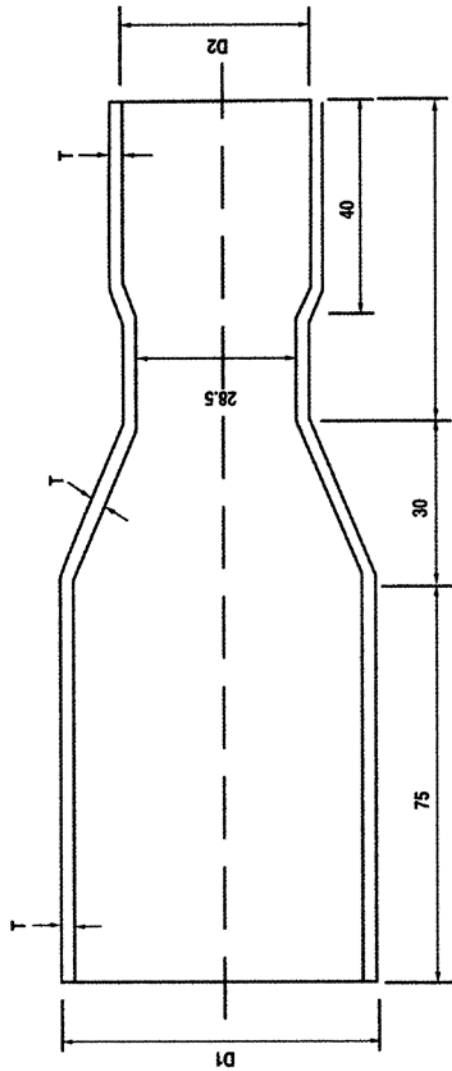

FIGURE 11.3(a): REDUCER FOR 110MM TO 50MM DIAMETER NOMINAL SIZE UPVC PIPE



**FIGURE 11.3(b): REDUCER FOR 50MM TO 25MM NOMINAL SIZE
UPVC PIPE**



NOTE :

The materials, physical and mechanical characteristics shall comply to those given for 110mm Ø nominal size UPVC pipe in accordance to Singapore Standard SS:272 1983.

All dimensions in millimetres

	MIN	MAX
D1	60.2	60.5
D2	33.7	34.0
T	2.7	3.0

FIGURE 11.4: LOCATION OF LEAD-IN PIPES IN GATE PILLAR

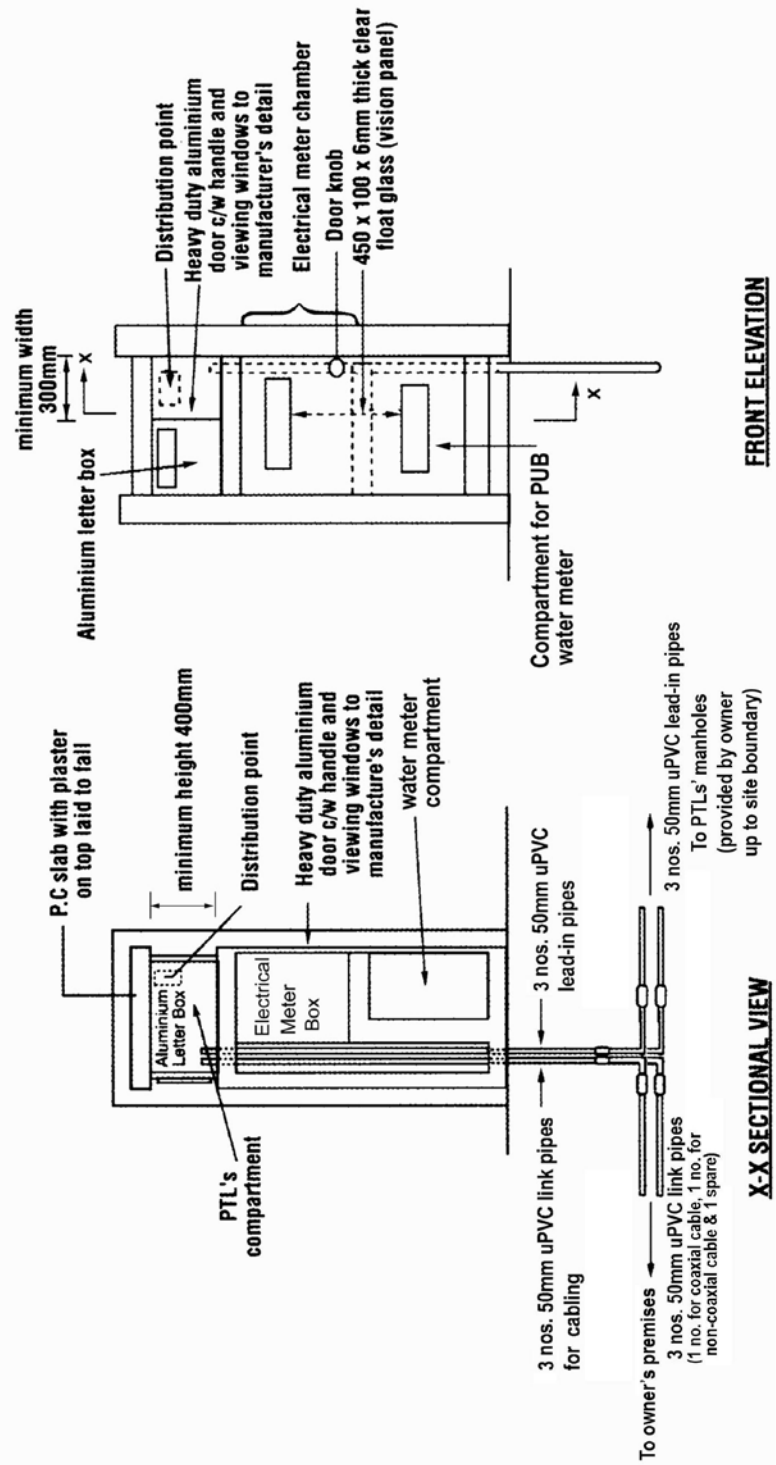

FIGURE 11.5: MANHOLE DRAWINGS - TYPE JX2

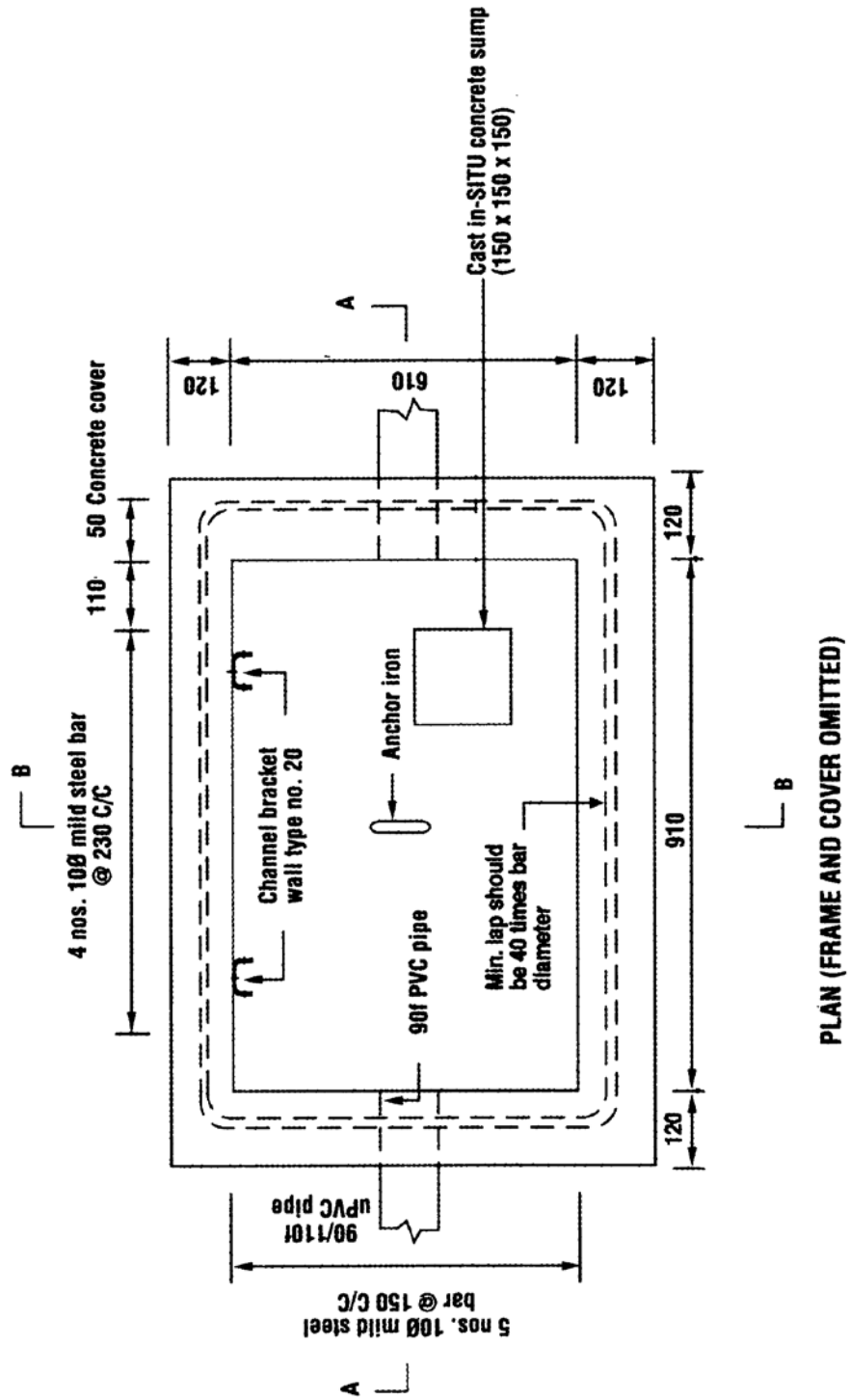

FIGURE 11.7: MANHOLE DRAWINGS - TYPE MX1

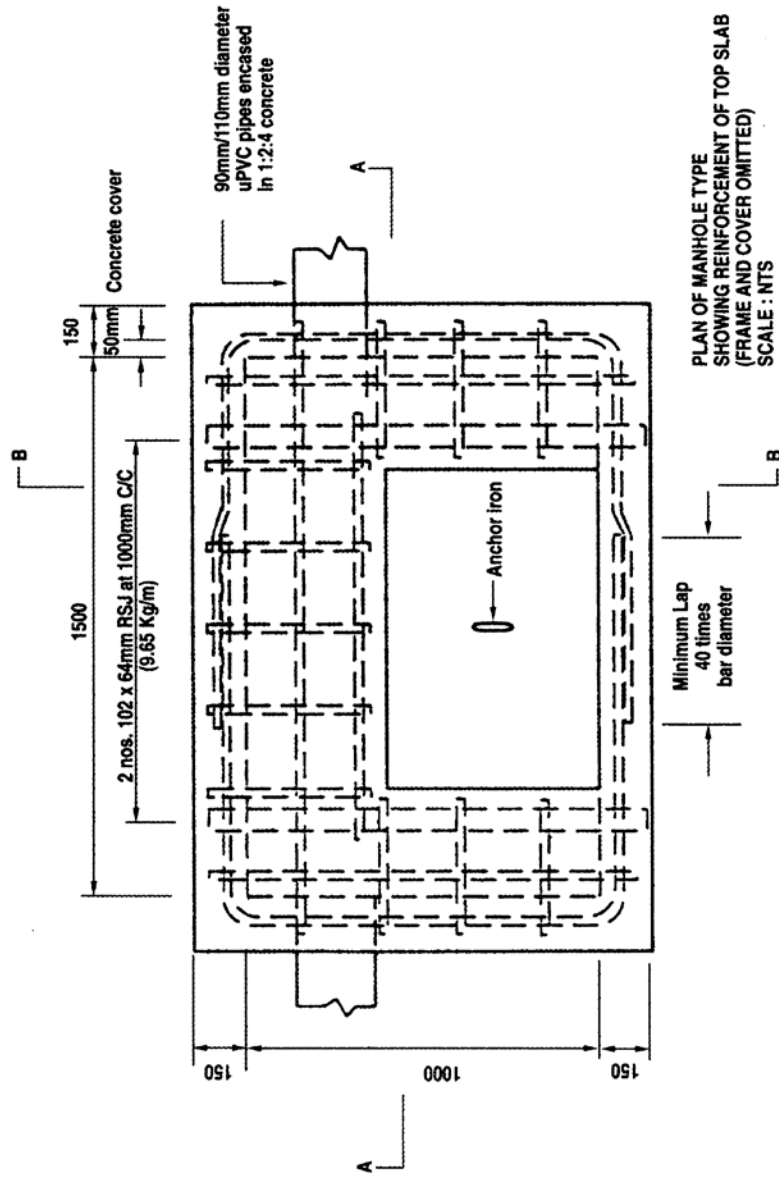

FIGURE 11.8: MANHOLE DRAWINGS - TYPE MX1

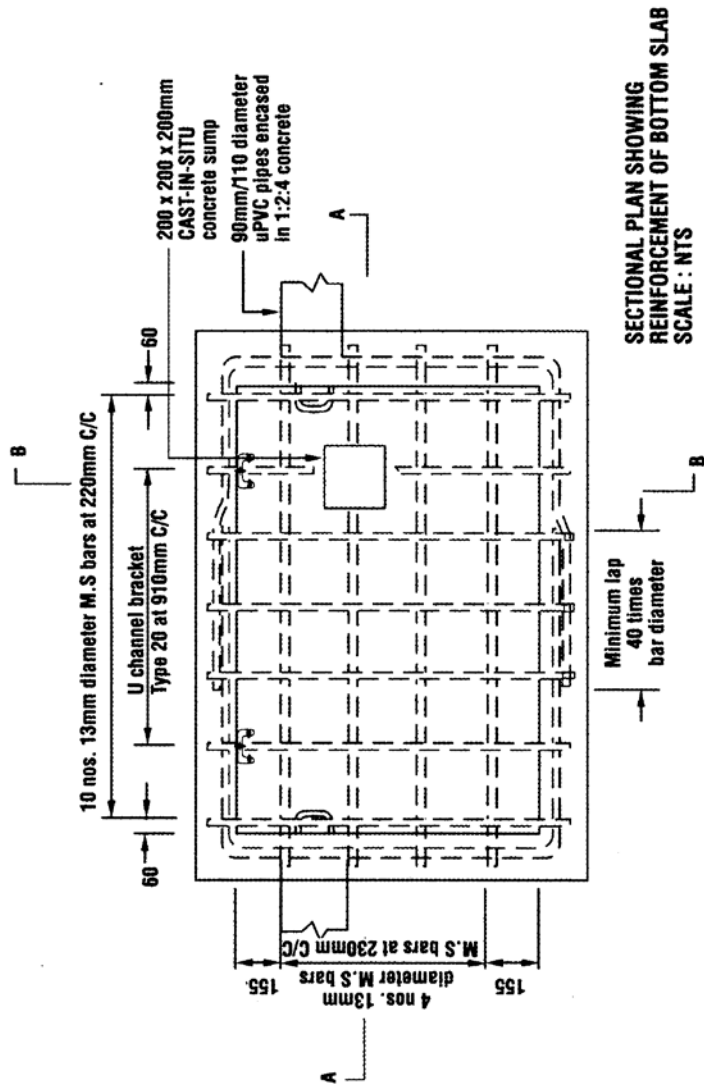

FIGURE 11.9: MANHOLE DRAWINGS - TYPE MX1

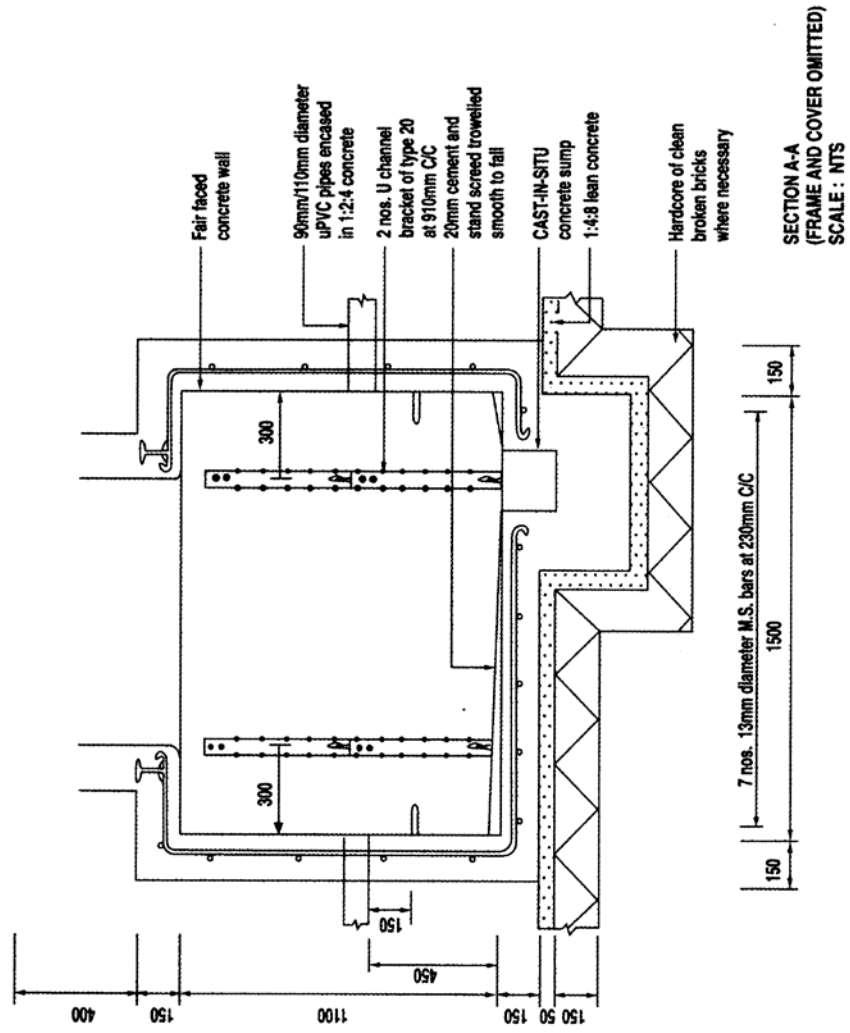
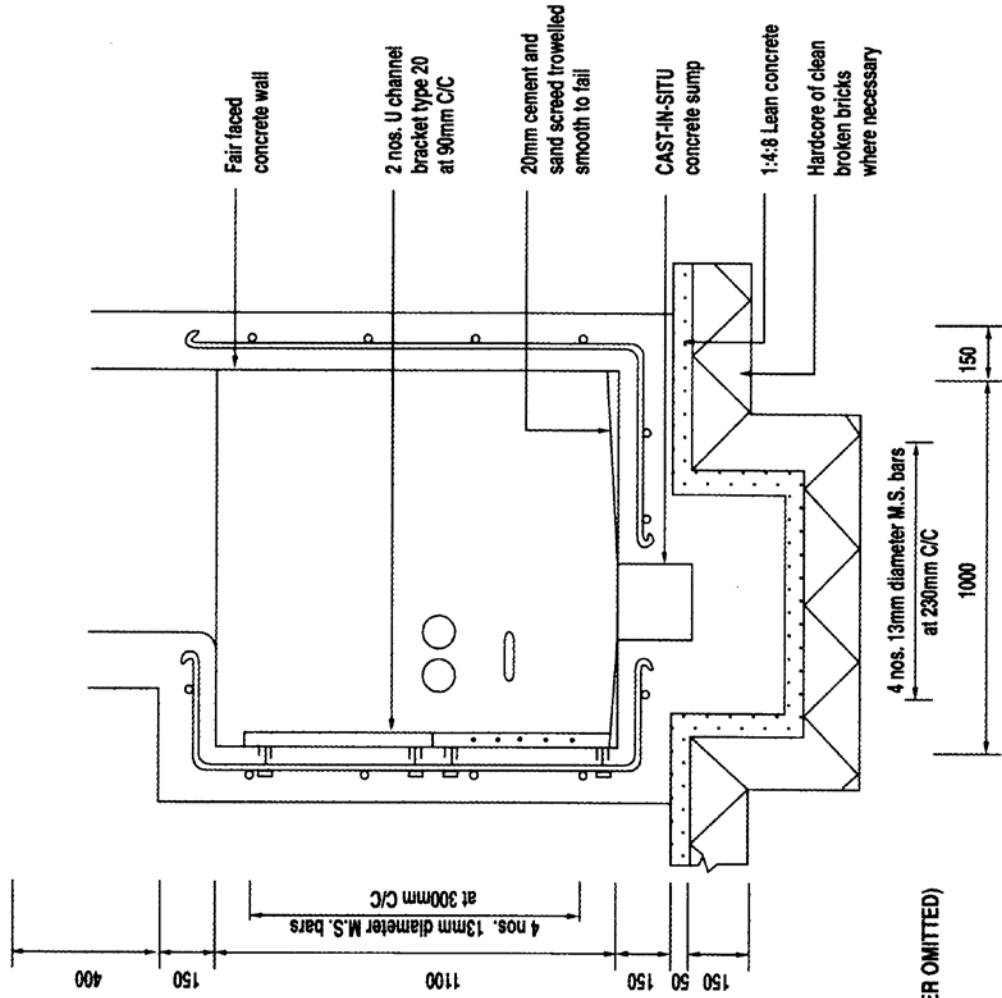

FIGURE 11.10: MANHOLE DRAWINGS - TYPE MX1



SECTION B-B
 (FRAME AND COVER OMITTED)
 SCALE : NTS

FIGURE 11.11: MANHOLE DRAWINGS - TYPE MX2

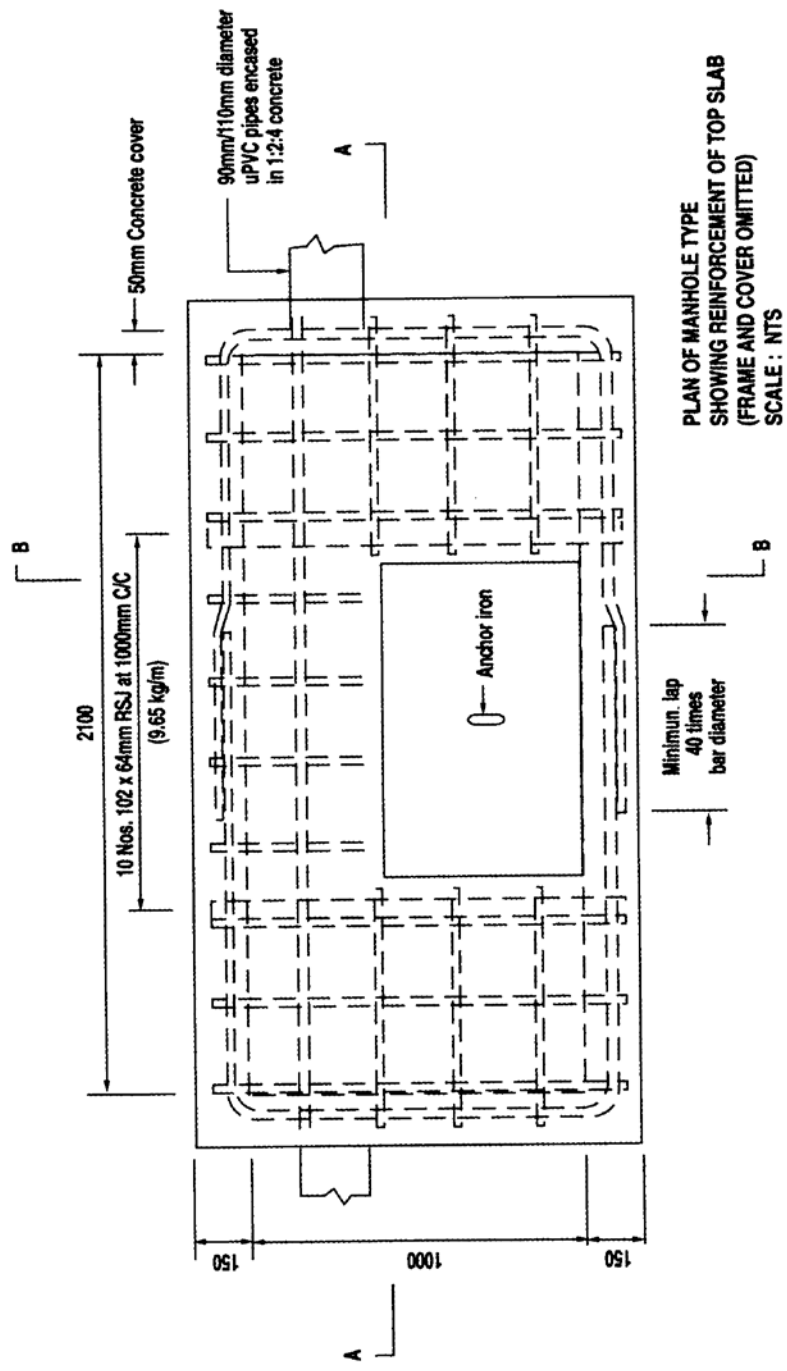
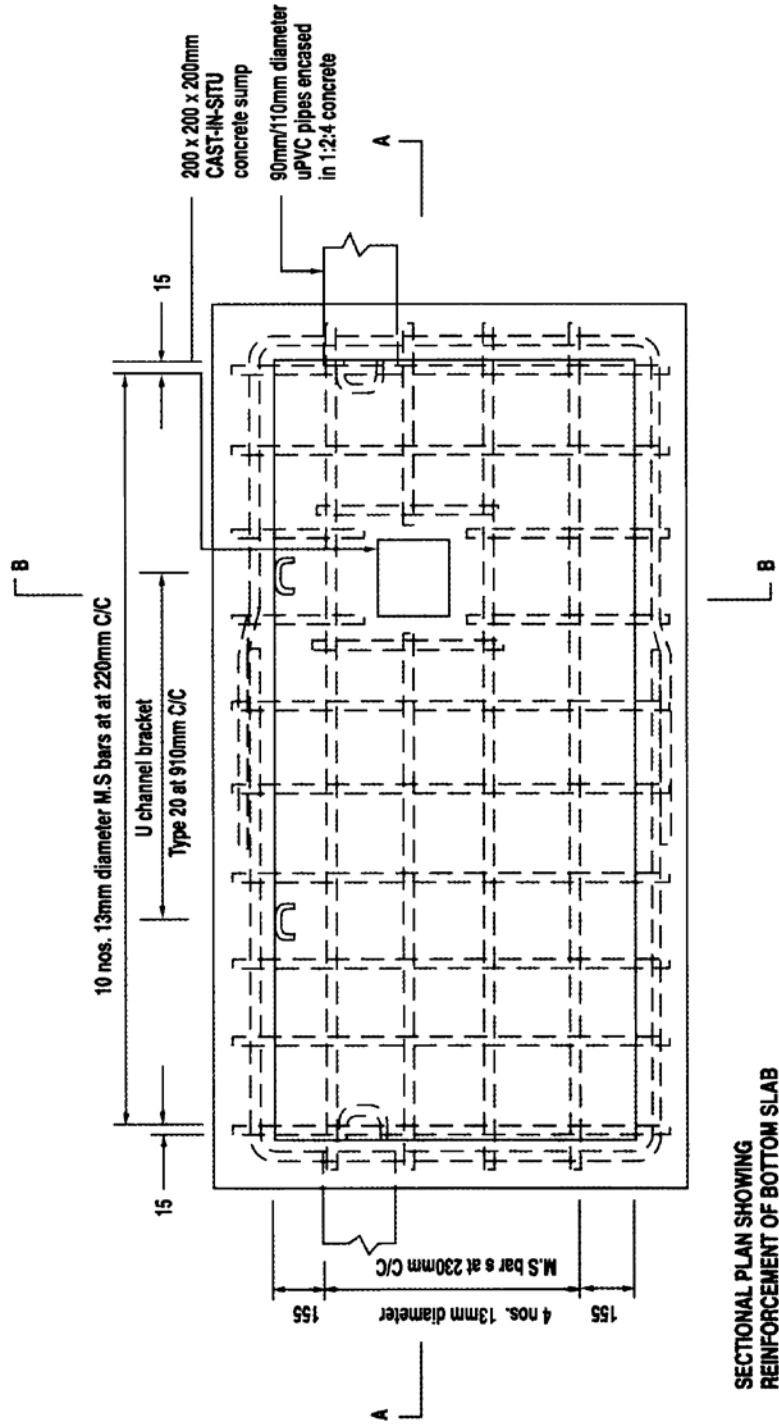

FIGURE 11.12: MANHOLE DRAWINGS - TYPE MX2



SECTIONAL PLAN SHOWING REINFORCEMENT OF BOTTOM SLAB
SCALE : NTS

FIGURE 11.13: MANHOLE DRAWINGS - TYPE MX2

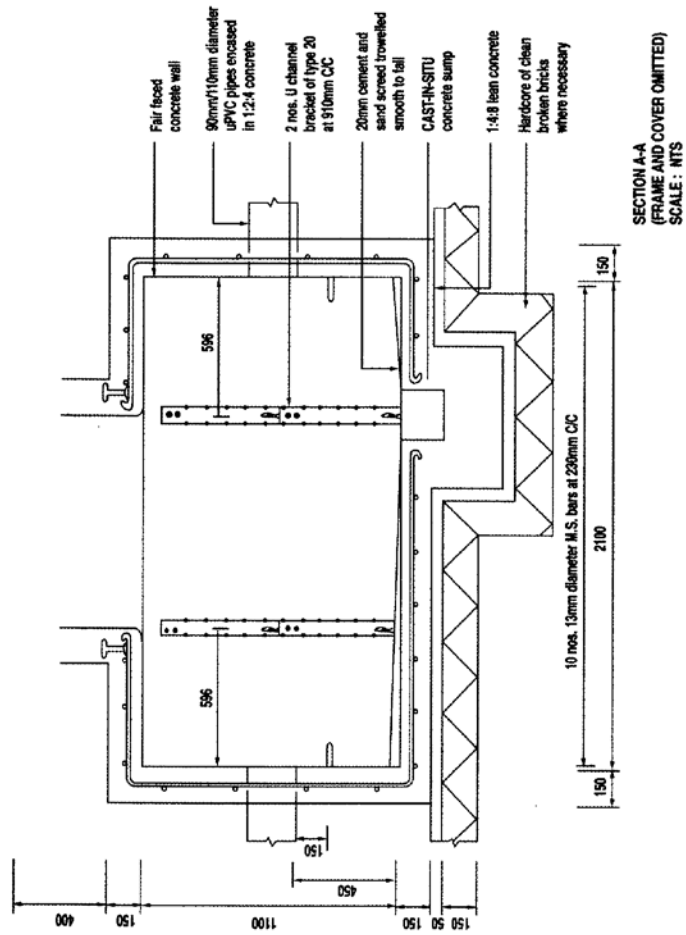
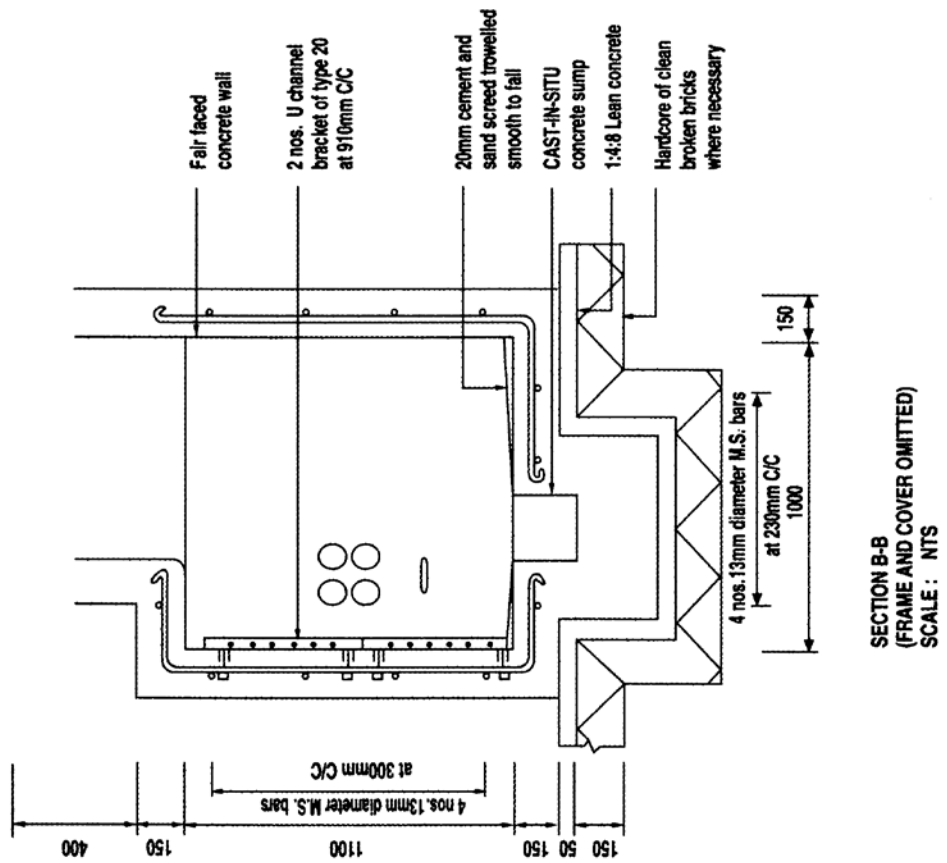

FIGURE 11.14: MANHOLE DRAWINGS - TYPE MX2



SECTION B-B
(FRAME AND COVER OMITTED)
SCALE: NTS

FIGURE 11.15: MANHOLE DRAWINGS - TYPE MX1 & MX2

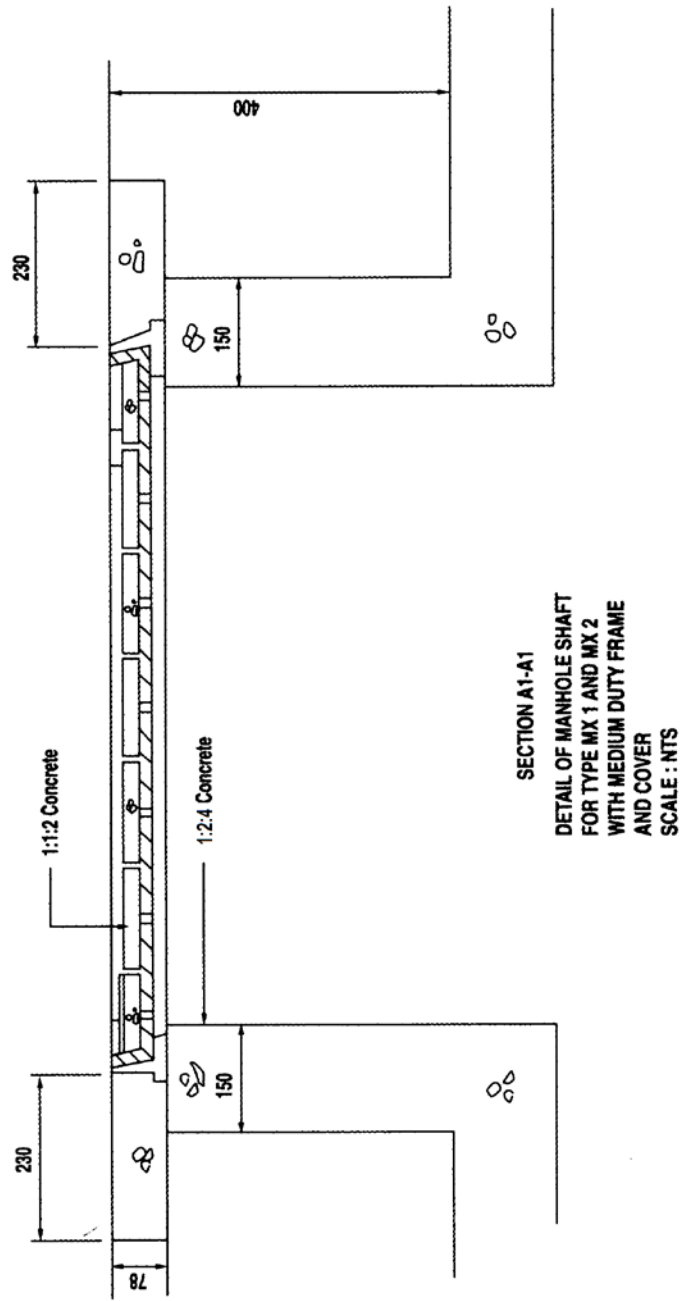

FIGURE 11.16: MANHOLE DRAWINGS - TYPE MX1 & MX2

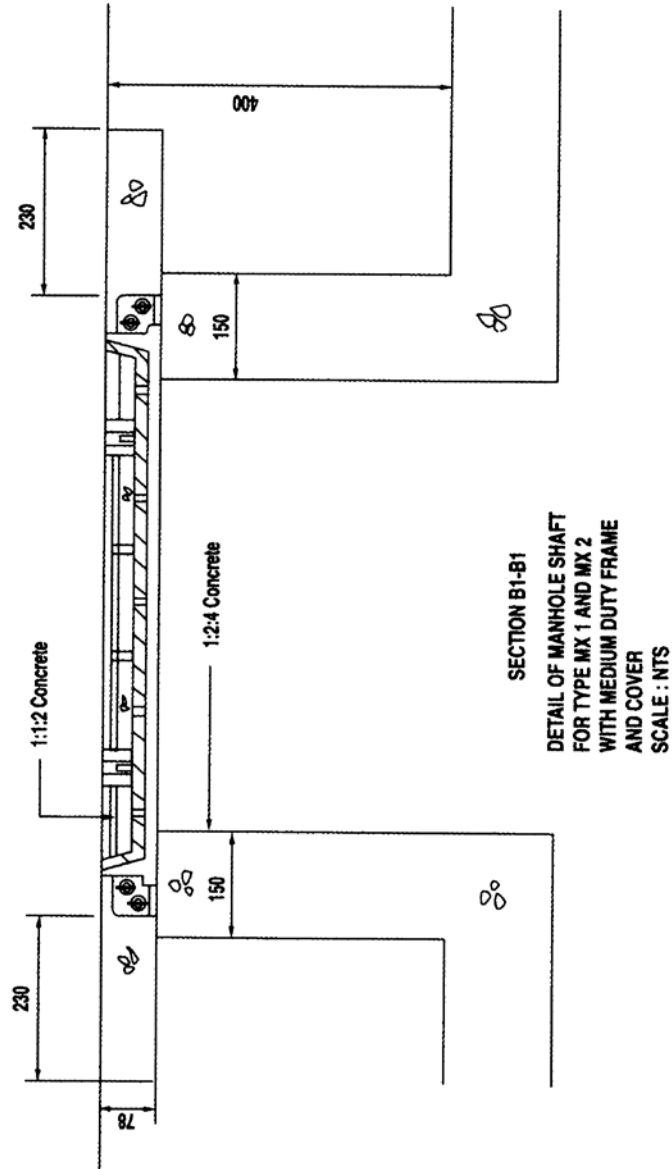
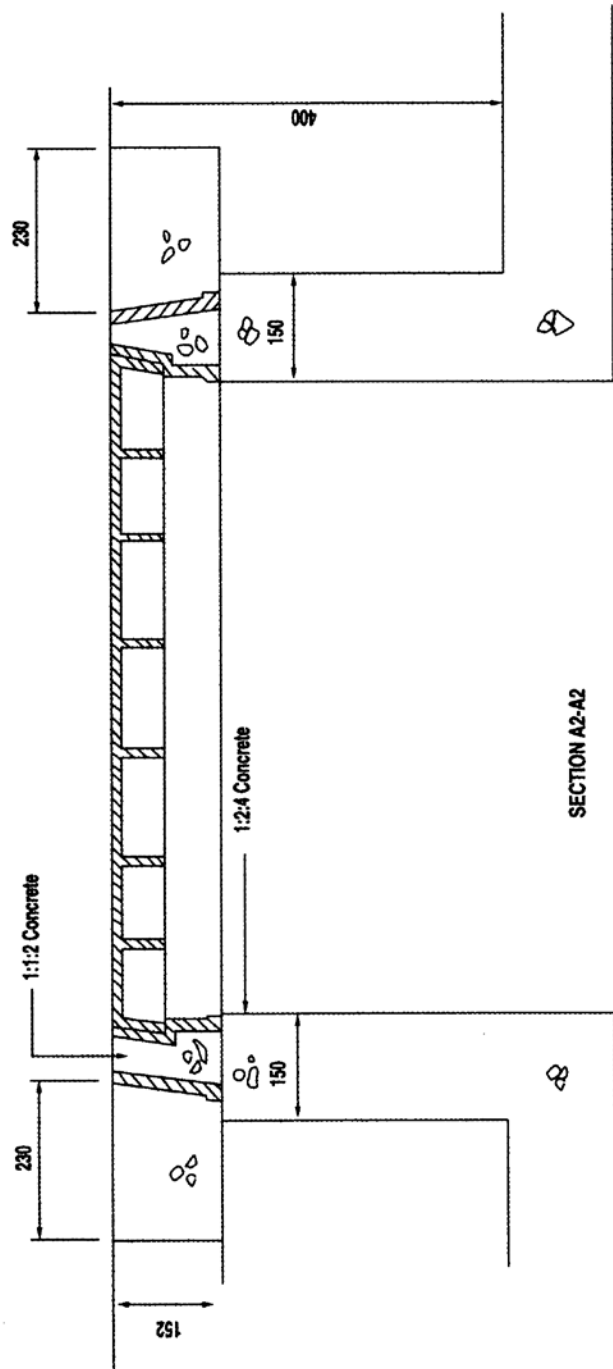

FIGURE 11.17: MANHOLE DRAWINGS - TYPE MX1 & MX2



SECTION A2-A2

DETAIL OF MANHOLE SHAFT
FOR TYPE MX 1 AND MX 2
WITH HEAVY DUTY FRAME
AND COVER COMPLIED WITH SS:30
SCALE: NTS

FIGURE 11.18: MANHOLE DRAWINGS - MX1 & MX2

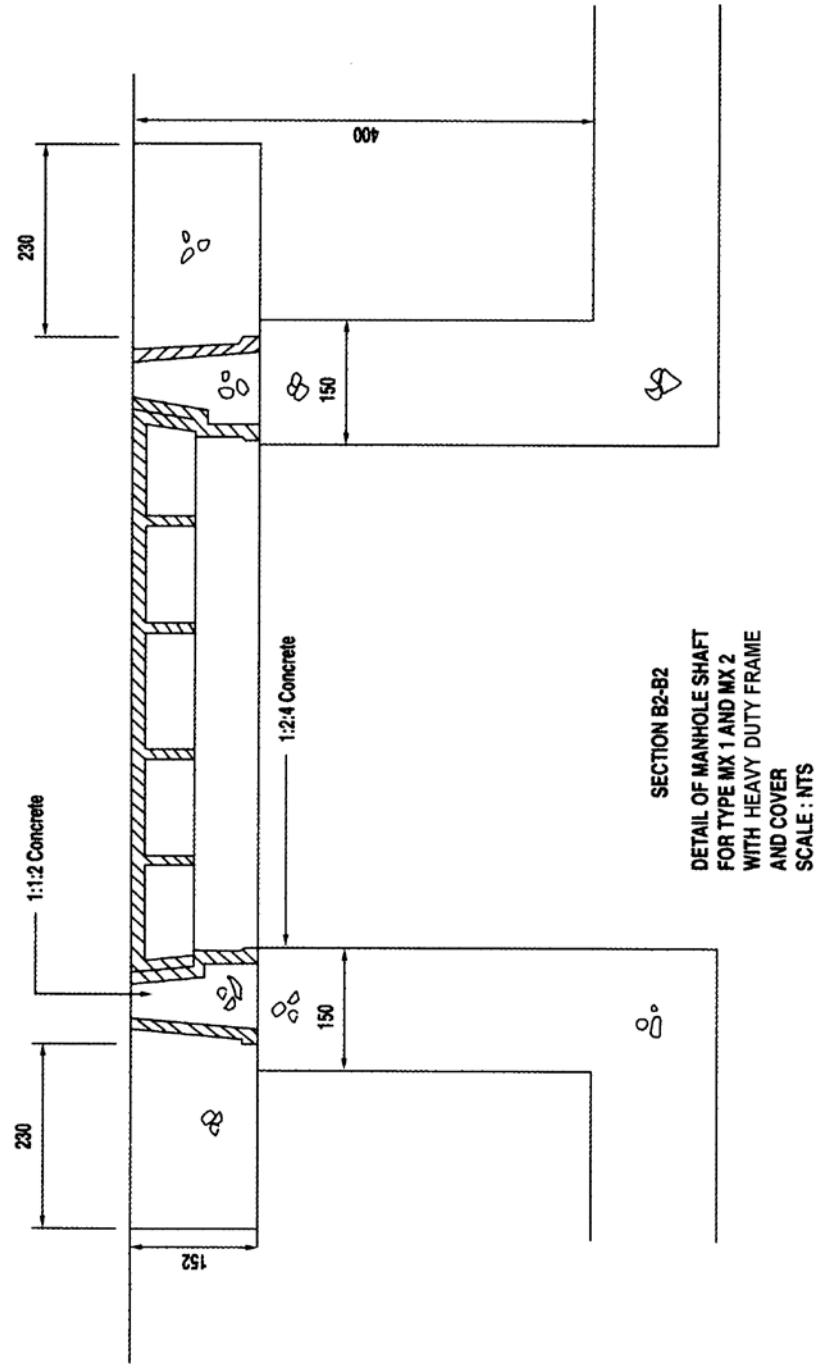

FIGURE 11.19: MANHOLE DRAWING - TYPE MX3

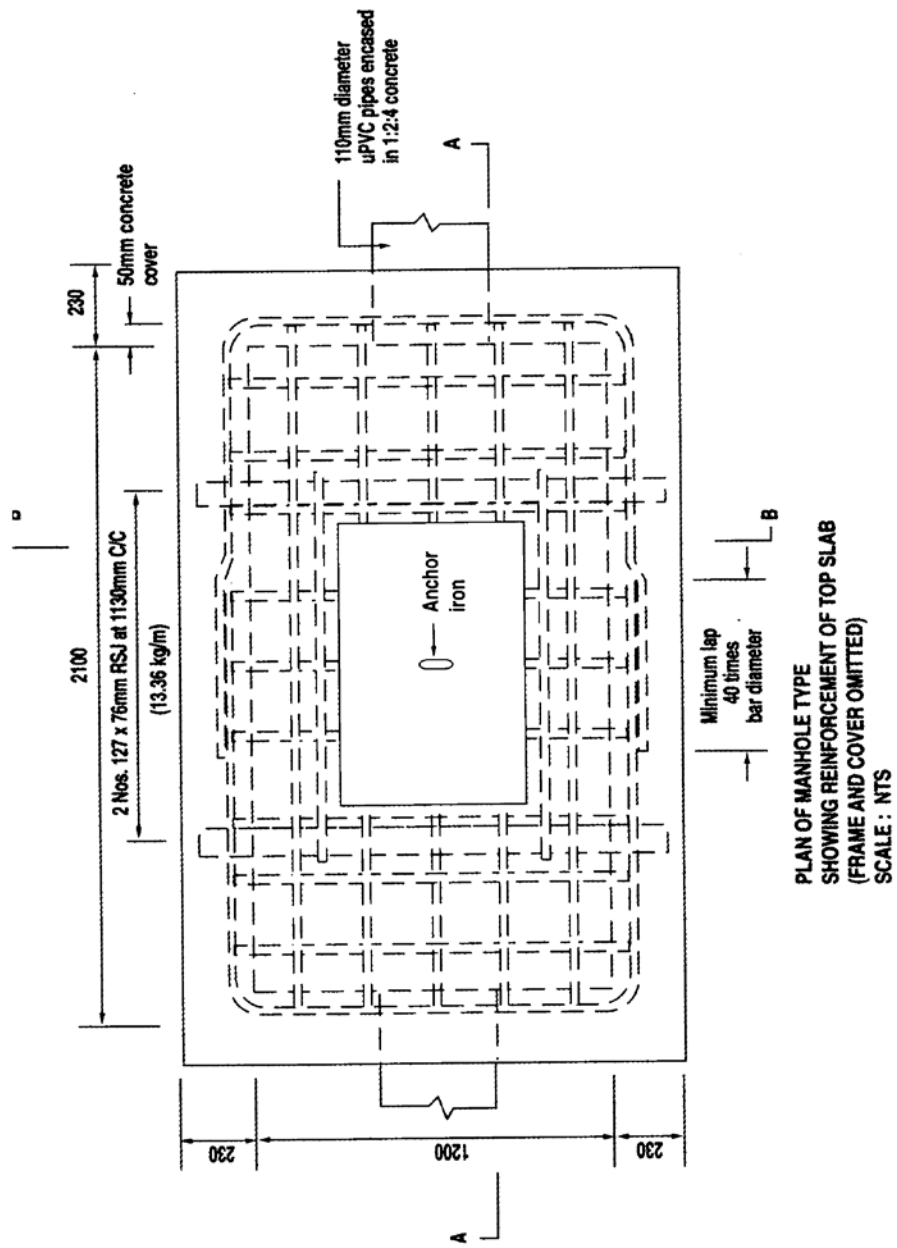

FIGURE 11.20: MANHOLE DRAWINGS - TYPE MX3

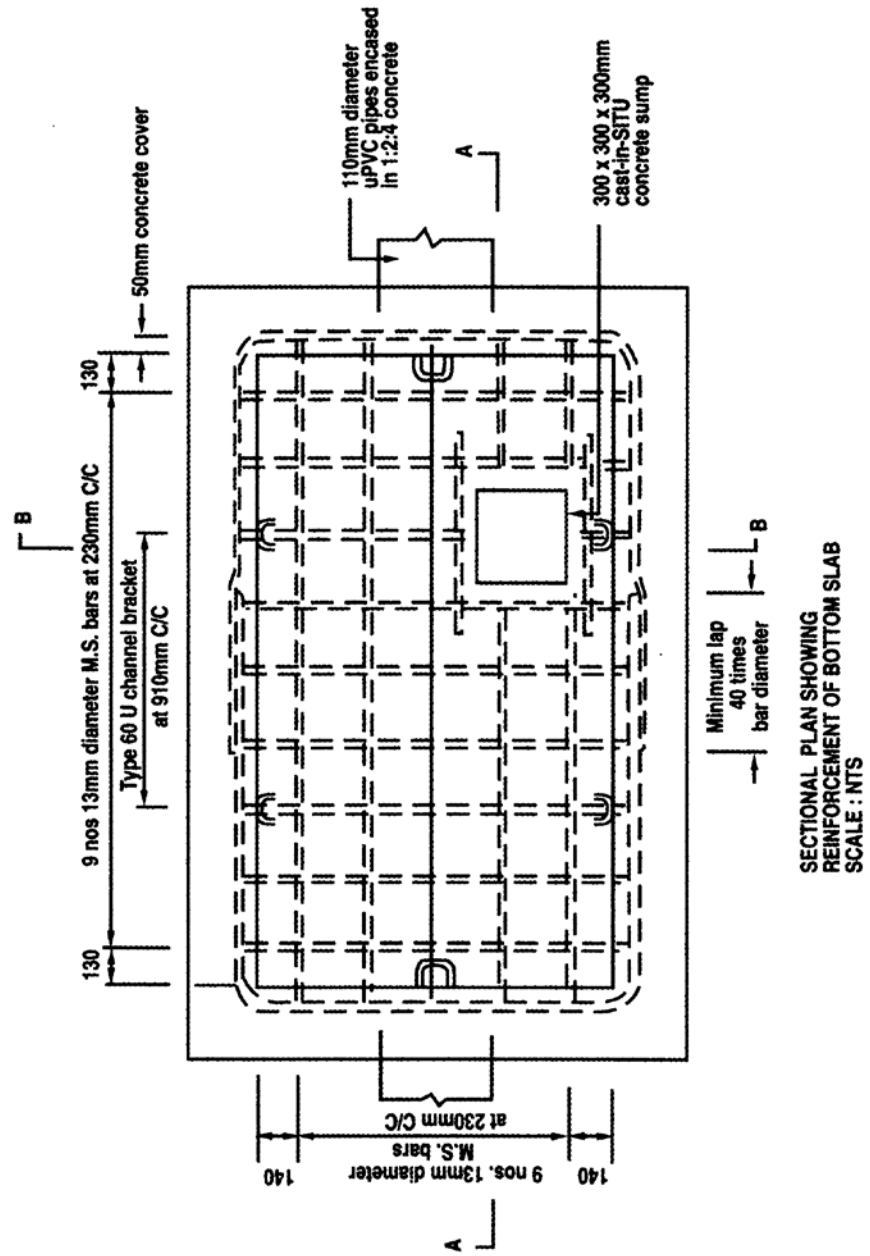

FIGURE 11.21: MANHOLE DRAWINGS - TYPE MX3

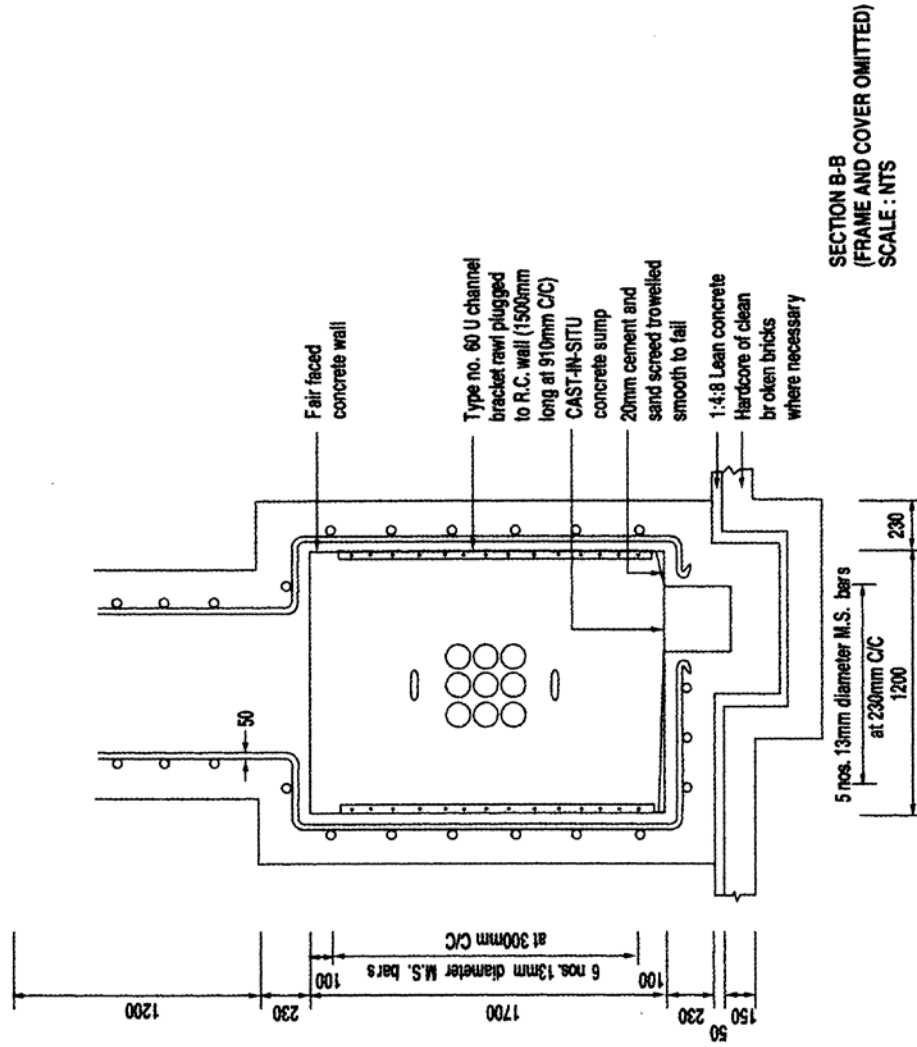
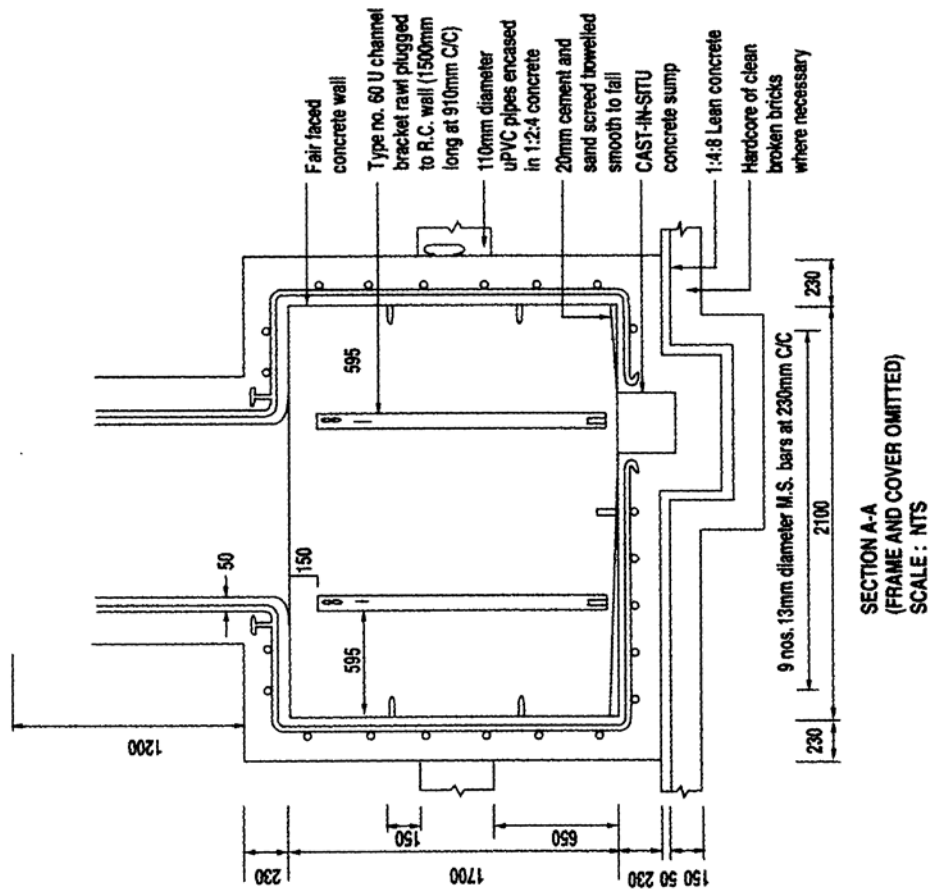

FIGURE 11.22: MANHOLE DRAWINGS - MX3



SECTION A-A
(FRAME AND COVER OMITTED)
SCALE : NTS

FIGURE 11.23: MANHOLE DRAWINGS - TYPE MX3 & ABOVE

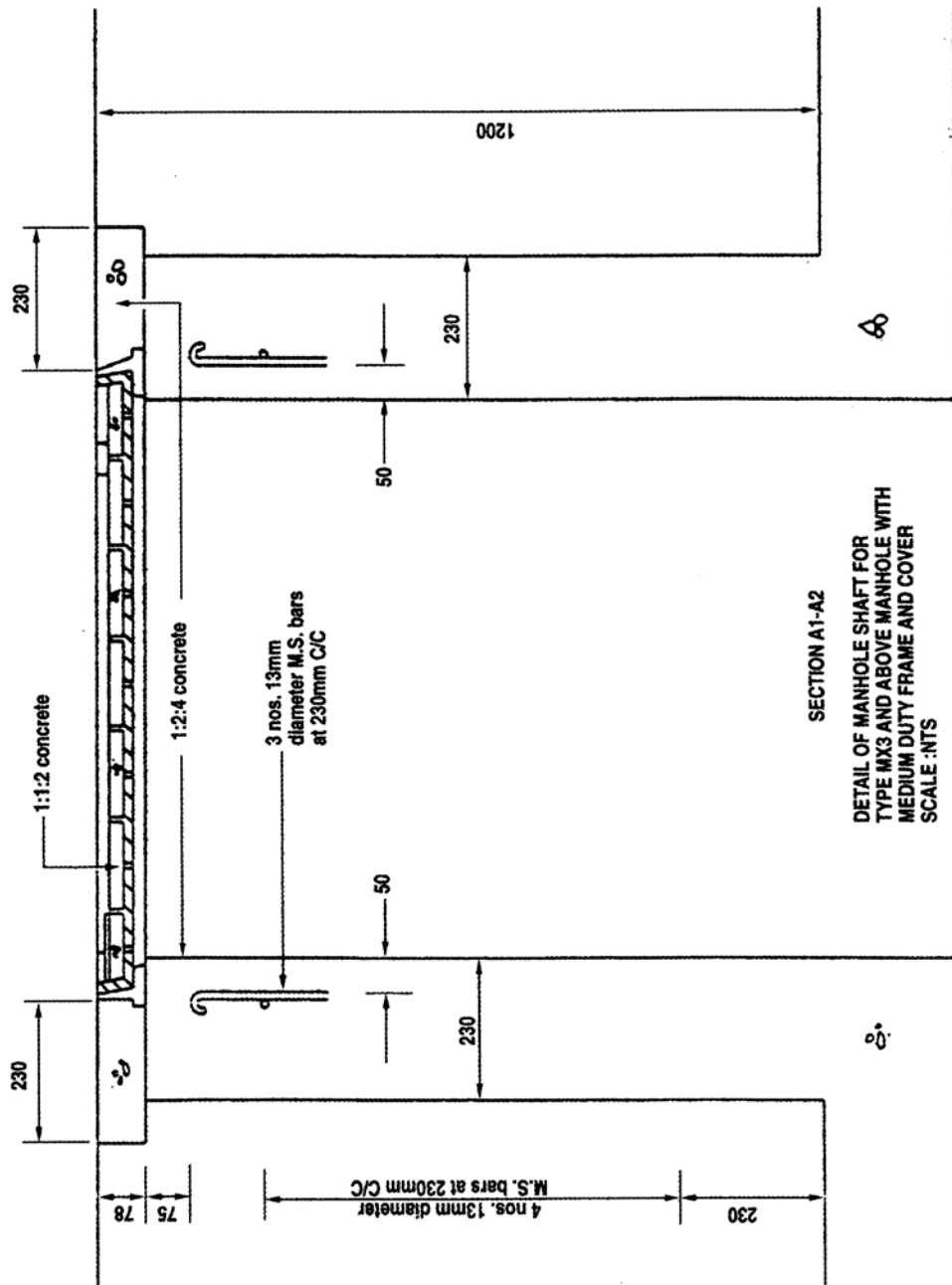

FIGURE 11.24: MANHOLE DRAWINGS - TYPE MX3 & ABOVE

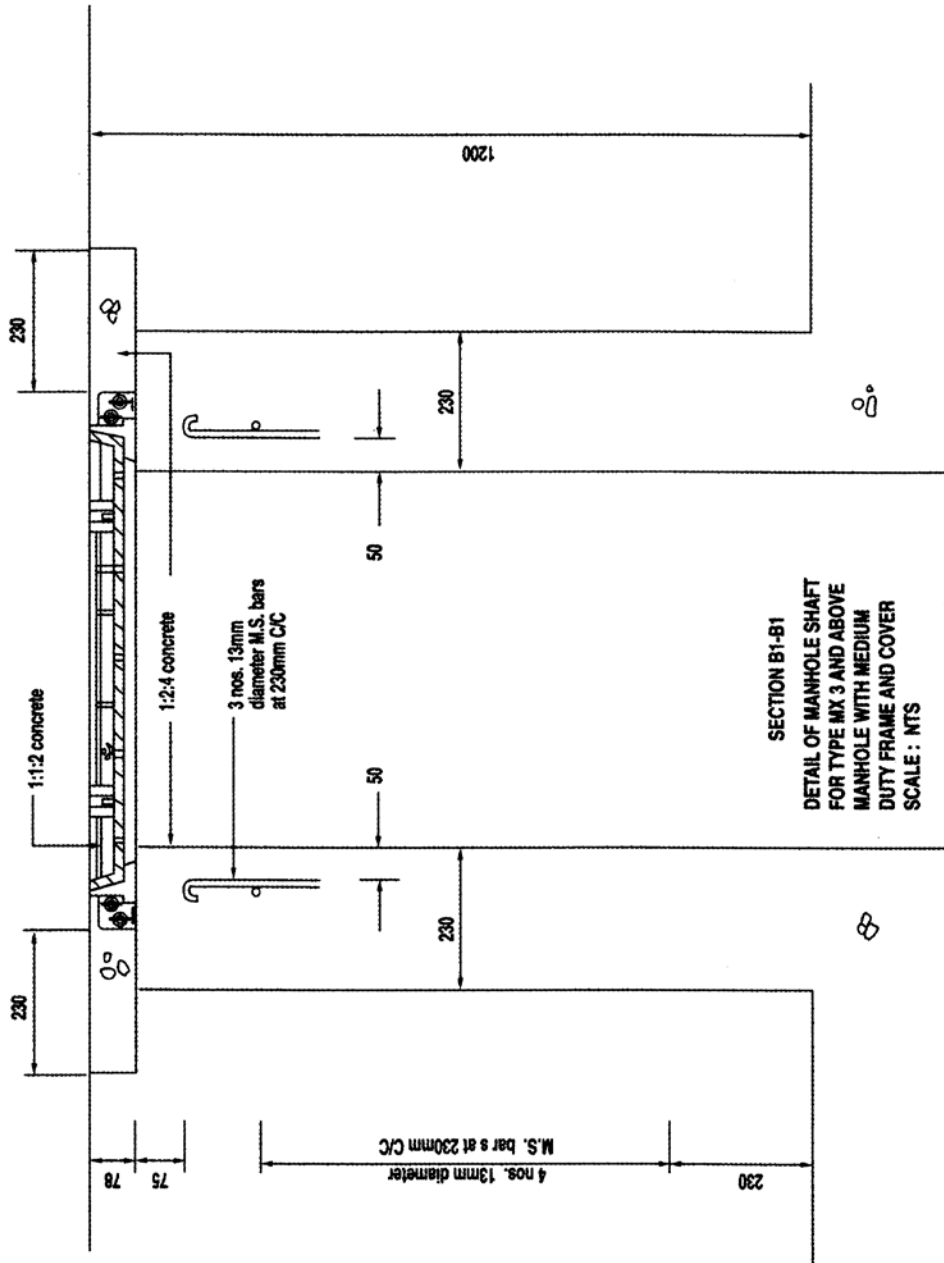

FIGURE 11 .25: MANHOLE DRAWINGS - TYPE MX3 & ABOVE

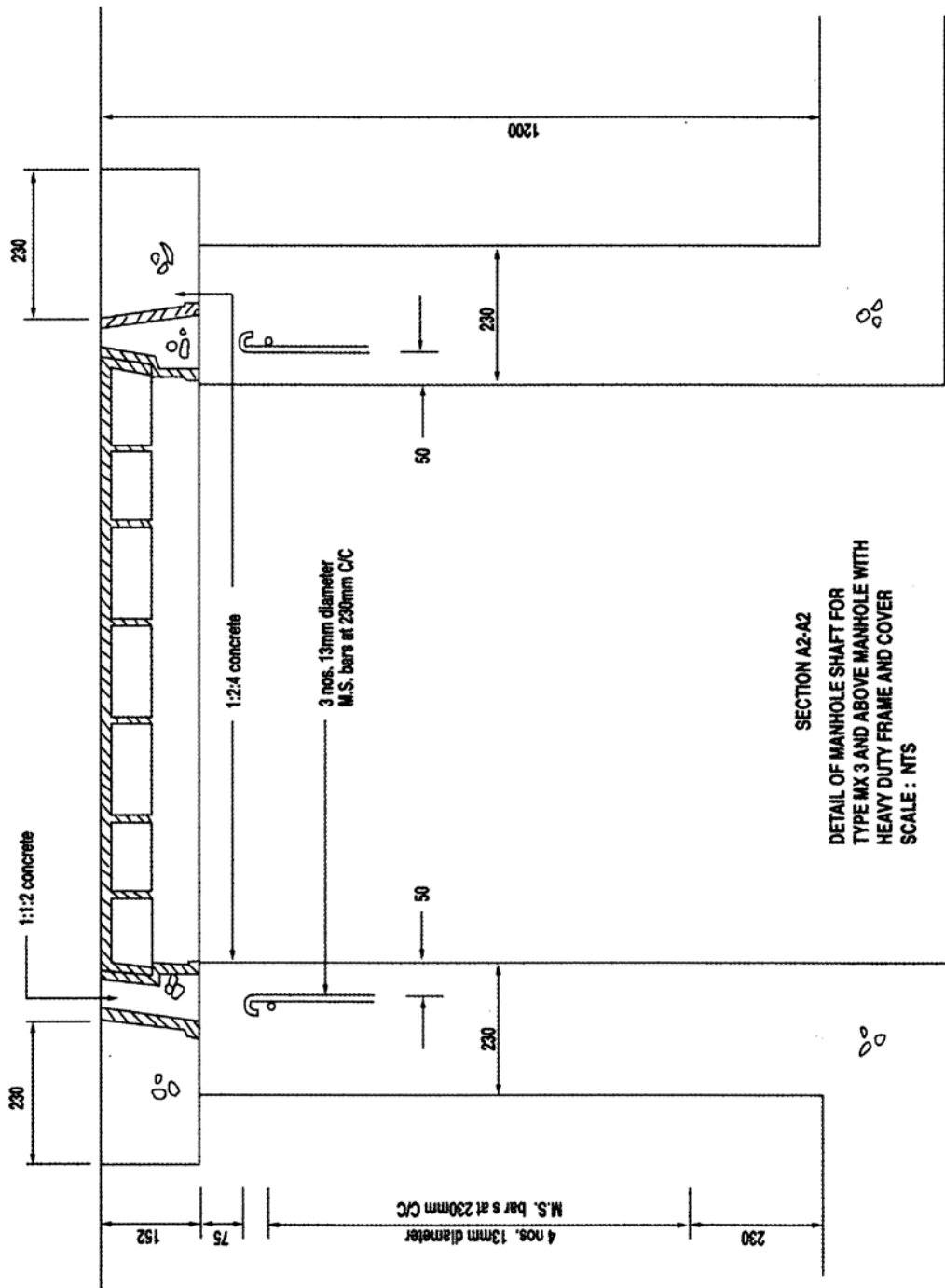

FIGURE 11.26: MANHOLE DRAWINGS - TYPE MX3 & ABOVE

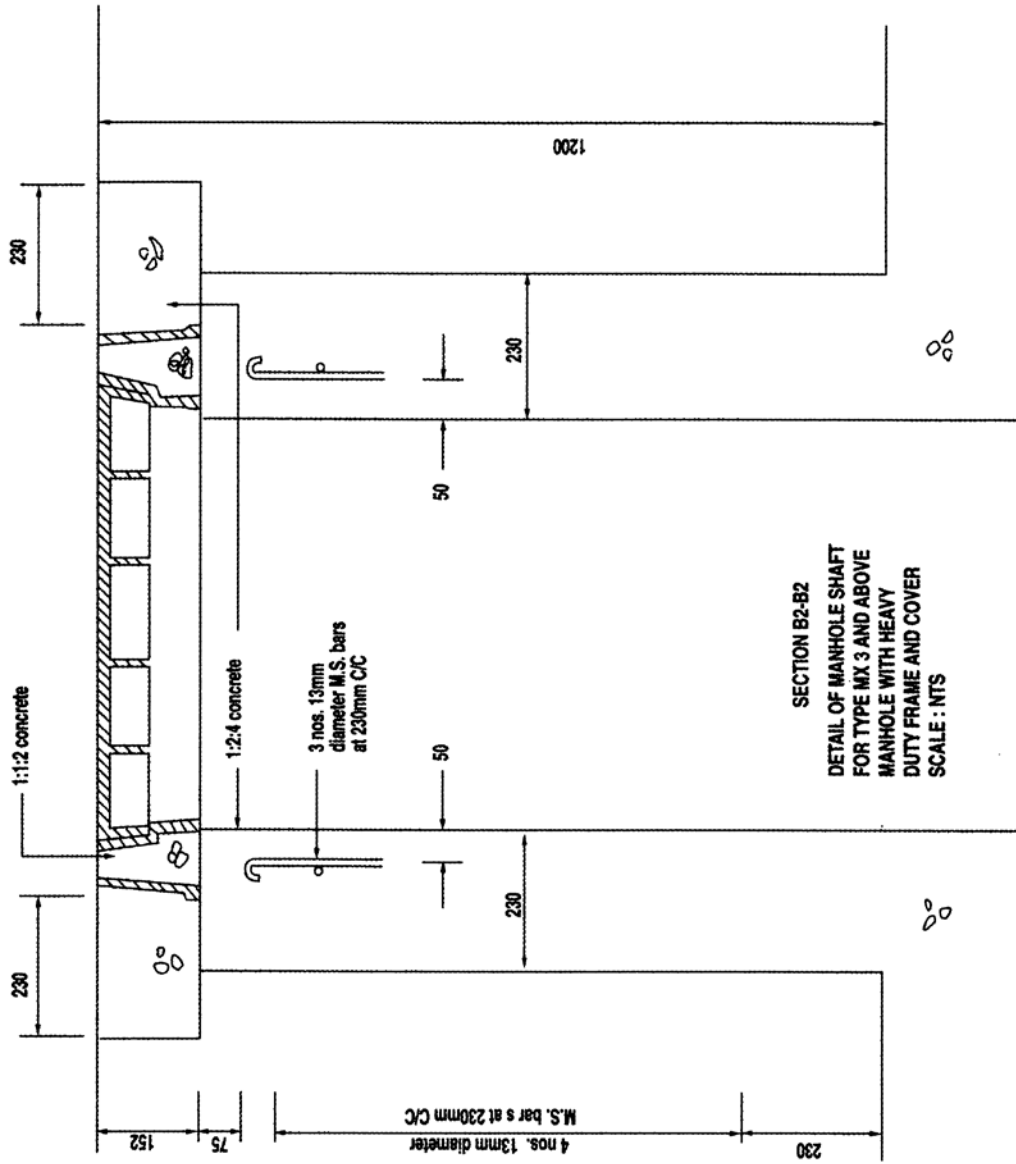
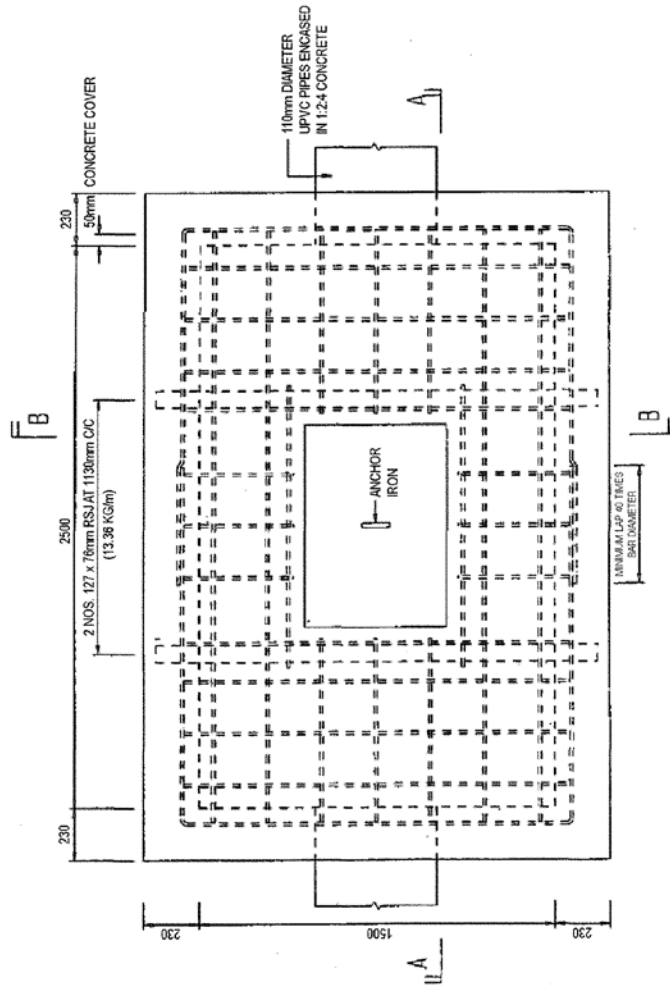
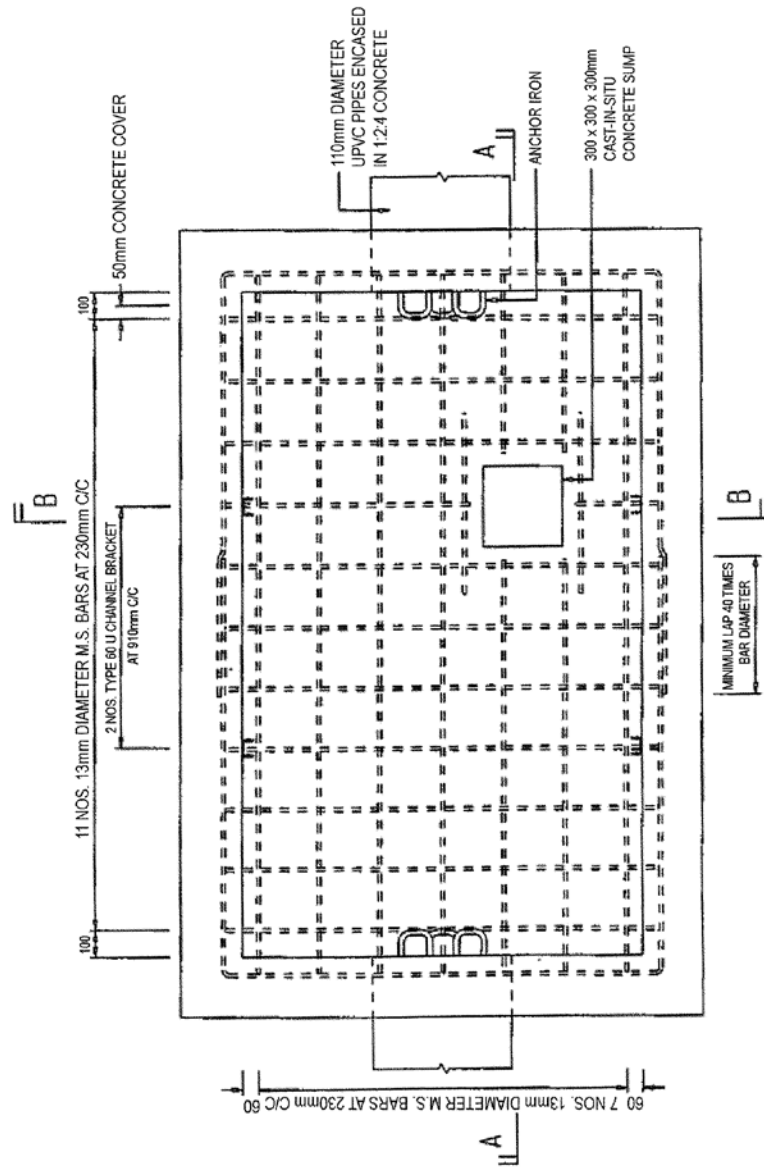

FIGURE 11.27: MANHOLE DRAWINGS - TYPE MX4



PLAN OF MANHOLE
SHOWING REINFORCEMENT OF TOP SLAB
(FRAME AND COVER OMITTED)
SCALE: NTS

FIGURE 11.28: MANHOLE DRAWINGS - TYPE MX4



SECTIONAL PLAN OF MANHOLE
 SHOWING REINFORCEMENT OF BOTTOM SLAB
 SCALE: NTS

FIGURE 11.29: MANHOLE DRAWINGS - TYPE MX4

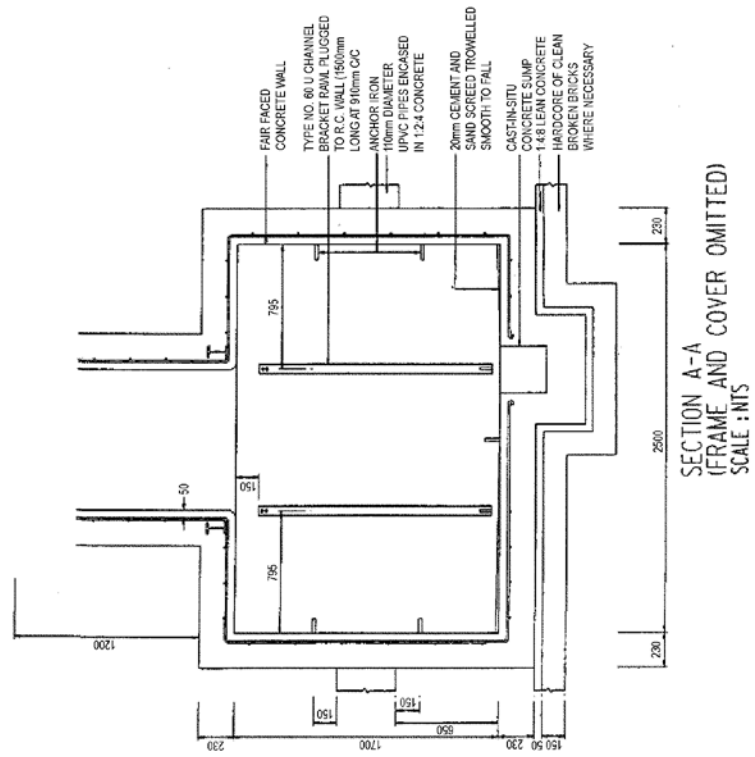
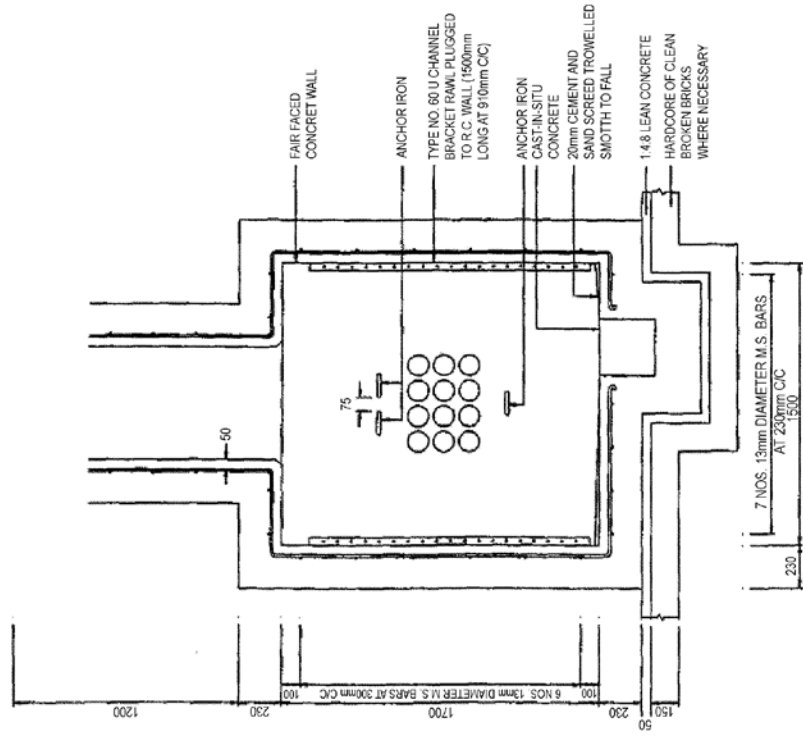
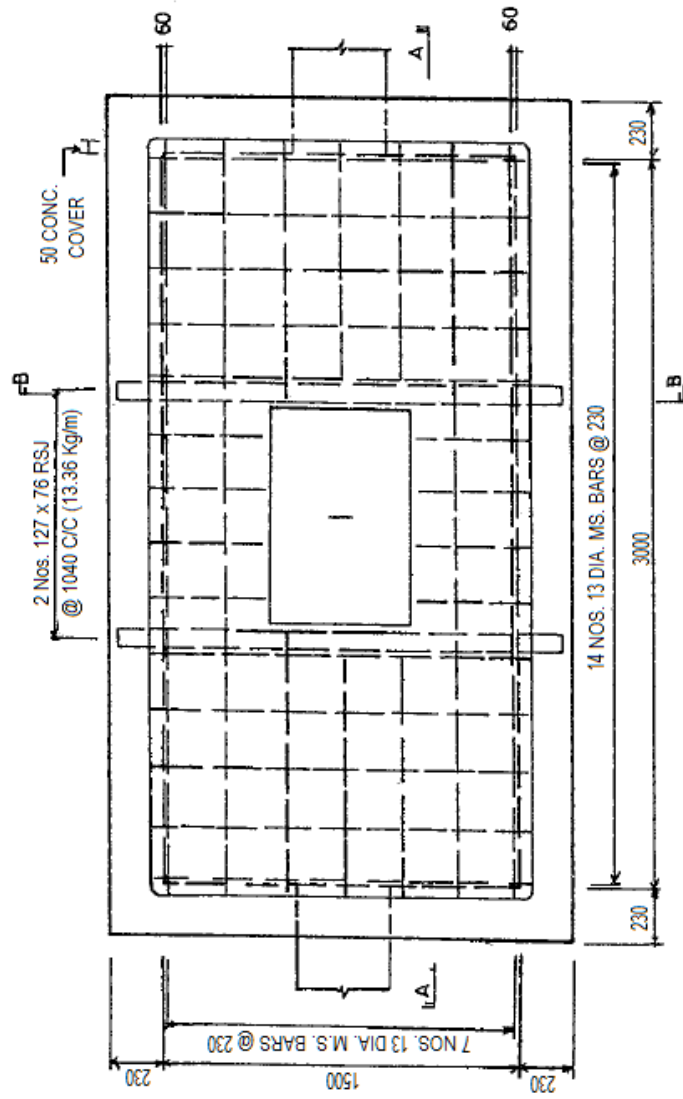

FIGURE 11.30: MANHOLE DRAWINGS - TYPE MX4



SECTION B-B
 (FRAME AND COVER OMITTED)
 SCALE : NTS

FIGURE 11.31: MANHOLE DRAWINGS - TYPE MX5 (DRAWING 1 OF 3)



PLAN SHOWING REINFORCEMENT OF TOP SLAB
 (FRAME AND COVER OMITTED)
 SCALE: NTS

FIGURE 11.32: MANHOLE DRAWINGS - TYPE MX5 (DRAWING 2 OF 3)

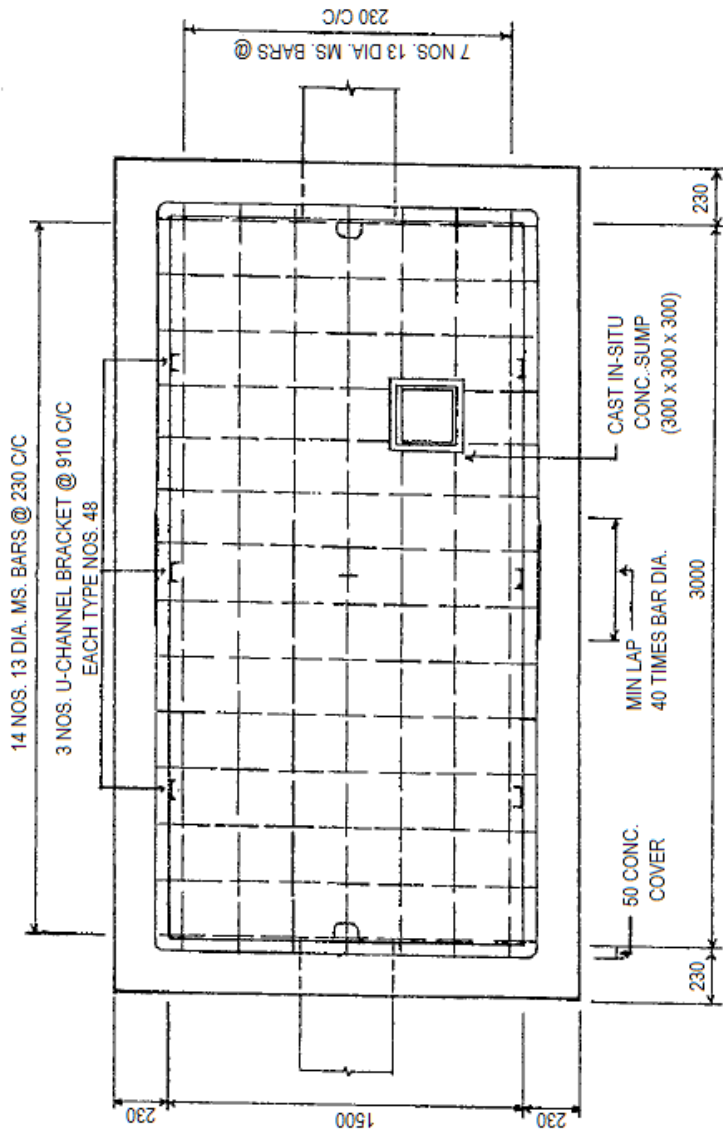

SECTIONAL PLAN SHOWING REINFORCEMENT OF BOTTOM SLAB
SCALE: NTS

FIGURE 11.33: MANHOLE DRAWING - TYPE MX5 (DRAWING 3 OF 3)

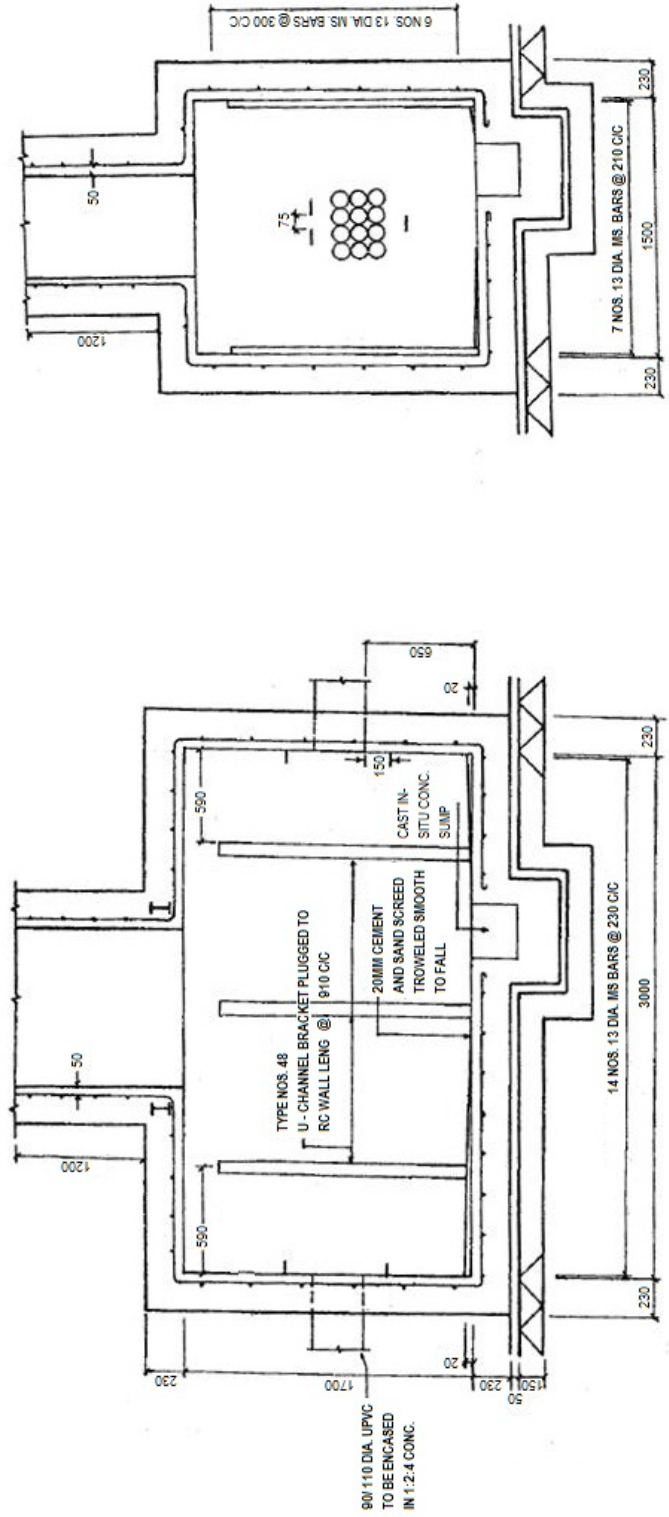
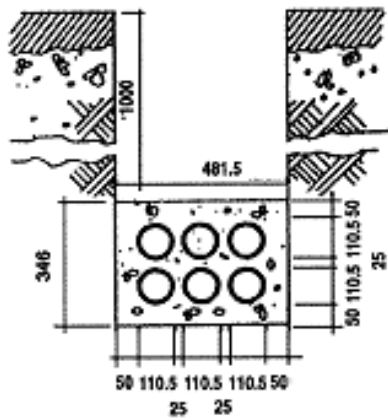
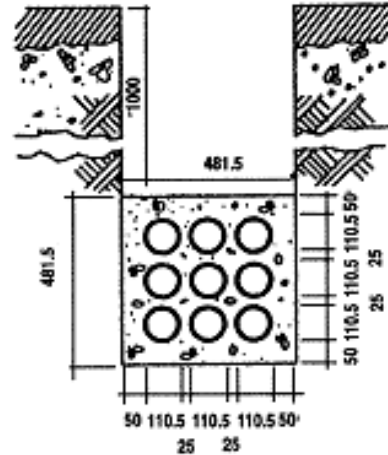

FIGURE 11.34: DRAWINGS OF MULTI-WAY PIPELINES (CONT'D)



SECTION
6 way pipe formation
DRAWING NO 1d



SECTION
9 way pipe formation
DRAWING NO 1e

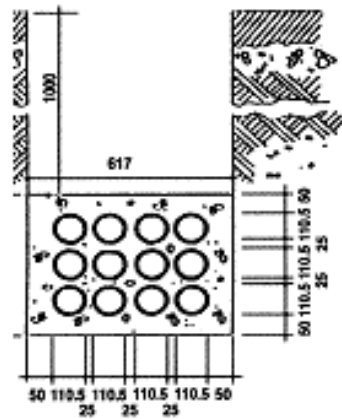

SECTION
12 Way pipe formation
DRAWING NO 1f

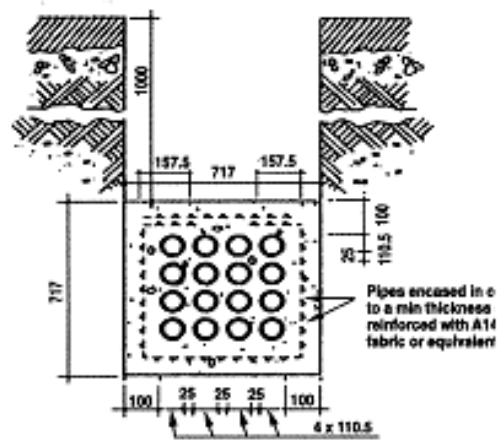

SECTION
16 Way pipe formation
DRAWING NO 1g

**FIGURE 11.34: DRAWINGS OF MULTI-WAY PIPELINES
(CONT'D)**

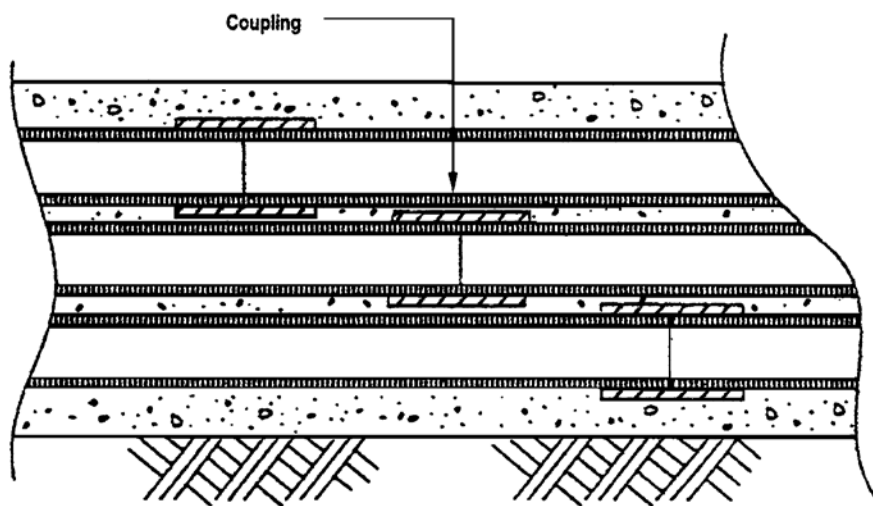

Detail showing staggered joints of
PVC applicable to all multiple ways

DRAWING NO 2

**FIGURE 11.34: DRAWINGS OF MULTI-WAY PIPELINES
(CONT'D)**

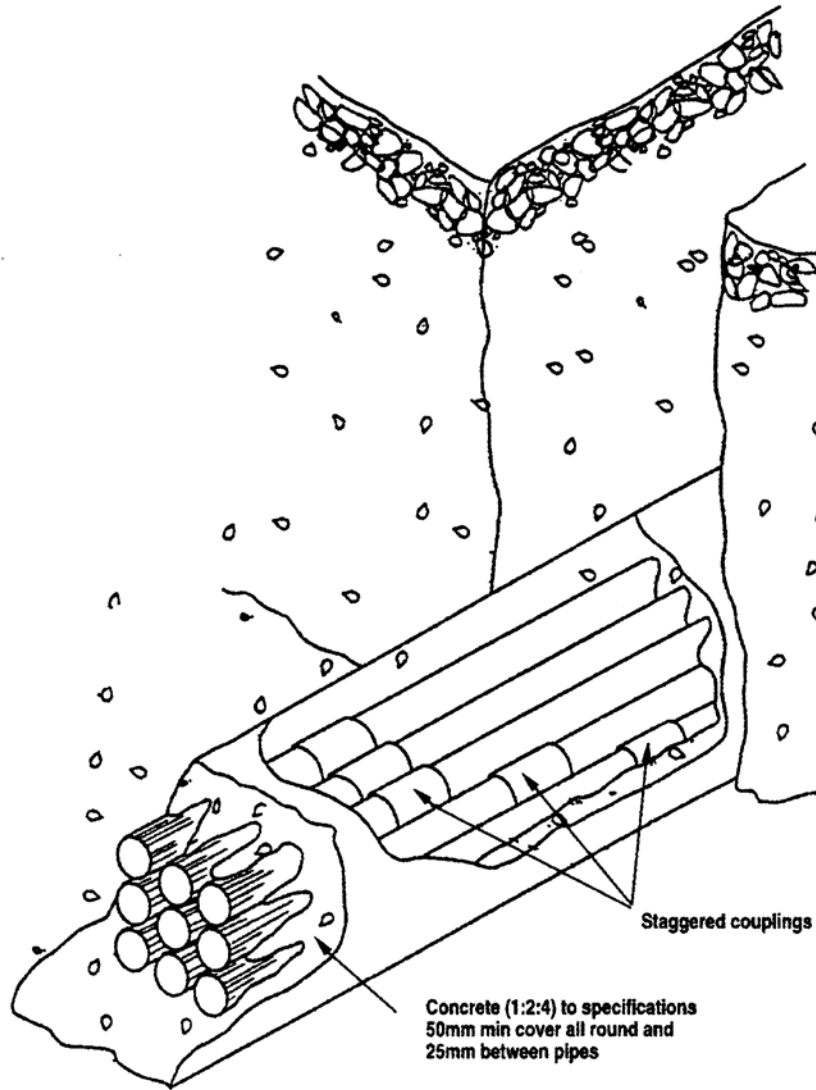

9 way pipe formation

DRAWING NO 3

**FIGURE 11.34: DRAWINGS OF MULTI-WAY PIPELINES
(CONT'D)**

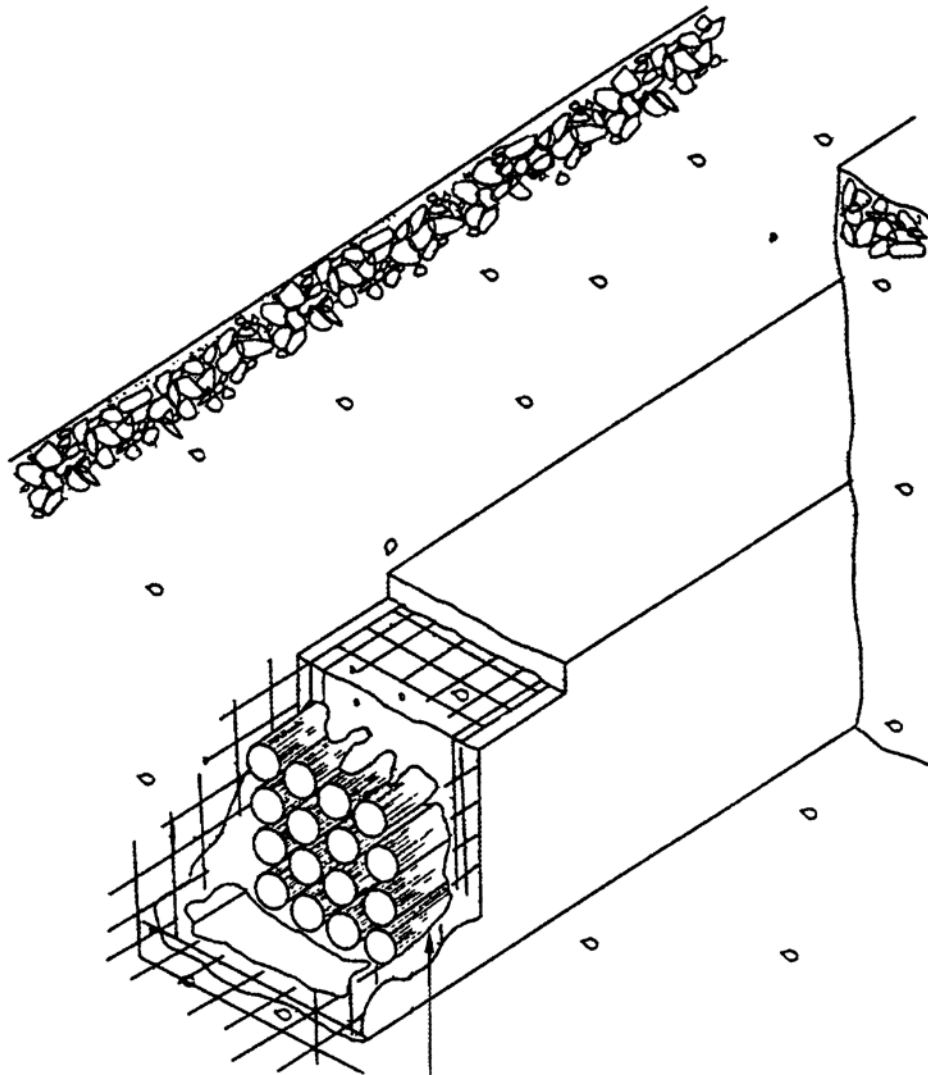

NOTES :

- 1) 16 Way pipe formation
- 2) All pipe formation exceeding 16 ways

Pipes encased in concrete (1:2:4) to a min thickness of 100mm reinforced with A142 steel fabric or equivalent

DRAWING NO 4

CHAPTER 12 MAIN DISTRIBUTION FRAME ROOM, TELECOMMUNICATION EQUIPMENT ROOM & MOBILE DEPLOYMENT SPACE

12.1 Overview

- 12.1.1 This chapter sets out the additional requirements for the provision of main distribution frame room, telecommunication equipment room and mobile deployment space.
- 12.1.2 IDA reserves the right to require any developer or owner to provide such rooms or spaces of larger size or additional main distribution frame rooms, telecommunication equipment rooms or mobile deployment spaces in those buildings where there is greater demand for telecommunication services, if such additional provision is necessary.

12.2 Location

- 12.2.1 Every developer or owner who is required to provide a main distribution frame room, telecommunication equipment room and/or mobile deployment space shall –
- (a) site the main distribution frame room, telecommunication equipment room and/or mobile deployment space as close as possible to the telecommunication risers;
 - (b) not site the main distribution frame room and/or telecommunication equipment room –
 - (i) in an area through which any system or network of water pipes, gas pipes or electrical trunking is running;
 - (ii) under any area that is susceptible to dampness or moisture such as a vehicle washing bay, swimming pool, washroom or toilet;
 - (iii) in any area which will subject the plant deployed therein to vibration of more than 0.05 G, where G is the acceleration due to gravity ($G=9.81 \text{ m/s}^2$); or
 - (iv) in any area where it will be directly subjected to the discharge of water, steam, fumes, gases or dust; and
 - (c) not site the mobile deployment space –
 - (i) in any area which will subject the plant deployed therein to vibration of more than 0.05 G, where G is the acceleration due to gravity ($G=9.81 \text{ m/s}^2$);
 - (ii) in any area where it will be directly subjected to the discharge of water, steam, fumes, gases or dust;
 - (iii) in any area within or near the bin centre; or

- (iv) in any area where the concrete floor is not able to withstand a loading of 1.5kN/m^2 or more.

12.3 Construction

12.3.1 Every developer or owner who is required to provide a main distribution frame room and/or telecommunication equipment room shall –

- (a) construct the room using reinforced concrete or brick wall;
- (b) finish the surface of the room with cement plaster and ensure that it is free of cracks, blisters or other defects;
- (c) paint the walls of the room with a light colour paint;
- (d) ensure that the room is of a minimum height of 3.5m (measured from the floor to the ceiling) throughout the entire room save that where it is not practicable to provide a minimum height of 3.5m, the developer or owner shall provide a cable ladder from the lead-in pipes which is to –
 - (i) run vertically to a height of at least 2.5m and subsequently run horizontally to all sides of the walls of the room with a height clearance of at least 300mm from any obstruction above it; and
 - (ii) have a width which is similar to the collective width of all the pipes entering the room;
- (e) finish the floor of the room with vinyl tiles or screed;
- (f) ensure that the concrete floor of the room is able to withstand a loading of 480kg/m^2 ;
- (g) ensure that all doors of the room open outwards fully;
- (h) ensure that the door frames for the doors of the room have a 100mm high concrete skirting/kerb to prevent the ingress of water;
- (i) where the cable tray enters the room from the floor, ensure that the floor opening has a width that is not more than 1.25 times the width of the cable tray and a depth of not more than 200mm; and
- (j) where the cable tray enters the room from the floor, construct the floor opening with a kerb around the opening, extending vertically upwards and adjoining the opening, with a height of 100mm and a thickness of 50mm.

12.3.2 Where the developer or owner provides a main distribution frame room in the form of a standalone structure, such developer or owner shall, in addition to the requirements specified in paragraph 12.3.1, ensure that –

- (a) the floor of the main distribution frame room is at least 150mm above the immediate external final road or driveway level;

- (b) the floor of the main distribution frame room is waterproofed;
- (c) the walls of the main distribution frame room are waterproofed;
- (d) the emulsion painting system used for the outside wall of the main distribution frame room is suitable for external application;
- (e) the ceiling of the main distribution frame room is smoothly finished and emulsion painted;
- (f) the roof of the main distribution frame room is constructed of flat reinforced concrete, suitably waterproofed and constructed to a fall of approximately 1:80 away from the direction of the door;
- (g) proper drainage is provided around the main distribution frame room such as hinged hot-dipped galvanised mild steel gratings;
- (h) where applicable, the gate and perimeter fencing is of a minimum height of 1.8m;
- (i) the driveway to the main distribution frame room is of a minimum width of 4m and designed to withstand a minimum vehicular load of a 3-tonne vehicle; and
- (j) all vacant space from the main distribution frame room to the perimeter fencing is paved using tarmac or weld-mesh reinforced concrete with fall designed for quick dispersion of water to the surrounding drains.

12.4 Ventilation and air-conditioning

12.4.1 Every developer or owner of a non-residential building who is required to provide a main distribution frame room shall provide for ventilation of the main distribution frame room by way of:

- (a) air-conditioning from the central system (where central air-conditioning system is provided in the relevant development), provided that the developer or owner shall:
 - (i) ensure that the temperature in the main distribution frame room is $22^{\circ}\text{C} \pm 2^{\circ}\text{C}$;
 - (ii) ensure that the relative humidity in the main distribution frame room is $< 70\%$; and
 - (iii) prior to issuance of the temporary occupation permit for the relevant building, seal all the underground pipes at the point of entry into the main distribution frame room, with a material that is durable, can be easily removed, and will not cause damage to the underground pipes and any telecommunication cable that may be used in the underground pipes, such that no foreign gaseous matter (which may be toxic or flammable) will pass through the underground pipes into the main distribution frame room; or

- (b) louvres on the wall above the door, along the whole of that side of the wall, of the main distribution frame room, and where it is necessary to further ventilate the room, the developer or owner shall install exhaust fans at the top corners of the main distribution frame room.

12.4.2 Every developer or owner of a residential building who is required to provide a main distribution frame room and/or telecommunication equipment room shall –

- (a) provide louvres on the wall above the door, along the whole of that side of the wall, of the main distribution frame room and/or telecommunication equipment room; and
- (b) where it is necessary to further ventilate the room, install exhaust fans at the top corners of the main distribution frame room and/or telecommunication equipment room.

12.5 Electrical

12.5.1 Every developer or owner who is required to provide a main distribution frame room and/or telecommunication equipment room shall –

- (a) provide electrical mains to the main distribution frame room and/or telecommunication equipment room from the main electrical distribution panels which shall be successfully tested by qualified persons licensed or certified by the competent authority or electricity company; and
- (b) ensure that the mean lighting illuminance in the main distribution frame room and/or telecommunication equipment room is at least 450 lux at floor level.

12.6 Earthing

12.6.1 Every developer or owner who is required to provide a main distribution frame room and/or telecommunication equipment room shall –

- (a) ensure that the earthing point is connected to the earth electrode system via earth cable with a cross section area of not less than 50mm²;
- (b) ensure that the copper earth bar has screw holes that are spaced 50mm apart measured from centre to centre; and
- (c) place the certified test result of the earth system together with actual layout diagrams showing the earth system arrangement in the main distribution frame room and/or telecommunication equipment room.

CHAPTER 13 TELECOMMUNICATION RISERS

13.1 Overview

13.1.1 This chapter sets out the additional requirements for the provision of telecommunication riser.

13.2 General requirements

13.2.1 Every developer or owner who is required to provide telecommunication risers shall -

- (a) provide a single-leaf door (the width of which shall be in accordance with the requirements set out in the relevant chapters in this Code) that can be opened fully outwards and is approximately 2.1m in height, on the width side of each telecommunication riser on every floor;
- (b) if the width of the riser exceeds 1.1m, provide a double-leaf door (the width of which shall be in accordance with the requirements set out in the relevant chapters in this Code) that can be opened fully outwards and is approximately 2.1m in height, on the width side of each telecommunication riser on every floor;
- (c) ensure that the fire-rating of the doors and compartment walls of the telecommunication risers complies with the requirements of the relevant authorities;
- (d) provide a 100mm high concrete skirting or kerb behind the doors of the telecommunication risers;
- (e) ensure that a label with the words "Telecoms Riser" with appropriate numbering for identification purpose is affixed to the door of the telecommunication riser on every floor;
- (f) provide adequate lighting to enable licensees to carry out their installation and maintenance work in the telecommunication risers;
- (g) ensure that the dimensions of the inter-floor openings in the telecommunication risers are as follows (and as shown in Figure 13.4):
 - (i) the width of the inter-floor opening shall be equivalent to 1.25 times the width of the cable trays; and
 - (ii) the depth shall be between 180mm to 220mm;
- (h) ensure that the inter-floor openings for the telecommunication risers are sealed with fire resistant material (as shown in Figure 13.4), which can be easily removed, in compliance with the Code of Practice for Fire Precautions in Buildings issued by Singapore Civil Defence Force (the "Sealing Obligation") no earlier than one month prior to the expected date of issuance of the temporary occupation permit (the "Due Date"), regardless whether the licensees have completed the installation of

their cables by the Due Date. For the avoidance of doubt, licensees who install their cables after the developer or owner has completed the sealing of inter-floor openings, will have to remove the seal and re-seal the inter-floor openings at their own cost;

- (i) ensure that the concrete floor in the telecommunication riser (as shown in Figure 13.4) is able to withstand the same loading as the floor outside the riser;
- (j) ensure that the walls of the telecommunication risers are smoothly plastered and painted with a light colour;
- (k) where non-coaxial cables are laid from the tenant or residential units in the building to the telecommunication risers, ensure that such cables are terminated at the appropriate termination or distribution boxes located in the telecommunication risers;
- (l) where broadband coaxial cable system cables are laid from the residential or tenant units in the building to the telecommunication risers, ensure that such cables are terminated into an amplifier (where applicable) or the taps/splitters located in the telecommunication risers; and
- (m) ensure that the internal wiring to all units is performed strictly by licensed telecommunication wiring contractors.

13.3 Internal wiring schedule

13.3.1 Every developer or owner who provides internal wiring shall –

- (a) prominently display an internal wiring schedule in the main distribution frame room indicating the unit numbers of the tenants or residential units to be served by the applicable telecommunication riser;
- (b) ensure that the internal wiring schedule is in the format shown in Table 13.3.1 below; and

Table 13.3.1 Internal wiring schedule

Telecom riser number	Address of unit served

- (c) extend a copy of the internal wiring schedule to licensees upon their request.

13.4 Placement of cables in telecommunication riser

Every developer or owner who is required to provide telecommunication riser shall ensure that the cables and associated cabling facilities for non-coaxial cables and coaxial cables are placed on opposite side walls of the telecommunication riser as shown in Figure 13.4 below.

FIGURE 13.4: TYPICAL LAYOUT IN TELECOMMUNICATION RISER

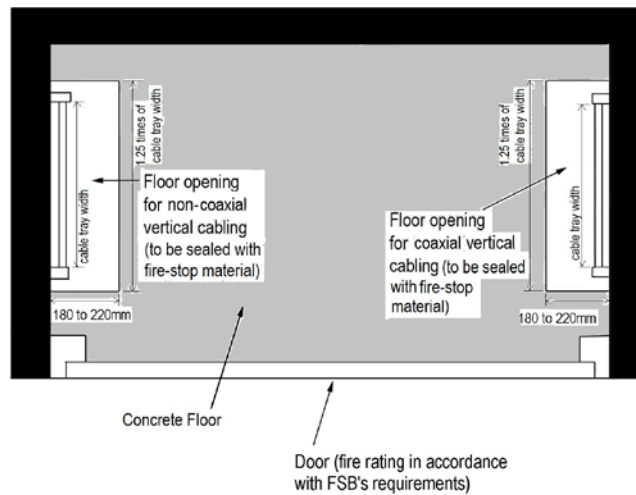

SCALE: NTS

CHAPTER 14 REQUIREMENTS FOR PROPER INSTALLATION OF A BROADBAND COAXIAL CABLE SYSTEM

14.1 General

- 14.1.1 This chapter sets out the requirements for the erection, cabling, safety, and performance requirements of a broadband coaxial cable system.
- 14.1.2 This chapter also provides detailed technical specifications relating to the proper installation, safety and performance of a broadband coaxial cable system for buildings that are to be interconnected to a licensee's broadband coaxial cable system.
- 14.1.3 Based on the requirements specified in this chapter, there should not be any significant wiring change when the building's broadband coaxial cable system is interconnected to a licensee's broadband coaxial cable system. However, the developer or owner may be required to install additional passive and active devices such as filters, decoders, reverse signal path amplifiers, interdiction equipment, etc, in order to keep abreast of technological changes and new technical requirements.
- 14.1.4 Prior to obtaining the temporary occupation permit from the relevant authority, the developer or owner shall obtain a coaxial readiness certification from an operator licensed to provide services over the broadband coaxial cable system.

14.2 Performance requirements for broadband coaxial cable system

14.2.1 Objective

The objective of the requirements included in this chapter is to ensure that the system performance limits are well optimised for the transmission of both upstream and downstream signals. Most of the technical requirements in this chapter are in line with and comply with published standards developed by the Society of Cable Telecommunications Engineers (SCTE), which is an accredited standards developing organisation of the American National Standards Institute (ANSI). However, given the specific operating conditions of the local broadband coaxial cable system, the requirements stated in this chapter shall apply, over and above the standards published by the SCTE. IDA reserves the right to revise the various requirements stated herein as technology develops and evolves over time.

14.2.2 General Requirements

All requirements refer to the performance limits that shall be obtained between the input to the head end or head ends and any system outlet when terminated in a resistance equal to the nominal load impedance of the system, unless otherwise specified. All system components shall also be suitable for bi-directional operation with the reverse path in the frequency range 5-42 MHz. Where system outlets are not used, the above applies at the subscriber's end of the subscriber's feeder.

14.2.3 Impedance

The nominal impedance of the system shall be 75Ω. It should be noted that this value applies to all coaxial feeder cables and system outlets and should be used as the reference impedance in level measurements.

14.2.4 Carrier levels at system outlets

(a) Minimum and maximum carrier levels

The minimum and maximum carrier levels at system outlets are shown in Table 14.2.4(a).

Table 14.2.4(a) Carrier signal levels at system outlets

Frequency Range and Service	Max. Level (dBμV)	Min. Level (dBμV)	Definitions
54-824 MHz television	80	60	These levels are expressed as the r.m.s. voltage of each carrier at the peak of the modulation envelope when measured at the system outlet across an external 75Ω termination or relative to 75Ω

14.3 Network topology

14.3.1 The network input port shall be designed for proper broadband coaxial cable system network operation with input levels and TV channel loading as follows:

- at 824MHz – Between 14 and 25 dBmV
- at 54MHz – Between 11 and 25 dBmV

14.3.2 Wiring facilities for broadband coaxial cable system cables

Suitable cable routes, such as trunking, conduits, risers, etc. as well as means of mechanical protection to the broadband coaxial cable system cables shall be provided for the wiring of a complete broadband coaxial cable system. The cable routes shall have as few bends as practicable.

14.3.3 Routing to residential units

- (a) The passive device (Tap/Tee) feeding the system outlets in each residential unit shall be connected to a dedicated subscriber feeder cable from the nearest distribution panel/box.
- (b) Subscriber feeder cables shall be installed in conduits throughout their entire length so that they cannot be accessed by unauthorised person(s). Where multiple feeder cables are bunched together, cable trunking, with adequate covers may be used in lieu of conduits.

- (c) No splice or termination between the passive device and the system outlet shall be made in the subscriber feeder cable, except within the residential unit.
- (d) All subscriber feeder cables shall be properly labelled and clearly marked at the distribution panel. The labels or markings shall designate the particular unit address to which each subscriber feeder cable is connected.

14.3.4 Distribution panels and boxes

- (a) The distribution panels/ boxes shall be lockable and securely mounted to the building wall. The distribution panels/boxes need not be lockable if they are securely mounted on the side of the telecommunication riser facing the door.
- (b) All connectors shall be located within the distribution panels/boxes to ensure effective shielding against RF ingress and egress.
- (c) The lockable distribution panels/boxes shall be able to accommodate the required number of in-line negative traps, accessories and amplifiers.

14.4 Cables

14.4.1 Coaxial cables shall be used for the installation of a broadband coaxial cable system. The cables shall meet or exceed the minimum requirements stated in this chapter.

14.4.2 Subscriber feeder (drop) cables (above ground) – RG6 coaxial cable

General requirements:

- (a) Characteristic impedance: $75\Omega \pm 2\Omega$;
- (b) Velocity of propagation: more than 85%;
- (c) Structural return loss: exceed 20dB (47-824 MHz);
- (d) The centre conductor shall be copper-clad steel, Beryllium copper alloy or hard drawn copper. It shall have a solid single core. It shall be compliant to the specifications of the SCTE for broadband coaxial cable systems;
- (e) The dielectric shall be gas expanded foam polyethylene;
- (f) The shielding shall consist of an aluminium-polypropylene-aluminium (or equivalent) laminated tape longitudinally wrapped with an overlap around the dielectric and shall be bonded to the dielectric with a layer of adhesive to provide 100% coverage and long-term reliability of shielding performance;

- (g) The outer jacket shall be polyvinyl chloride (PVC) for dry environment and polyethylene (PE) for damp environment;
- (h) The screening effectiveness shall be either:
 - (i) greater than 90dB at 200MHz when measured using the Dipole Antennae Procedure (see NCTA Recommended Practices for Measurements on Cable TV Systems, 2nd Edition, Part 1, Section J), or
 - (ii) greater than 80dB at 200MHz when measured using the Absorbing Clamp method (see pr EN 50083-2:1992);
- (i) The cables used shall be able to withstand long term operation in high humidity environments without deterioration; and
- (j) Suitable centre conductor with corrosion prevention should preferably be incorporated to reduce corrosion or oxidation of the centre conductor's copper surface.

14.4.3 Main cables (above ground)

General requirements:

- (a) All main cables shall be hard-line (solid outer conductor) cables;
- (b) The characteristic impedance shall be $75\Omega \pm 2\Omega$;
- (c) Velocity of propagation, more than 87%;
- (d) Structural return loss (measured with the cable under test terminated in its conjugate impedance) shall exceed 20dB at any frequency in the band 47-824 MHz;
- (e) The dielectric shall be gas expanded foam polyethylene or other dielectric of similar electrical properties. The cable with equivalent dielectric shall be in every respect no less effective than that with gas expanded foam polyethylene;
- (f) The dielectric shall be bonded to the outer conductor with an adhesive coating; and
- (g) For installations where cables must bend extensively or must bend at a radius of less than 10cm, only cables with outer jacket bonded to the outer conductor shall be used. Care must be taken not to bend the cables beyond their specified minimum bending radius. For such installations, .412 size cable with full bonding of jacket to outer conductor and outer conductor to dielectric is recommended.

14.4.4 Underground cables

Underground cable joints shall be avoided. Where it is necessary, suitable connectors shall be used and the joints shall be sealed with waterproofing compound.

The underground coaxial cables shall meet or exceed the requirements stated herein:

- (a) All underground main cables shall be hardline (solid outer conductor);
- (b) The characteristic impedance shall be $75\Omega \pm 2\Omega$;
- (c) Velocity of propagation, more than 87%;
- (d) Structural return loss (measured with the cable under test terminated in its conjugate impedance) shall exceed 30dB at any frequency in the band 47-824 MHz;
- (e) The dielectric shall be gas expanded foam polyethylene; and
- (f) The underground cables shall be waterproof and weather resistant.

14.5 Safety

14.5.1 Safety requirement

A cabled distribution system shall be so designed, constructed and installed as to present no danger, either in normal use or under fault conditions to subscribers, personnel working on or externally inspecting the system, or to any other person, providing particularly:

- (a) personal protection against electric shock;
- (b) personal protection against physical injury; and
- (c) protection against fire.

Note: The above does not apply to authorised personnel working on the apparatus, which may involve the exposure of live parts by the removal of protective covers.

14.5.2 Main-supplied apparatus

- (a) The devices used in a cabled distribution system shall meet the requirements of IEC 60065:2001 and the requirements of the Energy Market Authority ("EMA"). In addition, the specific requirements of the following sub-paragraphs (b) and (c) shall be met;
- (b) All mains connected apparatus shall employ a mains transformer complying with the insulation requirement given in IEC 60065:2001; and
- (c) Apparatus installed outdoors and operated from supply mains shall be contained in an appropriate drip-proof, splash-proof or water-tight enclosure so as to provide protection against moisture.

14.5.3 Safety bonding terminals

All amplifier housings, metallic mounting bays and racks shall be provided with an external safety bonding terminal complying with the relevant paragraphs of IEC 60065:2001.

Note: Taps, splitters etc may also be fitted with bonding terminals.

14.5.4 Connection to supply main

- (a) Connection of apparatus to the supply mains shall conform to the requirements of EMA; and
- (b) In the absence of any specific requirements by EMA, the following shall apply:
 - (i) The bonding terminal of the apparatus shall be connected to the earth conductor of the mains; and
 - (ii) If the design of the apparatus does not require it to be earthed, it shall then be clearly labelled and shall be isolated or enclosed with insulated materials.

Note: If different potentials build up between the earth conductor and the electrical earth of each apparatus, balancing current might flow, and critical parts might be overheated.

14.5.5 Feeders bonding

- (a) Metal enclosures, especially those containing live equipment, shall be bonded in accordance with the requirements of EMA. All units within the enclosure shall be bonded to the enclosure;
- (b) The outer conductors of coaxial cables entering or leaving a building shall be carefully bonded to the earth conductors of the mains;
- (c) The outer conductor and its connections between any system outlet and any other outlet or bonding shall be able to carry a current of 30A for 5 seconds;
- (d) Provisions shall be made to maintain bonding while units are changed or removed;
- (e) The conductor connected to the bonding terminal shall be mechanically stable, and have a cross-sectional area of at least 4mm²;
- (f) The maximum value of earth-loop impedance shall comply with the EMA's requirement concerning earth leakage protection; and
- (g) Every connection of an earthing lead to an earthing point shall be readily accessible and soundly made by the use of clamps or soldered joints.

14.5.6 Proximity to power distribution systems

- (a) The cabled network shall be adequately protected against inadvertent contact with, or induction from electrical power distribution systems; and
- (b) EMA's requirements concerning the proximity of the cabled network to electrical power distribution systems and installations of any high-voltage network shall be strictly observed in all respects and at all times.

14.5.7 Remote power supply (over the coaxial cable)

- (a) The nominal r.m.s. voltage between the inner conductor and the outer conductor of the coaxial cable shall not exceed 65V; and
- (b) The installation for the remote power supply including the coaxial cable shall comply with EMA's requirement.

14.5.8 Weather protection

All apparatus and cables exposed to weather, corrosive atmosphere or other adverse conditions shall be so constructed or protected as may be necessary to prevent danger from arising from such exposure.

14.6 Installation practices and procedures

14.6.1 Protection against moisture: the entire network shall be tightly sealed mechanically to prevent moisture from entering the electronic devices and coaxial cables.

14.6.2 Protection against corrosion shall be provided to metallic housing and devices. This is achieved by using any or all of the following methods:

- (a) Using corrosion-resistant material, such as stainless steel;
- (b) Galvanic protection;
- (c) Protective coating such as painting with rust-inhibiting paints; and
- (d) Other suitable corrosion prevention measures.

Where protective coatings are used, care should be taken to ensure electrical continuity.

14.6.3 Operating ambient conditions

All equipment shall be capable of continuous operation at ambient temperature up to 45°C and relative humidity of 100%.

14.7 Workmanship

14.7.1 All materials used shall be securely attached to permanent building walls or other structural members.

- 14.7.2 It is important to ensure that all F-type connectors are installed properly.
- 14.7.3 Adequate measures should be undertaken to ensure protection against moisture and corrosion (see paragraphs 14.6.1 and 14.6.2).
- 14.7.4 Whilst installing the heat-shrink tubing over the connectors, particular attention should be paid to the need to ensure that the tubing has been shrunk uniformly and that the adhesive is effective throughout.

14.8 Other technical details

- 14.8.1 Where amplifiers, passive devices (such as taps, splitters and system outlets), connectors and splices are provided by the developer or owner for the purposes of the broadband coaxial cable system, such amplifiers, passive devices, connectors and splices shall comply with the broadband coaxial cable system equipment specifications as set out in Appendix 4 of the Guidelines for Info-communication Facilities in Buildings.

CHAPTER 15 REQUIREMENTS FOR INSTALLATION OF OPTICAL FIBRE CABLES IN RESIDENTIAL DEVELOPMENTS

15.1 General

15.1.1 This chapter sets out the requirements for the construction, cabling, installation, safety and performance of an optical fibre cable from the telecommunication riser or gate pillar (or meter compartment) to each residential unit within a residential development as specified in Chapters 4 to 7.

15.2 Installation of optical fibre cable from telecommunication riser or gate pillar (or meter compartment) to each residential unit

15.2.1 A minimum of 1 2-core optical fibre cable shall be installed in the conduit or underground pipe designated for non-coaxial cable system, as specified in the relevant chapters of this Code.

15.2.2 The 2-core optical fibre cable shall be terminated, with an additional 2m length as “slack”, at each end into:

- (a) a fibre interface point which is located in the telecommunication riser or gate pillar (or meter compartment); and
- (b) a fibre termination point which is located in the residential unit.

The fibre interface point and fibre termination point shall each be a set of 2 SC/APC connectors.

15.2.3 Where the fibre interface point is located in the telecommunication riser, the fibre interface point shall be located on the same floor as the residential unit.

15.2.4 The fibre interface point should be clearly labelled, indicating the corresponding residential unit where the 2-core optical fibre cable is installed.

15.3 Optical fibre cable specifications for installation in conduits

15.3.1 The optical fibre cable used shall:

- (a) Comply with the G.657 Category A specifications in the ITU-T Recommendations;
- (b) Comprise an outer sheath of fire retardant polyethylene or Low Smoke Free of Halogen (LSFH) material;
- (c) Have a central strength member that is made of Aramid Yarn (Kevlar Yarn) or its equivalent; and
- (d) Be able to withstand a maximum tensile load of at least 500N.

15.4 Optical fibre cable specifications for installation in underground pipe

- 15.4.1 The optical fibre cable used shall:
- (a) Comply with the specifications in sub-category G.652.D in the ITU-T Recommendations;
 - (b) Have a loose tube with filled jelly compound and polyethylene sheath;
 - (c) Have a central strength member that is made of Aramid Yarn (Kevlar Yarn) or its equivalent; and
 - (d) Use water blocking tape to enhance prevention of water armouring.

15.5 Fibre interface point

- 15.5.1 The fibre interface point shall be securely mounted:
- (a) at the side of the telecommunication riser facing the door; and
 - (b) in closer proximity to the cables and associated cabling facilities for non-coaxial cables.
- 15.5.2 Where there is no telecommunication riser, the fibre interface point shall be securely mounted inside the gate pillar (or meter compartment) at a height which is at least 1m.
- 15.5.3 The fibre interface point shall have 2 SC/APC connectors.

15.6 Fibre termination point

- 15.6.1 The fibre termination point shall have 2 SC/APC connectors.
- 15.6.2 The fibre termination point shall:
- (a) be securely mounted adjacent to the RJ45 patch panel (which may be located in the utility room or closet) and 13A switch socket outlet; and
 - (b) have a clear space of 50mm from the SC/APC connectors to allow the connection of patch cords.

15.7 Safety requirements

- 15.7.1 The optical fibre cable from the telecommunication riser or gate pillar (or meter compartment) to each residential unit shall be designed, constructed and installed to present no hazard or danger, be it for normal usage or under fault conditions, to subscribers, personnel working on or inspecting the system, or to any other person.
- 15.7.2 The following precautions shall be taken into consideration while handling or working with any optical fibre cable:

- (a) Keep all food and beverages out of the work area as ingesting optical fibre particles may cause internal haemorrhage;
- (b) Work on a black work surface for better visibility of optical fibre scraps;
- (c) Wear disposable aprons to prevent optical fibre particles from coming into contact with clothing;
- (d) Always wear safety glasses with side shields and protective gloves;
- (e) Never look directly into the end of fibre optic cables unless necessary. If there is a need to look into the end of the fibre optical fibre, confirm that there is no light source at the other end. Use a fibre optic power meter to make certain the fibre optical cable is dark. When using an optical tracer or continuity checker, look at the fibre from an angle at least 6 inches away from the eyes to determine if visible light is present;
- (f) All work areas must be well ventilated;
- (g) Contact lens wearers must not handle their lenses until they have thoroughly washed their hands;
- (h) Do not touch the eyes with hands while working with optical fibre cables until the hands have been thoroughly washed;
- (i) All cut optical fibre pieces must be placed in a properly marked container for disposal;
- (j) All work areas must be thoroughly cleaned upon the completion of work; and
- (k) No smoking while working with optical fibre cables.

15.8 Testing criteria for the optical fibre cable from the telecommunication riser or gate pillar (or meter compartment) to each residential unit

15.8.1 To ensure that the optical fibre cable is in good working condition upon completion of installation works, both of the following methods of testing must be carried out:

- (a) Continuity testing – This involves checking that the optical fibre cable is not physically broken at any point, and that the optical fibre cable does indeed go from one location to the correct destination using a powerful visible red laser; and
- (b) Scanning at the fibre interface/termination point with an Optical Time Domain Reflectometer (OTDR) – An OTDR is capable of measuring the fibre lengths, losses, connector losses, splice losses and fibre defects, and works by sending a pulse of light into the fibre and measuring how much light is reflected back and detected at the OTDR. It will produce a line or graph on a screen and by measuring how much light is reflected, the OTDR can determine the loss associated with each of these

anomalies. The optical fibre cable will be treated as being in good working condition if the losses measured between the fibre interface point at the telecommunication riser or the gate pillar (or meter compartment) and the fibre termination point at the residential unit using the OTDR are less than 0.6dB.

15.9 Fibre Readiness Certification

- 15.9.1 Prior to obtaining temporary occupation permit from the relevant authority, the developer or owner shall obtain fibre readiness certification from an operator licensed to provide passive optical fibre connectivity service.
- 15.9.2 There should not be any significant wiring change after the optical fibre cable and its associated fibre interface and termination points have been certified “fibre-ready”.

CHAPTER 16 USE OF SPACE AND FACILITIES BY LICENSEES**16.1 Application of this chapter**

- 16.1.1 This chapter specifies the requirements to be observed by every licensee that deploys its installation, plant or system within the space and facilities of any development provided pursuant to this Code or any previous codes.
- 16.1.2 For the purposes of this chapter, where a licensee connects its pipes to the lead-in pipes of a development, such connection shall be regarded as a deployment of plant by such licensee.

16.2 Eligibility to use

- 16.2.1 Only licensees who –
- (a) provide telecommunication services via fixed-line method or fixed-wireless method may deploy their installation, plant or system in the relevant space and facilities (save for the mobile deployment space) of a development; and
 - (b) provide public cellular mobile telecommunication services may deploy their installation, plant or system in the relevant space and facilities (save for the main distribution frame room and the telecommunication equipment room) of a development.

16.3 Access to relevant space and facilities

- 16.3.1 Every licensee who wishes to deploy its installation, plant or system in the relevant space and facilities of any development to provide telecommunication services to that development shall give notice to the developer or owner of that development, stating:
- (a) as fully and accurately as possible the nature and extent of the acts intended to be done; and
 - (b) a reasonable timeframe (which shall in any case be no less than 14 days) for the developer or owner to raise its objection (if any) to the licensee's intended use of the space and facilities.
- 16.3.2 Every licensee who wishes to access the relevant space and facilities of any development for the purpose of inspecting, maintaining, repairing or upgrading any installation, plant or system which it has deployed in such space and facilities shall give reasonable notice to the developer or owner of that development to obtain grant of access.
- 16.3.3 Every licensee who accesses the relevant space and facilities to deploy installation, plant or system used for telecommunication purposes, shall take such action as may be necessary to render such installation, plant or system safe and efficient.

16.4 Rules of usage

16.4.1 Every licensee who deploys its installation, plant or system in the relevant space and facilities of any development shall –

- (a) ensure that it deploys its installation, plant or system in the most efficient manner possible;
- (b) only deploy such installation, plant or system as is reasonably necessary to meet the demand for its services and where the licensee is a public telecommunication licensee, to also meet its basic service obligations;
- (c) not deploy its installation, plant or system in a manner which unreasonably prevents any other licensee who wishes to deploy its installation, plant or system within the same space and facilities from doing so;
- (d) co-operate in good faith with any other licensee who wishes to deploy its installation, plant or system within the same space and facilities to enable such licensee to carry out its deployment in an expedient manner;
- (e) not make any structural alteration to the relevant space and facilities without the approval of the developer or owner of that development;
- (f) take due care to maintain the cleanliness and condition of the relevant space and facilities in which it deploys its installation, plant or system, and those parts of the land which it accesses in connection with such deployment;
- (g) where it causes any damage to the relevant space and facilities in which it deploys its installation, plant or system, or to those parts of the land which it accesses in connection with such deployment, inform the developer or owner of that development and make good the damage caused;
- (h) when carrying out any activities in connection with its deployment of installation, plant or system in the relevant space and facilities, take reasonable steps to minimise the disturbance and inconvenience caused to the occupants of the building and comply with all requirements imposed by the relevant authorities including any limits on noise levels and safety;
- (i) subject to paragraphs 16.4.3 to 16.4.6, pay for all utility charges incurred for the operation of the installation, plant or system deployed in the relevant space and facilities unless otherwise agreed with the developer or owner of that development;
- (j) where it is necessary to drill through any concrete floor or wall of buildings for the laying of its installation, plant or system, consult and obtain the written approval of the developer or owner of that

development, and be responsible for any such drilling works at its own cost;

- (k) where it is necessary for the laying of its installation, plant or system, be responsible for the removal and replacement of the fire resistant material used to seal the inter-floor openings for the telecommunication risers, at its own expense; and
- (l) where it ceases to provide any service to that building, remove, within a reasonable timeframe, any installation, plant or system deployed in the relevant space and facilities which is no longer required.

16.4.2 For the purposes of paragraph 16.4.1, all references to the act of deployment of any installation, plant or system shall include the act of inspecting, maintaining or repairing such installation, plant or system.

16.4.3 Where the developer or owner has served a notice requiring any licensee to bear utility charges for the operation of any installation, plant or system deployed by the licensee in the relevant space and facilities, the licensee shall bear the utility charges on a prospective basis commencing no earlier than a period of one (1) month from the date of service of such notice.

16.4.4 Where such notice as specified in paragraph 16.4.3 is served on the licensee, the developer or owner and the licensee shall reach an agreement on the basis upon which to compute the utility charges to be borne by the licensee. Where the developer or owner and the licensee are unable to agree on such basis, the utility charges to be borne by the licensee shall be based on the estimated power consumption of the licensee's installation, plant or system.

16.4.5 Notwithstanding paragraph 16.4.4, where it is physically feasible, the licensee may, at its own cost, install the necessary electrical installations (including cables, a separate utility meter and any other accessories) to enable the utility charges to be computed on an "as incurred" basis and paid directly to the utility provider.

16.4.6 For the avoidance of doubt, the developer or owner shall not require the licensee to bear any utility charges incurred prior to the commencement date referred to in paragraph 16.4.3.

16.5 Sealing of underground pipes leading into an air-conditioned or unventilated main distribution frame room or telecommunication equipment room

16.5.1 Where a licensee has, prior to the Effective Date, taken over from any developer or owner any underground pipes leading into –

- (a) any main distribution frame room or telecommunication equipment room that is air-conditioned; or
- (b) any main distribution frame room or telecommunication equipment room that is not air-conditioned and which has no free-flowing ventilation (such as a room with no louvres or exhaust fans or their equivalent)

(collectively referred to in this paragraph 16.5 as an “Enclosed Room”), the licensee shall ensure that it seals the relevant underground pipe at its point of entry into such Enclosed Room with the Appropriate Sealing Material (as defined in paragraph 16.5.3) within 2 years from the Effective Date.

- 16.5.2 From the Effective Date, every licensee that deploys its telecommunication cables into any underground pipe leading into any Enclosed Room shall ensure that it seals the relevant underground pipe at its point of entry into such room with the Appropriate Sealing Material (as defined in paragraph 16.5.3). Where the underground pipes are already sealed prior to the licensee deploying its telecommunication cables, the licensee shall be responsible for removing the existing seal and re-sealing the pipes upon completion of its cable installation work.
- 16.5.3 For the purposes of this paragraph 16.5, “Appropriate Sealing Material” means a material that is able to prevent foreign gaseous matter (which may be toxic or flammable) from passing through the underground pipes into the Enclosed Room and which shall be durable, easily removable to facilitate installation of cables, and not cause damage to the underground pipes or any telecommunication cables that may be installed therein.

16.6 Deployment of installation, plant or system

- 16.6.1 Where a licensee (the “Existing Licensee”) has deployed its installation, plant or system in a manner which does not efficiently optimise the use of the relevant space and facilities (save for mobile deployment space), the Existing Licensee shall co-operate in good faith with any other licensee (the “Requesting Licensee”) who wishes to deploy its installation, plant or system within the same space and facilities to:
- (a) rearrange, remove or alter, at the Existing Licensee’s own expense, such installation, plant or system or any part thereof; and
 - (b) perform any such rearrangement, removal or alteration within a reasonable timeframe to facilitate deployment by the Requesting Licensee.
- 16.6.2 In the event that the licensees are unable to reach agreement on the rearrangement, removal or alteration that should be effected, they may refer the matter to IDA for a decision which shall be binding on the licensees.
- 16.6.3 Subject to paragraphs 16.6.4 and 16.6.5, each mobile telecommunication licensee may deploy its installation, plant or system for the provision of public cellular mobile telecommunication services in the mobile deployment space of a development (without MRT and road tunnels).
- 16.6.4 Where a mobile telecommunication licensee (the “Earlier MTL”) has occupied more than the allocated space (“Allocated Mobile Deployment Space”) for each mobile telecommunication licensee in accordance with the dimensions specified in Table 16.6.4 (based on the deployment space provided by the developer or owner as required under the relevant chapters), and if another mobile telecommunication licensee (the “Later MTL”) wishes to deploy its

installation, plant or system in the mobile deployment space for the provision of public cellular mobile telecommunication services, the Earlier MTL shall:

- (a) remove, within a reasonable timeframe, the Earlier MTL's deployed installation, plant or system to the extent that the Later MTL is able to deploy the Later MTL's installation, plant or system in the Later MTL's Allocated Mobile Deployment Space; and
- (b) bear all costs in connection with any such removal.

Table 16.6.4 Allocated Mobile Deployment Space for each mobile telecommunication licensee

Mobile deployment space (m ²)	Allocated Mobile Deployment Space (m ²)
18 or 24 (as the case may be)	6 or 8 (as the case may be)
36	12
54	18
72	24

- 16.6.5 All mobile telecommunication licensees who have deployed their installation, plant or system in the mobile deployment space shall share among themselves on an equal basis (unless otherwise agreed), any remaining mobile deployment space which is in excess of their total Allocated Mobile Deployment Space.
- 16.6.6 For developments with 1 or more MRT or road tunnel(s), each mobile telecommunication licensee shall co-operate in good faith to reach agreement with all the other mobile telecommunication licensees as to the allocation of the mobile deployment space that is provided by the developer or owner under chapter 10.

16.7 Connections to lead-in pipes

- 16.7.1 Every licensee that connects its pipes to the lead-in pipes of a development shall only make such number of connections as are necessary to meet the demand for its services.
- 16.7.2 Where a licensee has connected its pipes to the lead-in pipes of any development but is not using any of its pipes ("Unused Pipe") or is using less than 50% of the space in any of its pipes ("Partially Used Pipe"), and the Requesting Licensee requires the use of the licensee's Unused Pipe or the space in the licensee's Partially Used Pipe, that licensee shall allow the Requesting Licensee to use the licensee's Unused Pipe or the space in the licensee's Partially Used Pipe, including the use of the associated lead-in manholes, at cost-based prices.
- 16.7.3 Every licensee that connects its pipes to the lead-in pipes of a development shall –

- (a) ensure that the pipes and the associated lead-in manholes which it connects to the lead-in pipes are grouped together and not placed in a manner which obstructs any other licensee from connecting its own pipes to the lead-in pipes; and
- (b) connect its pipes to the lead-in pipes in a left-to-right or right-to-left method (depending on where the previous connection has been made) or in a bottom-up manner as illustrated in Figure 16.7.3.

Figure 16.7.3 Method in which licensees are to connect to lead-in pipes

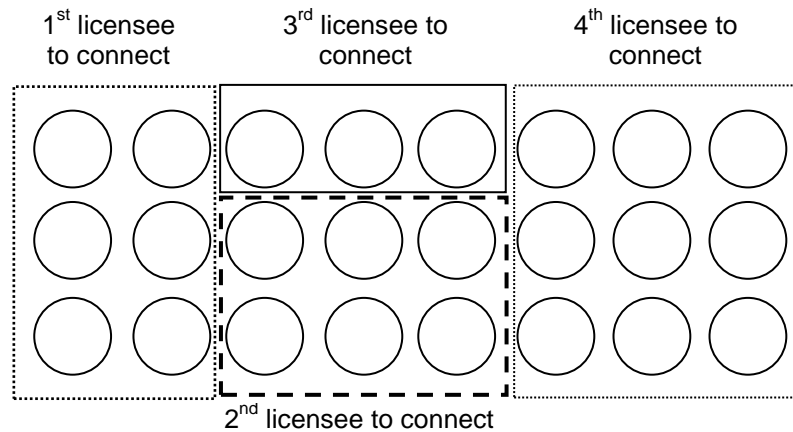

16.7.4 IDA may require any licensee who fails to comply with paragraph 16.7.3 to remove or re-position its connections to the lead-in pipes or to remove or re-position its manholes at its own expense.

16.7.5 Every licensee who deploys multiple telecommunication cables to the same development shall, where practicable, install sub-ducts or their equivalent in the lead-in pipes such that each lead-in pipe is able to accommodate multiple telecommunication cables.

16.8 Concurrent deployment or connections by two or more licensees

16.8.1 Where two or more licensees concurrently seek to deploy their installation, plant or systems in the relevant space and facilities or concurrently seek to connect their pipes to the lead-in pipes of any development, and such relevant space and facilities are insufficient to accommodate all the installation, or plant or systems sought to be deployed or the lead-in pipes are insufficient to accommodate all the connections sought to be made, the licensees shall first attempt to reach a voluntary sharing arrangement in good faith.

16.8.2 In the event that the licensees are unable to reach a sharing arrangement, they may refer the matter to IDA for a decision which shall be binding on the licensees.

16.8.3 In determining the sharing arrangement, IDA will generally grant priority as follows –

- (a) public telecommunication licensees who require use of the relevant space and facilities to provide services to the development in accordance with their basic service obligations shall have first priority;
- (b) telecommunication system licensees who require use of the relevant space and facilities to provide services to the development shall have second priority; and
- (c) telecommunication system licensees who require use of the relevant space and facilities for any other purpose shall have last priority.

16.9 Co-operation to resolve interference

- 16.9.1 Where any installation, plant or system deployed by a licensee in the relevant space and facilities of a development causes interference to the operation of installation, plant or system deployed by any other licensee in the same space and facilities, such licensees shall co-operate in good faith to resolve the interference to ensure minimal disruption to service provisioning.

16.10 Contravention by licensee

- 16.10.1 Where any licensee contravenes any requirement in this chapter, IDA may require such licensee to rearrange, remove, alter or disconnect any of the installation, plant or system which it has deployed in the relevant space and facilities of any development at its own expense.

16.11 Provision of additional space or facilities

- 16.11.1 Where a licensee requires additional facilities (beyond the minimum requirements as set out in this Code) for the purposes of provision of its services to the relevant development, the licensee shall consult and obtain the approval of the developer or owner for the licensee to provide the same and shall do so at the licensee's own cost.
- 16.11.2 Where a licensee requires additional space (beyond the minimum requirements as set out in this Code) for the purposes of provision of its services to the relevant development, the licensee shall consult and obtain the approval of the developer or owner for the developer or owner to provide the same at the licensee's cost.

CHAPTER 17 USE OF SPACE AND FACILITIES WITHIN A DEVELOPMENT FOR THE PROVISION OF TELECOMMUNICATION SERVICES TO PROPERTIES OUTSIDE OF THE DEVELOPMENT

17.1 Application of this chapter

17.1.1 This chapter sets out –

- (a) the procedures to be observed by a licensee that intends to use the space and facilities provided within a development to serve properties outside of the development;
- (b) the procedures to be observed by a developer or owner who is notified by a licensee of such intended use of the space and facilities; and
- (c) the principles that IDA may adopt in resolving disputes between the parties where IDA determines that such use of the space and facilities is reasonable.

17.2 Overview

17.2.1 The space and facilities provided by a developer or owner of a development pursuant to this Code or any previous codes (hereinafter referred to as “**COPIF space and facilities**”) are primarily intended for licensees to deploy installation, plant or systems to serve the telecommunication needs of the development. Accordingly, insofar as the use of COPIF space and facilities is concerned, priority should be accorded to the needs of the development at all times.

17.2.2 Nevertheless, there may be situations where it would be reasonable for a licensee that is providing telecommunication services to a development and using that development’s COPIF space and facilities to also use such COPIF space and facilities to provide telecommunication services to properties located outside of the development (hereinafter referred to as “**external properties**”).

17.2.3 Such situations are specifically contemplated in Section 21(2) of the Telecommunications Act (Cap. 323). In these cases, the licensee is required to notify the developer or owner of its intention to use the COPIF space and facilities to serve the external properties. If the developer or owner objects to such intended use, the licensee may refer the matter to IDA for determination. Where IDA is satisfied that the licensee’s use of the COPIF space and facilities to serve the external properties would be reasonable, IDA may issue directions to the parties to give effect to the same on such terms and conditions as IDA may impose.

17.3 Procedures to be observed in relation to the use of COPIF space and facilities to serve external properties

17.3.1 Where a licensee intends to use the COPIF space and facilities in a development to serve any external properties, the licensee shall notify the developer or owner of such intention. The notice shall minimally include the following –

- (a) clear indication of the licensee's intention to use the COPIF space and facilities in the development to serve external properties;
- (b) description of the installation, plant or system that the licensee will be deploying in the COPIF space and facilities to serve the external properties;
- (c) proposed dates of the deployment of the installation, plant or system and the duration of the deployment period;
- (d) material implications regarding the deployment and use of the installation, plant or system to serve the external properties, including the likely frequency of access for the purpose of undertaking any activities in connection with such installation, plant and systems; and
- (e) a reasonable timeframe (which shall in any case be no less than 14 days) for the developer or owner to raise its objection (if any) to the licensee's intended use of the COPIF space and facilities to serve the external properties.

17.3.2 Where the developer or owner objects to the licensee's intended use of the COPIF space and facilities to serve the external properties, the developer or owner shall raise its objection to the licensee within the stipulated timeframe in the notification and state the reasons for its objection.

17.3.3 The licensee and the developer or owner shall co-operate in good faith and seek to arrive at a mutually acceptable agreement on the use of the COPIF space and facilities to serve the external properties.

17.3.4 Where the developer or owner objects to the licensee's use of the COPIF space and facilities to serve the external properties, the licensee may refer the matter to IDA for determination.

17.3.5 IDA will provide an opportunity for the parties to make representations to IDA in accordance with such process as IDA may specify.

17.3.6 IDA's determination of –

- (a) whether it would be reasonable for a licensee to use the COPIF space and facilities to serve the external properties; and/or

- (b) the terms and conditions to be imposed on the parties where IDA assesses that such use should be allowed,

will be undertaken by IDA on a case-by-case basis having regard to all relevant facts, including factors such as the availability of the COPIF space and facilities for such intended use, as well as any safety and security considerations which IDA considers to be relevant.

17.3.7 Where IDA determines that the licensee's intended use of the COPIF space and facilities is reasonable, IDA may issue directions to –

- (a) require the developer or owner to allow the licensee to use the COPIF space and facilities to serve the external properties; and
- (b) require the licensee to install and operate any installation, plant or systems within the COPIF space and facilities to serve the external properties,

in such manner and on such terms and conditions as IDA may specify in the directions.

17.3.8 Without prejudice to paragraph 17.3.6 above, where IDA considers that it would be reasonable to allow a licensee to use the COPIF space and facilities to serve any external properties, IDA may (but is not bound to) adopt the principles set out in paragraph 17.4 below when specifying the terms and conditions to be complied with by the licensee and the developer or owner in relation to such use of the COPIF space and facilities. Parties are therefore encouraged to refer to the said principles with a view to arriving at a mutually acceptable agreement without the need for IDA's intervention.

17.4 Guiding principles on the use of COPIF space and facilities to serve external properties

17.4.1 In all instances, priority in the use of the COPIF space and facilities within a development must be accorded to the immediate and foreseeable needs of the development before such space and facilities may be used to serve external properties.

17.4.2 In the event that the installation, plant or system deployed by a licensee to serve external properties impedes or causes obstruction to any future deployment of installation, plant or system by other licensees to serve the needs of the development, the licensee shall –

- (a) remove its installation, plant or system at its own costs and reinstate as far as reasonably practicable to their original condition the COPIF space and facilities which were used; or
- (b) pay for the costs of any additional space and facilities required to accommodate such future deployment needs where it is feasible for such additional space and facilities to be provided.

- 17.4.3 The licensee shall comply with any reasonable measures that the developer or owner may impose to safeguard the safety and security of the development, in connection with the licensee's activities relating to the installation, plant or system that are deployed to serve the external properties.
- 17.4.4 The licensee shall bear all risks in relation to the installation, plant or system that are deployed to serve the external properties. In this regard, the licensee (and all persons claiming under it) shall waive the right to make any claims against the developer or owner and any occupants of the development for any loss or damage caused to such installation, plant or system howsoever arising save where such loss or damage is wilfully caused by such persons.
- 17.4.5 The licensee shall –
- (a) fully compensate the developer or owner and the occupants of the development for any loss or damage caused to the development or its occupants; and
 - (b) fully indemnify the developer or owner and the occupants of the development against any claims whatsoever made against them by any person,
- arising out of or in connection with the licensee's activities relating to the installation, plant or system that are deployed to serve the external properties.
- 17.4.6 The licensee shall comply with the rules of usage set out in Chapter 16, which shall equally apply to the licensee's use of the COPIF space and facilities to serve external properties.
- 17.4.7 Where it is reasonably necessary for the installation, plant or system that are deployed by the licensee to serve the external properties to be altered, removed, relocated or diverted (for example, where the development is being redeveloped), the licensee shall bear the costs of all such alteration, removal, relocation or diversion works.
- 17.4.8 Save where otherwise provided in this Code, the developer or owner shall not impose any charges, fees or rent for the licensee's use of the COPIF space and facilities to serve any external properties.
- 17.4.9 Where the developer or owner is required to incur any additional costs in granting access to the licensee to carry out any activities relating to the installation, plant or system that are deployed to serve the external properties, the developer or owner may recover these costs from the licensee subject to the developer or owner demonstrating that it is reasonable for such costs to be incurred.
- 17.4.10 In addition to allowing the licensee to deploy its installation, plant or system to serve the external properties, the developer or owner shall co-operate in good faith with the licensee to grant the licensee such continuing access to the development as the licensee may from time to time require to carry out any activities relating to such installation, plant or system, including the activation and deactivation of services, inspection, maintenance and repair.