

SCHEDULE 4B
SUBMARINE CABLE CONNECTION SERVICE

SCHEDULE 4B

SUBMARINE CABLE CONNECTION SERVICE

CONTENTS

1. SCOPE	1
2. CATEGORIES OF CABLE SYSTEMS	3
3. LINK AND CAPACITY ACTIVATION REQUEST	3
4. DELIVERY	9
5. DEACTIVATION	9
6. STANDARD TERMS AND CONDITIONS	11
7. ACCESS AND APPROVALS REQUIRED	11
8. OPERATIONS AND MAINTENANCE	12
9. TERM	15
10. SUSPENSION	15
11. TERMINATION	16
ANNEX 4B.1: CONNECTION SERVICE DIAGRAM FOR GROUP A SUBMARINE CABLE SYSTEMS	
ANNEX 4B.2: CONNECTION SERVICE DIAGRAM FOR GROUP B SUBMARINE CABLE SYSTEMS	
ANNEX 4B.3: LINK-CAPACITY ACTIVATION REQUEST	
ANNEX 4B.4: LINK-CAPACITY DEACTIVATION REQUEST	
ANNEX 4B.5: CABLE SYSTEMS	
ANNEX 4B.6: SERVICE LEVEL GUARANTEES	

SCHEDULE 4B

SUBMARINE CABLE CONNECTION SERVICE

1. SCOPE

1.1 This Schedule sets out the terms and conditions under which SingTel will provide the Requesting Licensee with the Connection Service and on which the Requesting Licensee may access or use the Connection Service.

1.2 The Connection Service is a service provided by SingTel to the Requesting Licensee for implementing, establishing and maintaining a connection between:

(a) the Requesting Licensee's Co-Location Equipment located at the Co-Location Space at the Submarine Cable Landing Station, or such other location as contemplated in the process set out in clauses 1.2 to 1.6 of Schedule 8; and

(b) a Cable System,

for the sole purpose of accessing cable capacity on the Cable System in accordance with clause 1.3, and is made up of a link activation and/or a capacity activation.

1.3 SingTel shall provide the Connection Service to the Requesting Licensee solely for the purposes of enabling the Requesting Licensee to:

(a) access its own cable capacity on any Cable System at the relevant Submarine Cable Landing Station; and/or

(b) access the cable capacity owned by any Third Party, on any Cable System at the relevant Submarine Cable Landing Station for the purpose of:

(i) providing a backhaul service to that Third Party who is duly licensed by the Authority; and/or

(ii) enabling that Third Party to transit traffic between any Cable System at the relevant Submarine Cable Landing Station being connected under this Schedule 4B (**A-end Cable System**) and another cable system (**B-end cable system**). For the avoidance of doubt, if SingTel is the landing party of the B-end cable system, the Requesting Licensee may request the Connection Service from SingTel in respect of that B-end Cable System pursuant to

this Schedule 4B. For the avoidance of doubt, a Requesting Licensee is not precluded from obtaining Connection Service to access multiple Cable Systems under this clause 1.3.

- 1.4 The provision of Co-Location Space and physical access thereto at a Submarine Cable Landing Station must be acquired by a Requesting Licensee in accordance with Schedule 8D or using the process contemplated in clauses 1.2 to 1.6 of Schedule 8.
- 1.5 This Schedule only applies to Requesting Licensees who are FBOs.
- 1.6 The timeframes in this Schedule relating to provisioning and fault rectification by SingTel are subject to variation due to delays caused by events outside SingTel's reasonable control, in which case such failure to fulfil the relevant Service Level Guarantee shall not constitute a breach of this Schedule or this RIO Agreement and clause 1.7 shall not apply, provided that SingTel notifies the Requesting Licensee as soon as practicable upon the occurrence of such event, stating the cause of the delay and specifying a new date for the completion of the relevant Connection Service work equal to the period of such delays.
- 1.7 SingTel will provide the Service Level Guarantees in respect of the Connection Service as set out in Annex 4B.6. If SingTel fails to meet any Service Level Guarantees applicable to this Schedule and the failure to meet the Service Level Guarantees is solely caused by SingTel, SingTel will provide a remedy to the Requesting Licensee in accordance with:
 - (a) sections 1 and 2 of Annex 4B.6 and any terms and conditions contained therein in respect of Link Capacity Activation Request and Provisioning timeframes;
 - (b) section 3 of Annex 4B.6 and any terms and conditions contained therein in respect of fault rectification timeframes; and
 - (c) section 4 of Annex 4B.6 in respect of claims made under Annex 4B.6.
- 1.8 The Requesting Licensee acknowledges that the relevant remedy provided under clause 1.7 is a genuine pre-estimate of the Requesting Licensee's loss and will be the sole and exclusive remedy available to the Requesting Licensee to meet the relevant timeframes for Connection Service and shall be SingTel's sole and exclusive liability to the Requesting Licensee for such failure.

2. CATEGORIES OF CABLE SYSTEMS

2.1 Existing Cable Systems

- (a) The terms and conditions of the Connection Service vary according to the Cable System. For this purpose, Cable Systems are divided into Group A Cable Systems and Group B Cable Systems, as described in Annex 4B.5.
- (b) The method of access to Group A Cable Systems is shown in Annex 4B.1.
- (c) The method of access to Group B Cable Systems is via a Cross Connect System, as shown in Annex 4B.2.

2.2 New Cable Systems

- (a) Where a new Cable System, which is not specified in clause 2.1 and Annex 4B.5 (**New Cable System**), lands at any Submarine Cable Landing Station, SingTel shall submit to the Authority for approval any necessary amendments to the RIO (including but not limited to Schedules 4B and 8D) to incorporate the New Cable System into the RIO, within such reasonable period prior to the Ready for Service Date of the New Cable System so as to enable the Requesting Licensee to obtain Connection Services to access the New Cable System by the Ready for Service Date. Upon approval by the Authority, SingTel shall amend the RIO and this RIO Agreement accordingly.
- (b) The Requesting Licensee may request the Connection Service in respect of the New Cable System where the Requesting Licensee has obtained or is in the process of obtaining Co-Location Space under Schedule 8D or Co-location Space contemplated in clauses 1.2 to 1.6 of Schedule 8 and where the New Cable System lands at the Submarine Cable Landing Station at which the Co-location Space is obtained.

3. LINK AND CAPACITY ACTIVATION REQUEST

- 3.1 SingTel shall offer to provide the Connection Service to a Requesting Licensee on terms and conditions that are no less favourable than the terms and conditions on which it provides comparable services to itself or its affiliates.
- 3.2 The Requesting Licensee shall submit its link activation and/or capacity activation requests in the form of a Link Capacity Activation Request Form (**LCAR Form**) provided in Annex 4B.3, with the relevant boxes checked. The

LCAR Form must be provided to SingTel no less than ten (10) Business Days prior to the requested date of activation of the:

- (a) link (**Link Activation Date**);
- (b) capacity (**Capacity Activation Date**); or
- (c) both link and capacity (**Link Capacity Activation Date**).

For the avoidance of doubt, in respect of Group B Cable Systems, a Requesting Licensee is permitted to request capacity activation together with activation of its associated link within one single request.

3.3 SingTel shall process the LCAR Form and advise the Requesting Licensee, within one (1) Business Day of its receipt or any other period as may be agreed between the parties, with one of the following responses:

- (a) that the LCAR Form has been accepted and that SingTel is able to activate the requested link and/or capacity by the Link Activation Date, Capacity Activation Date, or Link and Capacity Activation Date (as relevant);
- (b) that SingTel is able to activate the requested link and/or capacity, as the case may be, but will not be able to do so by the date specified in the LCAR Form as procurement is required, in which case SingTel shall advise the Requesting Licensee within a further four (4) Business Days of the relevant Link Activation Date, Capacity Activation Date, or Link and Capacity Activation Date (as relevant); or
- (c) that the LCAR form is rejected for a reason specified in clause 3.7.

3.4 SingTel shall process and respond to all requests under this Schedule 4B on a 'first come, first served' basis in the timeframe specified in this clause 3 in respect of the relevant LCAR Form. SingTel shall process a maximum of five (5) LCAR Forms per day from all Requesting Licensees under this Schedule 4B (whether those requests are made under this clause 3 or clause 5). Any subsequent requests received by SingTel in excess of this maximum amount shall overflow to the next Business Day, in which case SingTel shall, within one (1) Business Day of the Request Date, advise the Requesting Licensee of the queue number of the relevant request. For the purposes of this Schedule 4B, the Request Date shall be determined as follows:

- (a) if the LCAR Form is received before 12:00 noon on a Business Day, the Request Date is the Business Day the LCAR Form is received; or
 - (b) if the LCAR Form is received at or after 12:00 noon on a Business Day, the Request Date is the next Business Day after the Business Day on which the LCAR Form is received.
- 3.5 Where a request for link activation and/or capacity activation is to access the cable capacity of any Third Party on a Cable System, as contemplated by clause 1.3(b):
- (a) SingTel will not be obliged to activate the capacity unless and until the Requesting Licensee provides to SingTel a copy of a letter of authorisation issued by the Third Party authorising the Requesting Licensee to access the relevant Third Party's capacity;
 - (b) the Requesting Licensee must inform SingTel in writing within forty eight (48) hours if such authorisation is varied or revoked; and
 - (c) if the Requesting Licensee's authorisation is revoked, SingTel's obligation to supply the Connection Service will cease immediately in accordance with clause 11.1.
- 3.6 The requirements in clause 3.5 are in addition to and are not substitutes for the requirement for the Requesting Licensee to submit the LCAR Form in respect of the Connection Service sought. For the avoidance of doubt, the Requesting Licensee shall submit separate LCAR Forms for each of the A-end Cable System and, if SingTel is the landing party in respect of the B-end cable system, the B-end cable system.
- 3.7 SingTel may reject the LCAR Form (and shall provide reasons to the Requesting Licensee explaining the basis for such rejection) if:
- (a) the LCAR Form is in respect of a Cable System other than as specified in clause 2.1;
 - (b) the LCAR Form is not in the prescribed form specified in this Schedule 4B;
 - (c) where the Connection Service is sought in relation to accessing the cable capacity of any Third Party, the LCAR Form is not accompanied by the Third Party's letter of authorisation specified in clause 3.5(a);

- (d) the LCAR Form does not contain all the required information;
- (e) prior to the RFS Date, the Requesting Licensee has not provided confirmation to SingTel that the relevant Co-Located Equipment under Schedule 8D is operational; or
- (f) the Requesting Licensee submits a request under this Schedule 4B which seeks to activate capacity where the relevant link has not been activated or sought to have been activated.

3.8 For all types of Cable Systems:

- (a) the Requesting Licensee shall be responsible for all terminations at its own equipment and for providing the associated cabling and connectors between the Requesting Licensee's Equipment and SingTel's distribution frame in order to facilitate the physical termination of the link to SingTel's distribution frame; and
- (b) where work is to be carried out by SingTel under this Schedule, and the Charge is not defined under Schedule 9, the Requesting Licensee must pay all the costs incurred by SingTel in provisioning the Submarine Cable Connection Service to the Requesting Licensee, subject to the following conditions:
 - (i) the costs incurred by SingTel will relate to the work that SingTel needs to perform in order to provision the Submarine Cable Connection Service;
 - (ii) before incurring the costs, SingTel will provide the Requesting Licensee with prior reasonable notice that the Requesting Licensee's request requires SingTel to undertake such work and such notice shall clearly and with sufficient detail set out the following:
 - A. the reasonable costs which SingTel seeks to recover from the Requesting Licensee in respect of the costs incurred by SingTel in the following areas, as applicable to the specific provisioning work:
 - I. additional processing and implementation costs;
 - II. additional Project Study costs;
 - III. additional labour costs; and

- IV. additional equipment, software and hardware (including information system and software modification and testing); and
- B. based on the information set out in paragraph (ii)A, a binding quote to the Requesting Licensee in respect of the work to be undertaken by SingTel which shall be valid for a period of five (5) Business Days from the date they are notified to the Requesting Licensee by SingTel;
- (iii) SingTel shall obtain the prior approval of the Requesting Licensee to the costs noted in the notice within the time period under paragraph (ii)B and if the Requesting Licensee does not provide its approval within that time period, then SingTel may suspend SingTel's work under this paragraph (b) until the Requesting Licensee agrees; and
- (iv) any dispute in respect of determining the reasonable costs set out in the notice shall be resolved in accordance with Schedule 11 of the RIO Agreement.
- (c) SingTel shall advise the Requesting Licensee of the type of connectors, and the length of the associated cables referred to in paragraph (a) for the related capacity that is to be provisioned, within five (5) Business Days of its receipt of the LCAR Form; and
- (d) SingTel shall provide the distribution frame in connection with the routing of the Requesting Licensee's circuits to the Cable System and shall perform the physical termination of the Requesting Licensee's equipment or cabling to SingTel's distribution frame.
- 3.9 For Group B Cable Systems, SingTel shall provide the Cross Connection that is necessary only for routing the Requesting Licensee's circuits to the Cable System during the effective period of this Schedule.
- 3.10 The Requesting Licensee shall be responsible for the relevant Charges specified in Schedule 9 for the Connection Services provided in this Schedule 4B.
- 3.11 The Requesting Licensee must inform SingTel in writing of any changes in the information provided in the LCAR Form no less than three (3) Business Days prior to the requested date of activation of the link and/or capacity. SingTel shall not be obliged to activate the link and/or capacity if any changes to the

information in the LCAR Form have been provided to SingTel less than three (3) Business Days prior to the requested date of activation of the link and/or capacity.

3.12 SingTel shall be entitled to levy and receive the processing Charge specified in Schedule 9 for each LCAR Form that is rejected in accordance with this clause.

3.13 If procurement is required in order to meet the request pursuant to clause 3.2, SingTel shall:

(a) seek confirmation of the requested link and/or capacity from the Requesting Licensee;

(b) within four (4) Business Days of receipt of the LCAR Form, specify the date on which it is able to activate the requested link and/or capacity, which shall be no later than the timeframe within which it would reasonably activate such link and/or capacity for itself; and

(c) upon confirmation under clause 3.13(a), complete the required procurement and activate the requested link and/or capacity by the date specified in clause 3.13(b) above.

3.14 If procurement is required in order to meet the request pursuant to clause 3.2, SingTel shall not be liable for payment of any Service Level Guarantee payment payable under clause 1.7 where the delay in activation of the requested link and/or capacity is caused by failure to complete procurement in time due to events outside SingTel's reasonable control.

3.15 A minimum term of twelve (12) months shall apply to:

(a) each link activated in accordance with this clause 3, measured from the earlier of the Link Activation Date or Link-Capacity Activation Date (if applicable); or

(b) each link activated prior to the commencement of this Schedule 4B, measured from the date of commencement of that link under the relevant agreement,

(Link Term); and

(c) capacity activated on a Group B Cable System in accordance with an LCAR Form under this clause 3, measured from the earlier of the Capacity Activation Date or Link-Capacity Activation Date (if applicable); or

- (d) capacity activated on a Group B Cable System prior to the commencement of this Schedule 4B, measured from the date of commencement of that capacity under the relevant agreement,

(Capacity Term).

4. DELIVERY

4.1 A Requesting Licensee may request a deferment of the Link Activation Date, Capacity Activation Date, or Link Capacity Activation Date before SingTel has commenced activation work (**Deferment Request**). SingTel will accept a Deferment Request, provided that:

- (i) the Requesting Licensee pays SingTel a deferment fee equivalent to 50% of the Activation Charges set out in Schedule 9 of this RIO Agreement; and
- (ii) the revised Service Activation Date is no more than thirty (30) Business Days from the Service Activation Date notified in clause 3.2 of this Schedule 4B.

4.2 If a Requesting Licensee makes a Deferment Request for a revised Service Activation Date more than thirty (30) Business Days from the Service Activation Date notified in clause 3.2 of this Schedule 4B SingTel reserves the right to reject the Deferment Request and in such an event:

- (i) the Connection Service requested as specified in the relevant LCAR Form shall be deemed cancelled; and
- (ii) SingTel shall be entitled to levy and receive the processing Charge specified in Schedule 9 for each LCAR Form that is cancelled in accordance with this clause 4.2.

4.3 Notwithstanding clause 4.1 of this Schedule 4B, SingTel will not consider any Deferment Request submitted on or after the Service Activation Date notified in clause 3.2 of this Schedule 4B.

5. DEACTIVATION

5.1 If the Requesting Licensee wishes to deactivate a link and/or capacity under this Schedule 4B, it must submit a request for link deactivation and/or capacity

deactivation in the form of a Link Capacity Deactivation Request Form (**LCDR Form**) provided in Annex 4B-4. The LCDR Form must be provided to SingTel no less than four (4) Business Days prior to the intended Link Capacity Deactivation Date (**LCDD**). For the avoidance of doubt, in respect of Group B Cable Systems, a Requesting Licensee is permitted to request capacity deactivation together with deactivation of its associated link within one single request.

5.2 SingTel shall process the LCDR Form and advise the Requesting Licensee of its acceptance or otherwise within one (1) Business Day of its receipt. SingTel shall be entitled to levy and receive the processing Charge specified in Schedule 9 for each LCDR Form that is accepted in accordance with this clause 5.2.

5.3 SingTel may reject the LCDR Form if:

- (i) the request for link and/or capacity deactivation is not in the prescribed form specified in this clause;
- (ii) the request for link and/or capacity deactivation does not contain all the required information; or
- (iii) the request for link and/or capacity deactivation is less than four (4) Business Days prior to the LCDD.

5.4 SingTel shall be entitled to levy and receive the processing Charge specified in Schedule 9 for each LCDR Form that is rejected in accordance with this clause 5.

5.5 Where the LCDR Form is applicable to a link during the Link Term, the Requesting Licensee shall remain liable for the recurring Charges specified in Schedule 9 from the date of such deactivation (or partial deactivation if such is the extent of the LCDR Form) for the remainder of that Link Term.

5.6 In respect of Group B Cable Systems, where the LCDR Form is applicable to capacity during the Capacity Term, the Requesting Licensee shall be liable to SingTel for the recurring Charges specified in Schedule 9 from the date of such deactivation (or partial deactivation if such is the extent of the LCDR Form) for the remainder of that Capacity Term.

6. STANDARD TERMS AND CONDITIONS

6.1 The Requesting Licensee will:

- (a) promptly comply with all reasonable written notices or instructions given by SingTel in respect of the installation, use or operation of the Connection Service;
- (b) not use, attempt to use, nor permit any other person to use, the Connection Service in breach of any laws or regulations whatsoever, and will comply with all relevant directions and orders issued by the Authority from time to time; and
- (c) provide and install the associated cables between its own equipment and SingTel's Distribution Frame and terminate the associated cables to its own equipment.

6.2 SingTel will:

- (a) operate and maintain the Connection Service in accordance with international industry standards;
- (b) operate and maintain the Connection Service on no less favourable terms and conditions in which it operates and maintains comparable services provided to itself and its affiliates; and
- (c) exercise the reasonable skill and care of a competent telecommunications operator in performing its obligations under this Schedule and ensure that the Connection Service it provides to the Requesting Licensee is of the quality comparable to what it provides to itself and to its affiliates.

7. ACCESS AND APPROVALS REQUIRED

7.1 The Parties shall comply with clause 16.5 of the main body of this RIO Agreement in relation to the obtaining of all licences, permits, consents, waivers, authorisations and intellectual property or other rights required for the provision of the Connection Service.

8. OPERATIONS AND MAINTENANCE

8.1 Notification

Each Party shall as soon as practicable provide notification to the other Party in case of any fault or service interruption which is identified by the first-mentioned Party and to notify the other Party when the service is normalised.

8.2 Planned Maintenance

Each Party shall provide not less than fourteen (14) Calendar Days notice of any planned maintenance, which may affect the other Party's system and if SingTel is unable to give such notice for reasons beyond the reasonable control of SingTel, SingTel must provide notice as soon as reasonably practicable. Each Party shall use its reasonable endeavours to minimize disruption to the other Party.

8.3 Fault Resolution

- (a) If a fault or service interruption is identified to be caused by the Requesting Licensee, the point of contact is:

Requesting Licensee O&M Contacts:

Tel (office hour):

Tel (after office hour):

Fax:

Requesting Licensee Station Address:

- (b) If a fault or service interruption is identified to be caused by SingTel, the point of contact is:

SingTel's O&M Contacts:

Tel (office hour):

Tel (after office hour):

Fax:

SingTel's Cable Station Address :

8.4 Type Of Faults

Faults reported may be classified as follows:

- (i) Service affecting fault(s); and

- (ii) Non-service affecting fault(s).

Service affecting fault(s) may cause service interruption due to a system or physical link failure. Excessive data errors encountered on the links causing high data loss may also be classified as service affecting fault(s). Non-service affecting fault(s) are those that do not adversely affect data carried on the links.

8.5 Target Response Times

The target response time for attendance to an alarm or reported fault will depend on the time of its occurrence as contained in Table 1 below. "Office Hours" is defined as 8am to 5pm for Mondays to Fridays (except Public Holidays). The whole of Saturday, Sunday and any Public Holiday and the hours outside the Office Hours are referred to as "After Office Hours".

Fault Type	Response Time	
	During Office Hours	After Office Hours
Service Affecting	within one (1) hour of receipt of notification	within two (2) hours of receipt of notification
Non-Service Affecting	within two (2) hours of receipt of notification	within next Business Day of receipt of notification

Table 1 - Target Response Time

8.6 Fault Escalation

- (a) Where a fault persists and the Parties agree that progress of the remedy is not satisfactory, the fault may be escalated according to the fault escalation timescales and escalation reporting levels as outlined in sub-clauses 8.7 and 8.8 herein respectively.
- (b) The Parties shall immediately inform the first level of escalation within the respective Party's organisation at the same time when the Party which detected the fault notifies the fault reporting point of the Party for action.

8.7 Fault Escalation Timescales

The Parties shall use the following timescales as guidelines for the fault escalation process. The timescales shall be used in deciding whether the restoration of a fault is being progressing satisfactorily. If the escalation time has expired and both Parties are satisfied with the progress of the fault restoration, no immediate escalation is necessary.

Fault Type	Maximum Time For Escalation (Commencing after the Response Time)	
	First Level	Second Level
Service Affecting	Immediate	two (2) hours
Non-Service Affecting	Immediate	eight (8) hours

Table 2 – Fault Escalation Timescales

8.8 Escalation Reporting Levels

All requests for escalation shall be notified through each Party's fault reporting point. The reporting levels are :

Operator Escalation Level	SingTel	Requesting Licensee
First	Connection Service Engineer	to be advised by Requesting Licensee
Second	Connection Service Manager	to be advised by Requesting Licensee

Table 3 - Escalation Reporting Levels

8.9 Persistent or Repeated Faults

Persistent or repeated faults or issues which cannot be resolved satisfactorily through the normal channels of the Parties shall be escalated to the Second Level to expedite the fault clearance process.

8.10 Escalation Problems

The Parties shall notify their respective and appropriate officers stated in Table 3 above for problems encountered in the implementation or execution of the fault escalation procedures.

9. TERM

9.1 The Connection Service shall commence on the Link Activation Date or the Link Capacity Activation Date and continue until the earlier of the following events:

- (a) the expiry or termination of the licence for Co-Location Space in respect of the Co-Location Equipment at the relevant Submarine Cable Landing Station in accordance with Schedule 8D of this RIO Agreement;
- (b) upon expiry or termination of any licence in respect of other space acquired by the Requesting Licensee using the process contemplated in clauses 1.2 to 1.6 of Schedule 8 (as the case may be); or
- (c) no Co-Location Space is obtained by the Requesting Licensee within 90 Calendar Days of first application for a Request for Connection Service in respect of that Co-Location Space by the Requesting Licensee.

10. SUSPENSION

10.1 Subject to clauses 12.1 and 12.2 of the main body of this RIO Agreement, SingTel may suspend the Connection Service, capacity or link at any time until further notice to the Requesting Licensee if the Connection Service, capacity, link or licence in respect of the Submarine Cable Landing Station causes or is likely to cause physical or technical harm to any telecommunications network, system or services (whether of SingTel or any other person) including but not limited to causing damage, interfering with or causing deterioration in the operation of SingTel's Network.

10.2 Without limiting the exclusions or limitations of liability in this RIO Agreement, SingTel shall not be liable to the Requesting Licensee for any Loss resulting from, or in connection with, suspension of the Connection Service under this clause 10.

11. TERMINATION

11.1 Subject to clauses 13.1 and 13.2 of the main body of this RIO Agreement, SingTel may immediately terminate the Connection Service or any capacity or link provided in respect of a Cable System if:

- (a) the Requesting Licensee is no longer an FBO;
- (b) in SingTel's reasonable opinion, the Requesting Licensee is using the Connection Service in contravention of an applicable law, licence, code, regulation or direction and SingTel has the necessary confirmation from the relevant Governmental Agencies that the Requesting Licensee is in contravention of the applicable law, licence, code, regulation or direction;
- (c) in SingTel's reasonable opinion, the Requesting Licensee is using the Connection Service in a manner which places a Third Party in contravention of an applicable law, licence, code, regulation or direction and SingTel has the necessary confirmation from the relevant Governmental Agencies that the Third Party is in contravention of the applicable law, licence, code, regulation or direction;
- (d) the Connection Service is used by the Requesting Licensee for a purpose other than the purposes specified in clause 1.3;
- (e) the use of the Connection Service causes or is likely to cause physical or technical harm to any telecommunications network, system or services (whether of SingTel or any other person) including but not limited to causing damage, interfering with or causing deterioration in the operation of SingTel's Network; or
- (f) the letter of authorisation referred to in clause 3.5(a) is revoked.

11.2 Subject to clause 13.2 of the RIO Agreement, either Party (**Terminating Party**) may terminate the Connection Service if the other Party is in breach of this Schedule and such breach remains unremedied for a period of:

- (a) seven (7) Calendar Days after receiving notice from the Terminating Party to do so, if the breach is a service affecting breach; or
- (b) fourteen (14) Calendar Days after receiving notice from the Terminating Party to do so, if the breach is a non-service affecting breach (including but not limited to failure to pay any sum for which the Requesting Licensee has been Invoiced).

- 11.3 Upon expiry or termination of the Connection Service:
- (a) the Requesting Licensee must immediately discontinue the use of the Connection Service; and
 - (b) SingTel shall disconnect the Requesting Licensee's connectors terminated at SingTel's distribution frame; and
 - (c) the Requesting Licensee must immediately disconnect the connectors terminated at its distribution frame and remove the associated cabling between the Requesting Licensee's equipment and SingTel's distribution frame.
- 11.4 If the Requesting Licensee fails to disconnect and remove the associated cabling and connectors between the Requesting Licensee's equipment and SingTel's distribution frame under clause 11.3, SingTel shall remove the Requesting Licensee's associated cabling and connectors. The Requesting Licensee shall pay to SingTel all reasonable costs associated with the work undertaken by SingTel including the disposal of the Requesting Licensee's associated cabling and connectors. In such event, the Requesting Licensee shall have no claim whatsoever against SingTel.
- 11.5 If, prior to the expiry of any applicable Link Term and/or Capacity Term:
- (a) SingTel lawfully terminates the Connection Service, capacity or link in accordance with the terms of this Schedule; or
 - (b) the Connection Service is terminated or expires in accordance with clause 11.1,
- the Requesting Licensee shall be liable only for the recurring Charges for the relevant links and capacity for the remaining period of the applicable Link Term and/or Capacity Term.
- 11.6 This clause 11 survives termination of this Schedule 4B or this RIO Agreement.

ANNEX 4B.1

Connection Service diagram for Group A Submarine Cable Systems

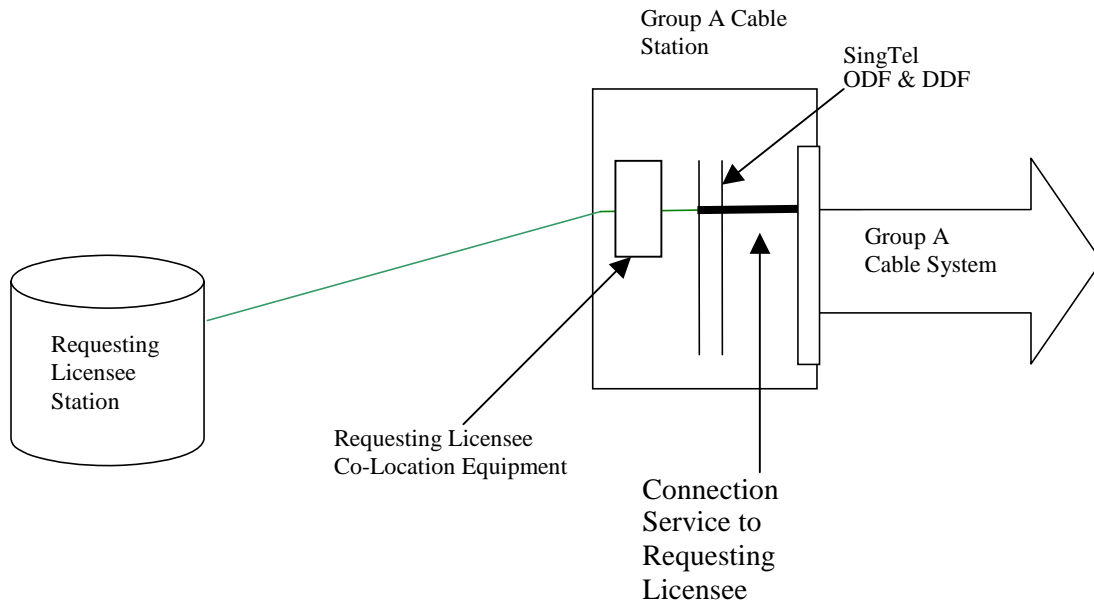

ANNEX 4B.2

Connection Service diagram for Group B Submarine Cable Systems

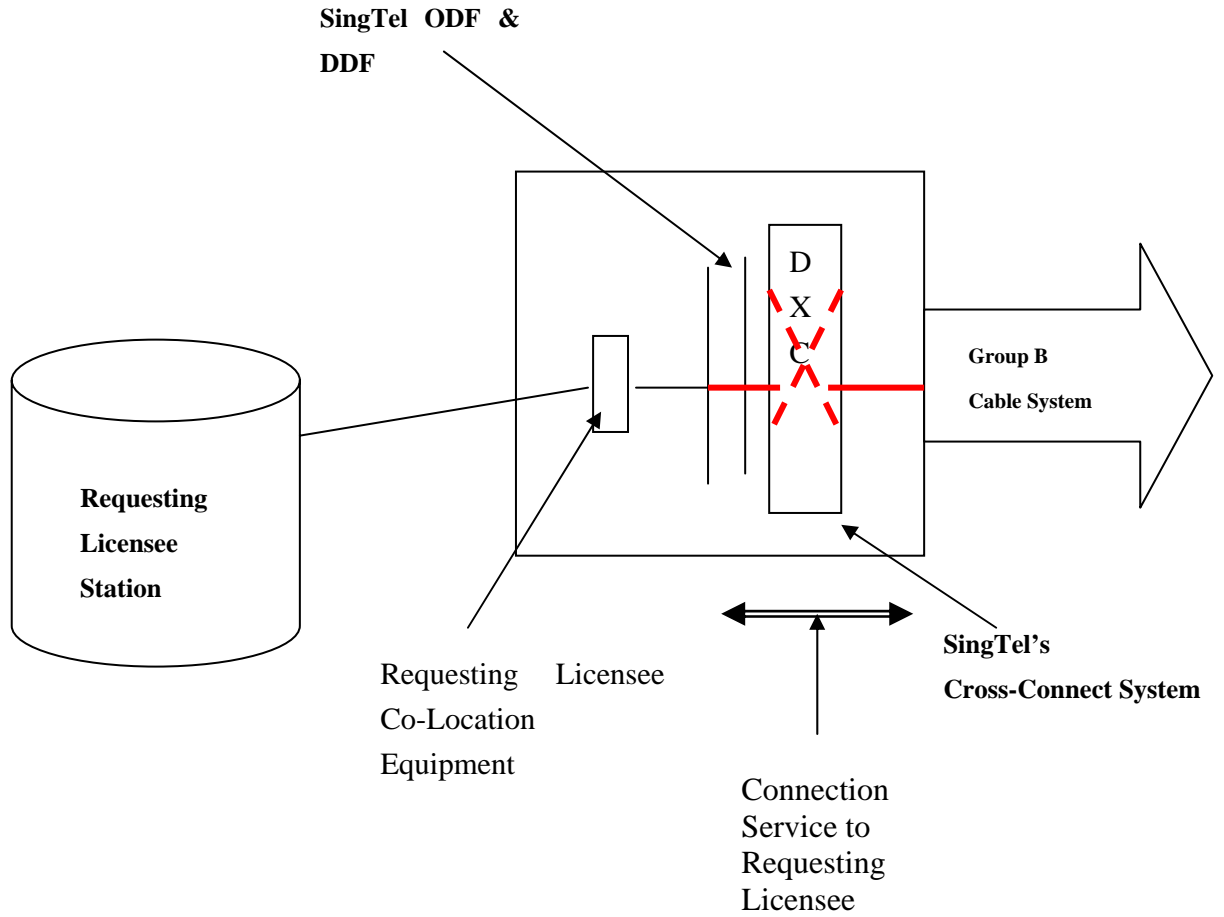



Link-Capacity Activation Request

Date:

To: Manager, Network Integration and Interconnect
 Fax: 65-6848 4113

1.	Requesting Licensee:											
	Name:	Please tick relevant box:										
	Signature:	<input type="checkbox"/> Link Activation Only										
	Telephone:	<input type="checkbox"/> Capacity Activation Only										
	Facsimile:											
	Company Stamp:	<input type="checkbox"/> Link and Capacity Activation										
2.	Submarine Cable System: Group A / Group B*											
	Link Particulars applicable to both Group A & B Cable Systems											
3a.	Link Connection Bit Rate:	Electrical Co-axial cable / Optical fibre *										
3b.	Capacity Designation:											
3c.	Cable System Circuit Allocation:											
3d.	Requesting Licensee's ODF/DDF Port Assignment:	Service link (SVR)/ Protection link (PRT)*										
3e.	Fibre/Co-axial Patch Cord Assignment: (SRV/PRT)	<table style="width: 100%; border-collapse: collapse;"> <thead> <tr> <th style="text-align: left; border-bottom: 1px solid black;">RL's ID</th> <th style="text-align: left; border-bottom: 1px solid black;">Patch No.</th> </tr> </thead> <tbody> <tr> <td style="border-bottom: 1px solid black;">/</td> <td style="border-bottom: 1px solid black;">/A -Tx(Svr)</td> </tr> <tr> <td style="border-bottom: 1px solid black;">/</td> <td style="border-bottom: 1px solid black;">/B - Rx(Svr)</td> </tr> <tr> <td style="border-bottom: 1px solid black;">/</td> <td style="border-bottom: 1px solid black;">/C - Tx(Prt) *</td> </tr> <tr> <td style="border-bottom: 1px solid black;">/</td> <td style="border-bottom: 1px solid black;">/D - Rx (Prt) *</td> </tr> </tbody> </table>	RL's ID	Patch No.	/	/A -Tx(Svr)	/	/B - Rx(Svr)	/	/C - Tx(Prt) *	/	/D - Rx (Prt) *
RL's ID	Patch No.											
/	/A -Tx(Svr)											
/	/B - Rx(Svr)											
/	/C - Tx(Prt) *											
/	/D - Rx (Prt) *											
3f.	Intended Link Activation Date:											
	Capacity Particulars applicable to Group B Cable Systems only											
4a.	Circuit Designation:											
4b.	Cable System's Circuit Allocation:											
4c.	Intended Capacity Activation Date:											
5.	Contacts for Test/Maintenance:	Name: Tel: Fax:										

6.	SingTel's Reply to the Requesting Licensee	Received Date: _____
	<input type="checkbox"/> Application returned –incomplete/illegible	
	<input type="checkbox"/> Not Approved	Reason for Rejection: _____
	<input type="checkbox"/> Approved	Activation Date: _____

*** Delete where not applicable – For the avoidance of doubt, the Service link does not include the Protection link.**



Link-Capacity Deactivation Request

Date:

To: Manager, Network Integration and Interconnect
 Fax: 65-6848 4113

1.	Requesting Licensee:											
	Name:	Please tick relevant box:										
	Signature:	<input type="checkbox"/> Link Deactivation Only										
	Telephone:	<input type="checkbox"/> Capacity Deactivation Only										
	Facsimile:	<input type="checkbox"/> Link and Capacity Deactivation										
	Company Stamp:											
2.	Submarine Cable System: Group A / Group B*											
	Link Particulars applicable to both Group A & B Cable Systems											
3a.	Link Connection Bit Rate:	Electrical Co-axial cable / Optical fibre *										
3b.	Capacity Designation:											
3c.	Cable System Circuit Allocation:											
3d.	Requesting Licensee's ODF/DDF Port Assignment:	Service link (SVR)/ Protection link (PRT)*										
3e.	Fibre/Co-axial Patch Cord Assignment: (SRV/PRT)	<table style="width: 100%; border-collapse: collapse;"> <thead> <tr> <th style="text-align: left; border-bottom: 1px solid black;">RL's ID</th> <th style="text-align: left; border-bottom: 1px solid black;">Patch No.</th> </tr> </thead> <tbody> <tr> <td style="border-bottom: 1px solid black;">/</td> <td style="border-bottom: 1px solid black;">/A -Tx(Svr)</td> </tr> <tr> <td style="border-bottom: 1px solid black;">/</td> <td style="border-bottom: 1px solid black;">/B - Rx(Svr)</td> </tr> <tr> <td style="border-bottom: 1px solid black;">/</td> <td style="border-bottom: 1px solid black;">/C - Tx(Prt) *</td> </tr> <tr> <td style="border-bottom: 1px solid black;">/</td> <td style="border-bottom: 1px solid black;">/D - Rx (Prt) *</td> </tr> </tbody> </table>	RL's ID	Patch No.	/	/A -Tx(Svr)	/	/B - Rx(Svr)	/	/C - Tx(Prt) *	/	/D - Rx (Prt) *
RL's ID	Patch No.											
/	/A -Tx(Svr)											
/	/B - Rx(Svr)											
/	/C - Tx(Prt) *											
/	/D - Rx (Prt) *											
3f.	Intended Link Deactivation Date:											
	Capacity Particulars applicable to Group B Cable Systems only											
4a.	Circuit Designation:											
4b.	Cable System's Circuit Allocation:											
4c.	Intended Capacity Deactivation Date:											
5.	Contacts for Test/Maintenance:	Name: Tel: Fax:										

6.

SingTel's Reply to the
Requesting Licensee

Received Date: _____

Application returned – incomplete/illegible

Not Approved

Reason for Rejection: _____

Approved

Deactivation Date: _____

*** Delete where not applicable – For the avoidance of doubt, the Service link does not include the Protection link.**

ANNEX 4B.5

CABLE SYSTEMS

- (a) Group A Cable Systems:
 - (i) APCN2 Cable System – for Co-Location Equipment located at the Katong Submarine Cable Landing Station;
 - (ii) C2C Cable System - for Co-Location Equipment located at the Changi Submarine Cable Landing Station;
 - (iii) i2i Cable System - for Co-Location Equipment located at the Tuas Submarine Cable Landing Station;
 - (iv) TIS Cable System - for Co-Location Equipment located at the Changi Submarine Cable Landing Station;
 - (v) SEA-ME-WE 4 Cable System - for Co-Location Equipment located at the Tuas Submarine Cable Landing Station; and
 - (vi) SEA-ME-WE 3 Cable System - for Co-Location Equipment located at the Tuas Submarine Cable Landing Station.

- (b) Group B Cable Systems:
 - (i) APCN Cable System - for Co-Location Equipment located at the Changi Submarine Cable Landing Station;
 - (ii) SEA-ME-WE 3 Cable System - for Co-Location Equipment located at the Tuas Submarine Cable Landing Station.

ANNEX 4B.6

SERVICE LEVEL GUARANTEES

1. REBATES FOR LINK CAPACITY ACTIVATION REQUEST TIMEFRAMES

Missed notification timeframe for response to Link Capacity Activation Request (clause 3.3 or 3.3(b)) by:	Rebate
1-30 Calendar Days	Number of days of delay x weekly recurring Charge
More than 30 Calendar Days	30 x weekly recurring Charge

2. PROVISIONING TIMEFRAMES

Missed timeframe for activation (clause 3.3(a) or 3.13(b)) by:	Rebate
1-30 Calendar Days	Number of days of delay x weekly recurring Charge
More than 30 Calendar Days	30 x weekly recurring Charge

3. (A) FAULT REPAIR QOS STANDARDS (FOR NON-SERVICE AFFECTING FAULTS)

Missed timeframe for fault rectification by:	Rebate
(i) 24 – 48 hours	weekly recurring Charge
(ii) 48 –72 hours	2 x weekly recurring Charge
(iii) More than 72 hours	3 x weekly recurring Charge

(B) FAULT REPAIR QOS STANDARDS (FOR SERVICE AFFECTING FAULTS)

Missed timeframe for fault rectification by:	Rebate
(i) 6 – 12 hours	weekly recurring Charge
(ii) 12 – 24 hours	2 x weekly recurring Charge
(iii) More than 24 hours	3 x weekly recurring Charge

Notes: Faults are classified as either:

- (i) Service affecting fault(s): may cause service interruption due to a system or physical link failure. Excessive data errors encountered on the links causing high data loss may also be classified as service affecting fault(s).
- (ii) Non-service affecting fault(s): those that do not adversely affect data carried on the links.

4. CLAIM PROCEDURES

- (a) A claim by the Requesting Licensee shall be made in writing within fourteen (14) Calendar Days of the completion of the relevant Calendar Month on which the QOS Standards are measured. The amount in respect of any claim shall be paid to the Requesting Licensee in the form of a rebate. The Requesting Licensee acknowledges that a failure to make a claim within the specified timeframes under this paragraph means that the Requesting Licensee waives any entitlement to the Service Level Guarantee payment in respect of that claim.
- (b) If the Requesting Licensee is entitled to a rebate pursuant to the claim made hereunder, then the amount of the rebate will be credited into the Requesting Licensee's account after it has been processed by SingTel and will be reflected in SingTel's bill to the Requesting Licensee in accordance with SingTel's billing cycle.
- (c) The guarantee and rebates provided by SingTel under this Annex 4B.6 are:
 - (i) of an ex-gratia nature and personal to the Requesting Licensee and are non-transferable; and
 - (ii) subject to this Schedule.
- (d) Despite anything to the contrary in this section, if the Requesting Licensee qualifies for any claim under this Annex 4B.6, SingTel shall honour its obligations in respect of that claim but in the event of a dispute as to whether the Requesting Licensee qualifies for a claim or as to the quantum of the claim payable to the Requesting Licensee, the dispute shall be resolved in accordance with the Dispute Resolution Procedures in Schedule 11 of the RIO, or in the case of a Billing Dispute, in accordance with Schedule 10 of the RIO.