

Annex A

SERVICE SCHEDULE - RESIDENTIAL PER-END-USER CONNECTION

NUCLEUS CONNECT PTE. LTD.
INTERCONNECTION OFFER (ICO) AGREEMENT
SERVICE SCHEDULE – RESIDENTIAL PER-END-USER CONNECTION

CONTENT PAGE

<u>No.</u>	<u>Paragraph</u>	<u>Page</u>
1.	INTRODUCTION	4
2.	DEFINITIONS AND INTERPRETATION.....	4
3.	COMMENCEMENT	5
4.	SERVICE REQUIRMENTS	6
5.	CHARGES	7

1. INTRODUCTION

- 1.1 This Service Schedule sets out the terms and conditions under which Nucleus Connect will provide the service known as Residential Per-End-User Connection (as defined below) to the Contracting QP.
- 1.2 This Service Schedule comprises the following:
 - (a) the provisions herein;
 - (b) the General Service Terms and Conditions and the following Appendices:
 - (i) Appendix 1: Provisioning Timeframe;
 - (ii) Appendix 2: Service Level Guarantees; and
 - (c) Orders submitted by the Contracting QP in relation to this Service Schedule.
- 1.3 In the event of any inconsistency or conflict between the provisions herein, the General Service Terms and Conditions and Orders submitted by the Contracting QP in relation to this Service Schedule, the order of precedence shall be as follows:
 - (a) the provisions herein;
 - (b) Orders submitted by the Contracting QP in relation to this Service Schedule; and
 - (c) the General Service Terms and Conditions.
- 1.4 The Master ICO Agreement, including the Annexes, shall apply unless and to the extent amended or supplemented by the provisions of this Service Schedule.
- 1.5 In this Service Schedule, a reference to a paragraph, unless stated otherwise, is to a paragraph of this Service Schedule.

2. DEFINITIONS AND INTERPRETATION

- 2.1 Unless otherwise defined herein this Service Schedule, all terms and expressions used herein will be construed to have the same meanings as found in the Master ICO Agreement and the General Service Terms and Conditions. Where a term or expression is defined specifically in this Service Schedule herein, the provisions herein shall prevail.
- 2.2 In this Service Schedule:

Class of Service or CoS means any of the following class of service:

- (a) Class A Real Time (Class A);
- (b) Class B Near Real Time (Class B);
- (c) Class C Mission Critical (Class C); or
- (d) Class D Best Effort (Class D),

each of which is prescribed QoS parameters as set out in the table in paragraph 4.2(c);

Committed Information Rate (CIR) means the minimum bandwidth that Nucleus Connect guarantees over the A-B segment of the diagram in the definition of “QoS”, for each Residential Per-End-User Connection;

Downlink means bandwidth in the downstream direction (from Aggregation Network to the End-User);

Peak Information Rate (PIR) means the maximum bandwidth that each Residential Per-End-User Connection can reach over the A-B segment of the diagram in the definition of “QoS”, in the absence of any sort of traffic aggregation, congestion or multiplexing;

Quality of Service or (QoS) means the service levels committed for ensuring delivery of services over the A-B segment of the diagram below, measured by Jitter, Latency and Packet Loss as set out in the table in paragraph 4.2(c);

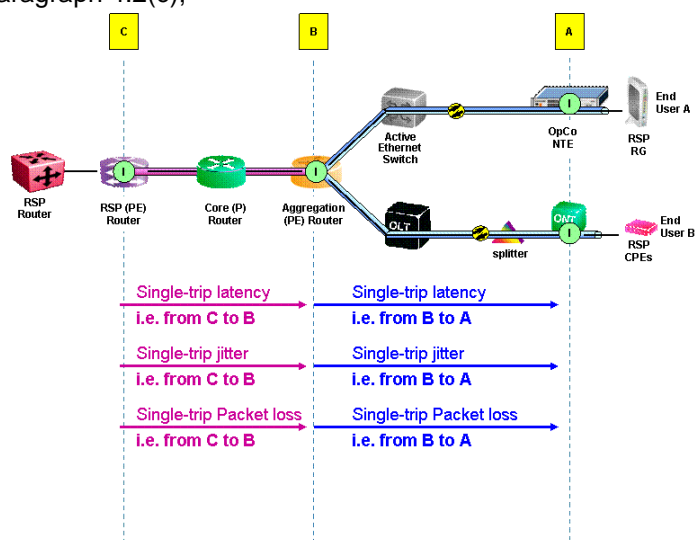

Residential Per-End-User Connection means one connection from the Aggregation Layer to the Service Port(s) in Nucleus Connect’s NTE at the Residential Premises specified by the Contracting QP in its Order, and “**Residential Per-End-User Connections**” means more than one End-User Connection;

Service Port means the physical port which the Contracting QP’s or End-User’s equipment shall interface to the Active Network for the purpose of receiving or using each Residential Per-End-User Connection; and

Uplink means bandwidth in the upstream direction (from the End-User to the Aggregation Network).

3. COMMENCEMENT

This Service Schedule shall commence with effect from the date that the Contracting QP first places an Order to take up a Residential Per-End-User Connection, in accordance with the General Service Terms and Conditions.

4. SERVICE REQUIREMENTS

4.1 The Contracting QP shall place one (1) Order for each Residential Per-End-User Connection. For example, if the Contractor wishes to take up two (2) Residential Per-End-User Connections, the Contracting QP shall submit two (2) separate Orders.

4.2 When placing an Order for a Residential Per-End-User Connection, the Contracting QP shall be required to:

- (a) Choose one Service Port type which is either Fast Ethernet (“**FE Service Port**”) or Gigabit Ethernet (“**GE Service Port**”). In the same Order, the Contracting QP may choose up to two additional Service Ports to be aggregated to the same Residential Per-End-User Connection provided that all the Service Ports are of the same type.

For FE Service Port(s), each Residential Per-End-User Connection will have a PIR of 100Mbps Downlink and 50Mbps Uplink.

For GE Service Port(s), each Residential Per-End-User Connection will have a PIR of 1Gbps Downlink and 500Mbps Uplink.

- (b) Choose any of the following Network Layers:

- (i) Option1: Layer 2 VLAN (IEEE 802.1q and IEEE Q-in-Q). Where there is more than one Service Port sharing the same Residential Per-End-User Connection, each Service Port shall have unique VLAN(s);

- (ii) Option 2: Layer 3 IPv4;

- (iii) Option 3: Layer 3 IPv6,

provided that the availability of Option 2 and Option 3 above are subject to the Contracting QP having taken up and completed the L3 Virtual Routing Domain Setup Service, which is an Ancillary Mandated Service provided by Nucleus Connect.

- (c) Subscribe to at least one Class of Service for such Residential Per-End-User Connection and indicate the total CIR it wishes to purchase in blocks of 5Mbps Downlink and/or 5Mbps Uplink, provided that:

- (i) the combined aggregate CIR for all subscribed Classes of Service shall be no more than 100Mbps Downlink and/or 50Mbps Uplink, for both FE Service Port and GE Service Port; and

- (ii) such Residential Per-End-User Connection shall have at least one (1) Class of Service with:

- (I) a minimum CIR of 25Mbps Downlink, in the case where the Service Port(s) are FE Service Port(s); or

- (II) a minimum CIR of 25Mbps Downlink and 10Mbps Uplink, in the case where the Service Port(s) are GE Service Port(s).

The Contracting QP may subsequently from time to time, increase or decrease the CIR of each Class of Service subscribed for such Residential Per-End-User Connection, in blocks of 5Mbps Downlink and/or 5Mbps Uplink, provided that sub-paragraphs (i) to (ii) above is complied with. Such increase or decrease of CIR shall constitute a Modification for which the

Contracting QP shall be required to submit an Order pursuant to and in accordance with the General Service Terms and Conditions.

The table below sets out the performance parameters of each Class of Service:

Class of Service	Jitter	Latency	Packet Loss
Class A Real Time	0.5ms	4ms	0.2%
Class B Near Real Time	1ms	8ms	0.2%
Class C Mission Critical	3ms	15ms	0.1%
Class D Best Effort	Best Effort	30ms	Best Effort

- 4.3 If the Contracting QP injects traffic into any Residential Per-End-User Connection which exceeds the CIR purchased for such Residential Per-End-User Connection pursuant to paragraph 4.2(c), the Contracting QP acknowledges and agrees that notwithstanding that Nucleus Connect will endeavour to deliver such excess traffic, such delivery is not guaranteed. For the avoidance of doubt, the Contracting QP shall not be able to inject traffic into any Residential Per-End-User Connection which exceeds the PIR as set out in paragraph 4.2(a).
- 4.4 The Contracting QP must adhere to Nucleus Connect’s QoS tagging scheme when sending or receiving data traffic through any Residential Per-End-User Connection from the relevant Service Port(s). Such QoS tagging scheme requires the use of priority bit value 5 for Class A, priority bit value 4 for Class B, priority bit value 2 for Class C and priority bit value 1 for Class D.
- 4.5 If the Contracting QP requires Nucleus Connect to perform QoS tagging on behalf of the Contracting QP, such tagging shall be on a one C-VLAN and one CoS per Service Port basis.
- 4.6 In relation to any Residential Per-End-User Connection taken up by the Contracting QP , if the Contracting QP wishes to:
- (a) change the then existing Service Port type in respect of such Residential Per-End-User Connection (from FE Service Port to GE Service Port or vice versa); and/or
 - (b) add or reduce the number of Service Ports aggregated to such Residential Per-End-User Connection, provided that the number of Service Ports sharing such Residential Per-End-User Connection shall not exceed three (3) at all times,

each such event shall constitute a Modification for which the Contracting QP shall be required to submit an Order pursuant to and in accordance with the General Service Terms and Conditions.

- 4.7 Nucleus Connect will make available to the Contracting QP the DHCP Option 82 Service in respect of the Residential Per-End-User Connections taken by the Contracting QP.

5. CHARGES

The Charges set out in this paragraph 5 are the rates payable by the Contracting QP on a Residential Per-End-User Connection basis.

5.1 Monthly Recurring NC Charges

Nucleus Connect will commence charging the Contracting QP the Monthly Recurring NC Charges specified below on the RFS Date.

Class Of Service	FE Service Port Monthly Recurring NC Charge (For first 25Mbps Downlink CIR)	GE Service Port Monthly Recurring NC Charge (For first 25Mbps Downlink CIR and 10Mbps Uplink CIR)	Applicable to both FE Service Port and GE Service Port	
			Monthly Recurring NC Charge (For each additional block of 5Mbps Downlink CIR)	Monthly Recurring NC Charge (For each additional block of 5Mbps Uplink CIR)
Class A Real Time	\$42	\$142	\$6	\$12
Class B Near Real Time	\$36	\$136	\$4	\$8
Class C Mission Critical	\$28	\$128	\$2	\$4
Class D Best Effort	\$21	\$121	\$1	\$2

If the Contracting QP requires an additional Service Port or additional two (2) Service Ports pursuant to paragraph 4.2(a), there will be an additional Monthly Recurring NC Charge of \$2 for each additional Service Port.

5.2 One-Time Charges

The Charges set out below are non-refundable once they are imposed on the Contracting QP by Nucleus Connect in the manner specified below. In addition, depending on when the relevant action is preferred by the Contracting QP to be undertaken by Nucleus Connect, the following multiplier factor will be applied to the NC Charges set out below. For the avoidance of doubt, the multiplier factor to be applied shall be one (1) unless the Contracting QP requests that the relevant action be undertaken by Nucleus Connect on off-working hours during Business Day(s) or on non Business Day(s).

	Period	Time		Multiplier Factor
Business Day	Monday to Friday	Working Hours	9.00am to 5.00pm	1
	Monday to Friday	Off-working hours	Before 9am and after 5.00pm	1.5
Non-Business day	Saturday, Sundays and Public Holidays	Throughout		2

(a) Cancellation Charge

Upon any Cancellation of any Order relating to Residential Per-End-User Connection, the following Charges shall be imposed on the Contracting QP:

- (i) an NC Charge of \$30;
- (ii) ON Charges, except those ON Charges which would be subject to paragraph 5.2(a)(iv), which have been incurred by Nucleus Connect, or which Nucleus Connect has committed to incur, at the time of such Cancellation;
- (iii) any Third Party Charges which have been incurred by Nucleus Connect, or which Nucleus Connect has committed to incur, at the time of such Cancellation; and
- (iv) any other third party charges, OpenNet's charges and/or ON Charges agreed pursuant to paragraph 5.2 or 6.3 of the General Service Terms and Conditions which have been incurred by Nucleus Connect, or which Nucleus Connect has committed to incur, at the time of such Cancellation.

(b) Installation Charge

Upon the installation of a Residential Per-End-User Connection by Nucleus Connect, the following Charges shall be imposed on the Contracting QP:

- (i) an NC Charge of \$50;
- (ii) ON Charges, except those ON Charges which would be subject to paragraph 5.2(b)(iv), which have been incurred by Nucleus Connect, or which Nucleus Connect has committed to incur, at the time of such installation;
- (iii) any Third Party Charges which have been incurred by Nucleus Connect, or which Nucleus Connect has committed to incur, at the time of such installation; and
- (iv) any other third party charges, OpenNet charges and/or ON Charges agreed pursuant to paragraph 5.2 or 6.3 of the General Service Terms and Conditions which have been incurred by Nucleus Connect, or which Nucleus Connect has committed to incur, at the time of such installation.

(c) Modification Charge

An NC Charge of \$30 shall be imposed on the Contracting QP upon the submission of a Modification Order by the Contracting QP.

(d) Maintenance or Repair

- (i) Nucleus Connect will charge for every onsite visit or joint investigation according to the length of time spent by Nucleus Connect's representative during such onsite visit or joint investigation respectively, if such onsite visit or joint investigation is requested by the Contracting QP. There will be a minimum NC Charge of \$130 per representative per onsite visit or joint investigation (as the case may

be) up to the first two hours. Subsequent hour blocks are charged at \$20 per representative.

- (ii) The No Fault Found Charge referred to in the General Service Terms and Conditions is \$350 per Fault report.

(e) Disconnection / Reconnection

Upon a disconnection and/or reconnection of a Residential Per-End-User Connection by reason of suspension pursuant to the ICO Agreement, the following NC Charges shall be imposed on the Contracting QP:

Description	NC Charges
Disconnection charge	\$30
Reconnection charge	\$15

(f) Deactivation

Upon the Deactivation of a Residential Per-End-User Connection, the following Charges shall be imposed on the Contracting QP:

- (i) the following NC Charges:

Description	NC Charges
Deactivation charge	\$30
Collection charge	\$12
Early Termination Charge	100% of remaining contract value

In relation to the abovementioned collection charge, it is a per-trip charge to the same service address for collection of Nucleus Connect's equipment at the End-User Premises;

- (ii) ON Charges, except those ON Charges which would be subject to paragraph 5.2(f)(iv), which have been incurred by Nucleus Connect, or which Nucleus Connect has committed to incur, at the time of such Deactivation;
- (iii) any Third Party Charges which have been incurred by Nucleus Connect, or which Nucleus Connect has committed to incur, at the time of such Deactivation; and
- (iv) any other third party charges, OpenNet's charges and/or ON Charges agreed pursuant to paragraph 5.2 or 6.3 of the General Service Terms and Conditions which have been incurred by Nucleus Connect, or which Nucleus Connect has committed to incur, at the time of such Deactivation.

Application Form

Residential Per-End-User Connection



ATTN: NUCLEUS CONNECT, ORDER DESK
 FACSIMILE NO. : (65) 6808 2820
 EMAIL: orderdesk@nucleusconnect.com

Type of Order

New Order
 Modification
 Deactivation
 Others (Please specify): _____
 Existing Service ID (Mandatory field unless New Order): _____

Business Customer Information

Company Details	Authorised Officer Particulars
Name of Firm/Company as in RCB:	Name of Authorised Officer as in NRIC/PASSPORT/FIN*. Please underline surname. (Dr/Mr/Miss/Mrs/Mdm):_
Registered Address as in RCB:	NRIC/PASSPORT/FIN* No. of Authorised Officer (Dr/Mr/Miss/Mrs/Mdm):
	E-mail of Authorized Officer:
Main Office Contact No.:	Designation:
Main Office Fax No.:	Contact No. (Office):_
Business Registration Number (BRN):	Contact No. (Fax):
Account Information (For New Accounts, please refer to www.nucleusconnect.com for instruction to sign up Nucleus Connect's Services)	Account Number:
Customer Reference ID : (This ID is issued by customer for their internal reference of the service that is set out in this application form)	

Billing Details (If different from Business Customer Information)

Company Name:	Billing Address :_
City & Postal Code:	Country:
Contact Person Name (Billing):	Customer Contact Number :
Customer Fax Number:	E-mail:

* Please select where appropriate

Customer Technical Contact

Installation Contact (for service delivery)	Operations/Technical Contact (after service delivery)
Name:	Name:
Telephone (O):	Telephone (O):
Mobile:	Mobile:
Email:	Email:
Notification Mode: 24 Hours Daily <input type="checkbox"/> Office Hours (9am-5pm, Mon-Fri) <input type="checkbox"/>	Notification Mode: 24 Hours Daily <input type="checkbox"/> Office Hours (9am-5pm, Mon-Fri) <input type="checkbox"/>

Application Form

Residential Per-End-User Connection



Instruction					
<p>Bandwidth option: The Order Form shall only reflect the final CoS/CIR combination to be effected by this Order. At all times, the Residential Per-End-User Connection must have at least one Class of Service with:</p> <p>(i) a minimum Committed Information Rate (CIR) of 25Mbps Downlink, in the case where the Service Port(s) are FE Service Port(s); or</p> <p>(ii) a minimum Committed Information Rate (CIR) of 25Mbps Downlink and 10Mbps Uplink, in the case where the Service Port(s) are GE Service Port(s).</p> <p>Note: Unique VLAN shall be assigned for each service port; no two service ports shall share the same VLAN.</p>					
Type of Service Port					
<input type="checkbox"/> Fast Ethernet UTP(100Mbps) over GPON <input type="checkbox"/> Gigabit Ethernet UTP(1Gbps) over GPON <input type="checkbox"/> Others: _____ <input type="checkbox"/> Additional Service Ports: _____ (Aggregated to the same End-User-Connection)					
Service Port Installation Address		Address:		Postal Code:	
Site Contact:		Name:		Contact number:	
Network Layer Configuration					
Network protocol options <input type="checkbox"/> L2 VLAN IEEE802.1q <input type="checkbox"/> L2 VLAN IEEE q-in-q <input type="checkbox"/> Layer 3 IPV4 <input type="checkbox"/> Layer 3 IPV6 <input type="checkbox"/> untagged					
Class Of Service	Committed Information Rate per CoS (Multiple of 5Mbps)	VLAN ID assigned to per CoS	Class Of Service	Committed Information Rate per CoS (Multiple of 5Mbps)	VLAN ID assigned to per CoS
CoS: _____	Bandwidth: _____	VLAN : _____	CoS: _____	Bandwidth: _____	VLAN : _____
CoS: _____	Bandwidth: _____	VLAN : _____	CoS: _____	Bandwidth: _____	VLAN : _____
Service Destination at Aggregation	<input type="checkbox"/> PB-EVC Svc ID: _____ <input type="checkbox"/> PB-EVC Svc ID: _____ <input type="checkbox"/> PB-EVC Svc ID: _____		<input type="checkbox"/> AG-EVC Svc ID: _____ <input type="checkbox"/> AG-EVC Svc ID: _____ <input type="checkbox"/> AG-EVC Svc ID: _____		<input type="checkbox"/> IP Multicast ID: _____ <input type="checkbox"/> IP Multicast ID: _____
Dynamic routing information (BGP Configuration)			Static Routing information PE: Provider Equipment; CE: Customer Equipment		
<input type="checkbox"/> L3 Virtual Routing Domain: _____ <input type="checkbox"/> VLAN: _____ <input type="checkbox"/> BGP ASN: _____ <input type="checkbox"/> MD5 Password: _____		<input type="checkbox"/> Prefix1: _____ <input type="checkbox"/> Prefix2: _____ <input type="checkbox"/> Prefix3: _____ <input type="checkbox"/> Additional Attachment: _____		<input type="checkbox"/> L3 Virtual Routing Domain: _____ <input type="checkbox"/> VLAN: _____ PE-CE IP subnet: _____ CE LAN IP Subnet: _____ <input type="checkbox"/> Additional Attachment: _____	
Service Port Configuration					
Service Port A: VLAN: _____		Service Port B: VLAN: _____		Service Port C: VLAN: _____	
Contract Period					
Minimum Term [Ⓐ]	<input type="checkbox"/> 12 months <input type="checkbox"/> Others (Please specify): _____				
Customer requested RFS Date [Ⓑ]					
OpenNet Appointment Date [Ⓓ]	Date:	Slot: AM <input type="checkbox"/>	PM <input type="checkbox"/>		
Nucleus Connect Appointment Date ^{**#}	Date:	Slot: AM <input type="checkbox"/>	PM <input type="checkbox"/>	EVENING [®] (After 5pm) <input type="checkbox"/>	
Additional Information					

[Ⓐ] Subject to agreement, resource availability and confirmation by Nucleus Connect.

[Ⓑ] If Minimum Term is not specified, the Contracting QP shall be deemed to have selected 12 months.

[Ⓒ] Timeslot is not available on weekends and public holidays.

[#] NC Multiplier factor / OpenNet Onsite Charges shall apply accordingly.

[Ⓓ] OpenNet appointment is required if there is a installation of a termination point

^{**} When there is a termination point installation, Nucleus Connect's appointment shall be no more than 3 Business Days after OpenNet's appointment date.

Application Form

Residential Per-End-User Connection



Customer Signature		
<p>We hereby agree to subscribe to the abovementioned services on the terms and subject to the conditions contained in the Master ICO Agreement and the Service Schedule for the abovementioned services, which terms and conditions shall apply upon Nucleus Connect's acceptance of this application. We certify that all information provided by us herein are true, correct and complete. Further, we agree that any cancellation of the abovementioned services may result in a charge to us at Nucleus Connect's prevailing rates.</p>		
<u>Signature of Authorised Officer</u>	<u>Date</u>	<u>Company Stamp</u>
For Nucleus Connect Use		
<input type="checkbox"/> Application Rejected:	Reason for rejection:	
<input type="checkbox"/> Application Accepted	Service ID/s:	Work Order No.:
No. of pages attached (Excluding application forms):	Approval code:	Processed by (Name, Contact, Signature and Date)