



Broadband Point to Multipoint Trial Report

Released 1.5

8 January 2001.

TABLE OF CONTENTS

<u>INTRODUCTION</u>	5
<u>1 LMDS TECHNOLOGY OVERVIEW</u>	6
1.1 <u>DEFINITION</u>	6
1.2 <u>KEY ADVANTAGES OF LMDS</u>	6
<u>2 PACIFIC INTERNET’S LMDS TRIAL</u>	7
2.1 <u>INTRODUCTION</u>	7
2.2 <u>TRIAL OBJECTIVE</u>	7
<u>3 PACIFIC INTERNET’S LMDS TRIAL AT CENTRAL BUSINESS DISTRICT (CBD)</u>	9
3.1 <u>TRIAL LOCATION</u>	9
3.2 <u>TRIAL SET-UP</u>	10
<u>4 LMDS COMMISSIONING FOR CBD TRIAL</u>	11
4.1 <u>OVERALL NETWORK SET-UP</u>	11
4.2 <u>FREQUENCY ALLOCATION</u>	12
4.2.1. <u>Base Station (BS) Configuration Parameters</u>	12
4.2.2. <u>Remote Station (RS) Configuration</u>	12
4.3 <u>BASE STATION (BS) COMMISSIONING</u>	13
4.3.1. <u>Objectives</u>	13
4.3.2. <u>Installation Procedure</u>	13
4.3.3. <u>Test Result</u>	13
4.4 <u>REMOTE STATION COMMISSIONING</u>	14
4.4.1. <u>Remote Station Antenna Alignment</u>	14
4.4.2. <u>Remote Station Equipment (RSE) Installation</u>	16
<u>5 NETWORK MANAGEMENT SYSTEM (NMS) TESTS FOR CBD TRIAL</u>	17
5.1 <u>SYSTEM SET-UP TEST</u>	17
5.1.1. <u>Objective</u>	17
5.1.2. <u>Test Procedure</u>	17
5.1.3. <u>Test result</u>	17
5.2 <u>CONNECTION SET-UP TEST</u>	18
5.2.1. <u>Objective</u>	18
5.2.2. <u>Test Procedure</u>	18
5.2.3. <u>Test Result</u>	18
<u>6 LMDS NETWORK TEST FOR THE CBD TRIAL</u>	19
6.1 <u>PRIMARY RATE CIRCUIT EMULATION TEST</u>	20
6.1.1. <u>Objective</u>	20
6.1.2. <u>Test Procedure</u>	20
6.1.3. <u>Test Result</u>	21
6.2 <u>ETHERNET SERVICE TEST (BSE TO RSE)</u>	23
6.2.1. <u>Objective</u>	23
6.2.2. <u>Test Procedure</u>	23
6.2.3. <u>Test Result</u>	24
6.3 <u>ETHERNET SERVICE TEST (RSE 1 TO RSE 2)</u>	25
6.3.1. <u>Objective</u>	25
6.3.2. <u>Test Procedure</u>	25
6.3.3. <u>Test Result</u>	26
6.4 <u>SIMULTANEOUS E1 AND 10BT CONNECTION</u>	27
6.4.1. <u>Objective</u>	27

6.4.2.	<i>Test procedure</i>	27
6.4.3.	<i>Test Result</i>	28
7	<u>APPLICATION TEST FOR CBD TRIAL</u>	29
7.1	<u>BASIC INTERNET APPLICATION TEST</u>	29
7.1.1.	<i>Objective</i>	29
7.1.2.	<i>Test Procedure</i>	29
7.1.3.	<i>Test Result</i>	30
7.2	<u>VIDEO STREAMING TEST</u>	31
7.2.1.	<i>Objective</i>	31
7.2.2.	<i>Test Procedure</i>	31
7.2.3.	<i>Test Result</i>	32
7.3	<u>VIDEO CONFERENCING TEST</u>	33
7.3.1.	<i>Objective</i>	33
7.3.2.	<i>Test Procedure</i>	33
7.3.3.	<i>Test Result</i>	34
7.4	<u>SYMMETRICAL DIGITAL SUBSCRIBER LINE (SDSL) TEST</u>	35
7.4.1.	<i>Objective</i>	35
7.4.2.	<i>Test Procedures</i>	35
7.4.3.	<i>Test Result</i>	36
7.5	<u>BROADBAND REMOTE ACCESS SERVICE (RAS) TEST</u>	37
7.5.1.	<i>Objective</i>	37
7.5.2.	<i>Test Procedure</i>	37
7.5.3.	<i>Test Result</i>	38
7.6	<u>FRACTIONAL EI TESTS (LOOPBACK)</u>	39
7.6.1.	<i>Objective</i>	39
7.6.2.	<i>Test Procedure</i>	39
7.6.3.	<i>Test result</i>	40
7.7	<u>VOICE TEST</u>	41
7.7.1.	<i>Objective</i>	41
7.7.2.	<i>Test Procedure</i>	41
7.7.3.	<i>Test result</i>	42
8	<u>PACIFIC INTERNET'S LMDS TRIAL AT SCIENCE PARK AREA</u>	43
8.1	<u>TRIAL LOCATION</u>	43
8.2	<u>TRIAL SET-UP</u>	44
9	<u>LMDS COMMISSIONING FOR THE SCIENCE PARK TRIAL</u>	45
9.1	<u>OVERALL NETWORK SET-UP</u>	45
9.2	<u>FREQUENCY ALLOCATION</u>	46
9.2.1.	<i>Base Station (BS) Configuration Parameters</i>	46
9.2.2.	<i>Remote Station (RS) Configuration</i>	46
9.3	<u>BASE STATION COMMISSIONING</u>	47
9.3.1.	<i>Installation verification</i>	47
9.3.2.	<i>BTS IF Cables System Loss Calibration</i>	47
9.4	<u>REMOTE STATION COMMISSIONING</u>	49
9.4.1.	<i>CPE Antenna Alignment</i>	49
9.4.2.	<i>Remote Station Equipment (RSE) configuration</i>	50
10	<u>NETWORK MANAGEMENT SYSTEM (NMS) TESTS FOR THE SCIENCE PARK TRIAL</u>	
	51	
10.1	<u>SYSTEM SET-UP TEST</u>	51
10.1.1.	<i>Objectives</i>	51
10.1.2.	<i>Test Procedure</i>	51
10.1.3.	<i>Test Result</i>	51
11	<u>LMDS NETWORK TEST FOR THE SCIENCE PARK TRIAL</u>	52

11.1	<u>PRIMARY RATE CIRCUIT EMULATION TEST</u>	53
<u>11.1.1.</u>	<i>Objective</i>	53
<u>11.1.2.</u>	<i>Test Procedure</i>	53
<u>11.1.3.</u>	<i>Test Results</i>	54
11.2	<u>ETHERNET SERVICE TEST</u>	55
<u>11.2.1.</u>	<i>Objective</i>	55
<u>11.2.2.</u>	<i>Test Procedure</i>	55
<u>11.2.3.</u>	<i>Test Result</i>	56
11.3	<u>FADE MARGIN TEST</u>	57
<u>11.3.1.</u>	<i>Objectives</i>	57
<u>11.3.2.</u>	<i>Test Procedure</i>	57
<u>11.3.3.</u>	<i>Test Results</i>	57
11.4	<u>CROSS BAND INTERFERENCE</u>	59
<u>11.4.1.</u>	<i>Objectives</i>	59
<u>11.4.2.</u>	<i>Test Procedure</i>	59
<u>11.4.3.</u>	<i>BTS Test Results</i>	59
12	<u>APPLICATION TEST FOR THE SCIENCE PARK TRIAL</u>	60
12.1	<u>BASIC INTERNET APPLICATION TEST</u>	60
<u>12.1.1.</u>	<i>Objective</i>	60
<u>12.1.2.</u>	<i>Test Procedure</i>	60
<u>12.1.3.</u>	<i>Test Result</i>	61
12.2	<u>VIDEO STREAMING TEST</u>	62
<u>12.2.1.</u>	<i>Objective</i>	62
<u>12.2.2.</u>	<i>Test Procedure</i>	62
<u>12.2.3.</u>	<i>Test Result</i>	62
12.3	<u>VIDEO CONFERENCING TEST</u>	63
<u>12.3.1.</u>	<i>Objective</i>	63
<u>12.3.2.</u>	<i>Test Procedure</i>	63
<u>12.3.3.</u>	<i>Test Result</i>	64
12.4	<u>FRACTIONAL EI TESTS (LOOPBACK)</u>	65
<u>12.4.1.</u>	<i>Test Objectives</i>	65
<u>12.4.2.</u>	<i>Test Description</i>	65
<u>12.4.3.</u>	<i>Test result</i>	66
12.5	<u>VOICE TEST</u>	67
<u>12.5.1.</u>	<i>Objective</i>	67
<u>12.5.2.</u>	<i>Test Procedure</i>	67
<u>12.5.3.</u>	<i>Test result</i>	68
13	<u>SUMMARY</u>	69

Introduction

Pacific Internet Ltd., Singapore (PI) is the leading provider of Internet access and Internet Services in the Asia Pacific regions. Currently, it is the only Asia-Pacific Internet Service Provider (ISP) that has operations in Singapore, Hong Kong, Philippines, Australia, India and Thailand.

With the advent of the telecommunications industry liberalisation announced this January by the Infocomm Development Authority (IDA), companies (both local and foreign) are now allowed to apply for licenses to provide both service based or facilities based telecommunication services in Singapore starting from April 1, 2000.

“Broadband Point to Multipoint” is a wireless technology that allows providers such as Pacific Internet to provide direct voice and broadband data access to end customers by deploying its own last mile infrastructure rapidly and effectively. In the USA, this technology is generally known as Local Multipoint Distribution Services (LMDS). In this report, we will use LMDS as the abbreviation for the Broadband point-to-multipoint technology.

1 LMDS Technology Overview

1.1 Definition

Local Multipoint Distribution Services (LMDS) is a point to multipoint fixed broadband wireless transmission technology. It mainly utilises frequency spectrum from 10GHz to 38GHz ranges. This term is broadly used in the USA. Some other countries such as Canada may have a slightly different acronym such as LMCS (Local Multipoint Communications System) for the same technology. LMDS Equipment had currently been deployed in many developed countries such as USA, France and Hong Kong. With this new technology, a service provider such as Pacific Internet can provide alternative broadband access capabilities to all customers within its coverage area.

1.2 Key advantages of LMDS

- This technology provides the opportunity for new facility-based players in Singapore to set-up the necessary last mile access infrastructure to end customers quickly and effectively. The conventional wireline infrastructure requires an extended period of time for any sizeable rollout especially in the densely populated CBD area. With LMDS technology, it eliminates the need to dig road at every junction of Singapore and to lay physical cables to every single building right from day one.
- With this technology, the infrastructure rollout can be scaled easily based on the demand in the market. A new building can be transformed into a broadband-ready tower within days using this technology. As a result, a “build-on-demand” model can be implemented easily with LMDS.
- This technology can serve as an excellent transport medium for a full range of integrated narrowband and broadband services (voice, data and video).
- LMDS allows PI to provide the last mile alternative to the incumbents for any potential broadband-hungry customers. It eliminates PI’s dependency on the incumbents, and hence, enables us to control the end-to-end QOS for any services offered to our customers.

2 Pacific Internet's LMDS Trial

2.1 Introduction

In early year 2000, a selected number of new infrastructure providers in countries such as USA, Canada and Hong Kong had completed their LMDS trials successfully. However, none of the trials were conducted in countries located in the "Rain Region P" area. Singapore is one of countries located in this region. As "Rain region P" is one of the regions with the highest rainfall density (mm/hr), there is scepticism whether LMDS is a feasible technology for Singapore environment. Furthermore, as LMDS operates in the high-end microwave spectrum (greater than 10GHz), it limits the coverage area to a very small cell radius.

In view of the potential advantages of the LMDS technology, Pacific Internet applied and subsequently obtained the LMDS Trial license from IDA in early February 2000. Two simultaneous trials were conducted successfully by Pacific Internet. Central Business District (CBD) area was selected as one of the key trial site for PI. The second trial was conducted in the Science Park area.

2.2 Trial Objective

With LMDS, a new infrastructure provider like PI is able to compete competitively with the incumbents for a wide range of products and services with high Quality of Services.

The Main Goals for the LMDS Trial:

- ◆ To evaluate LMDS technology and assess all possible environmental and non-environment impacts on this system operating in the rain region P. Currently, there is no official LMDS trial report for the tests conducted in this particular rain region yet.
- ◆ To gain the necessary experience and expertise in rolling out broadband wireless infrastructure using LMDS technology in the near future.
- ◆ To conduct a variety of application tests to ensure that such technology is scalable in supporting PI's vast number of data and voice-related services.

- ◆ To evaluate the business viability of the LMDS deployment in the Singapore market.

The two trials will be described in details in the following chapters.

3 Pacific Internet's LMDS Trial at Central Business District (CBD)

3.1 Trial Location

CBD area is one of the key target areas of Pacific Internet for its LMDS commercial deployment. As a result, in order to simulate the actual LMDS deployment processes during this trial, PI selected a number of CBD buildings for this trial. With all the necessary experience learned from this trial, PI hopes to minimise any major obstacles during the actual commercial deployment stage, should PI obtain the official LMDS spectrum from IDA later this year.

Table 3.1 showed the detail information of the three sites covered in this CBD trial.

Site Name	OUB Building	Suntec City	The Heeren
Function	Base Station	Remote Station	Remote Station
Address	1 Raffles Place, #040-02, OUB Centre, Singapore 048616	7 Temasek Boulevard, Suntec Tower One Singapore 038987	260 Orchard Road, The Heeren, Singapore 238855
Latitude	N01'17'095	N 01'17'730	N 01'18'512
Longitude	E103'51'061	E 103'51'512	E 103'50'295
Distance from Base station (km)	0	1.6	2.4

TABLE 3.1

Rain Region P is one of the worst rain regions in the world. In order to maintain the same QoS, the distance between the Base station and remote station will be shortened as we progress from Rain region A to rain region Q. Theoretically, the maximum distance between the base station and remote station is slightly more than 1km for rain region P. Pacific Internet had intentionally stretched the theoretical limit to 2.4km in this trial. This allows PI to evaluate the rain effect on this technology and

subsequently facilitate its cell-planning task during the commercial deployment.

3.2 Trial Set-up

Two sectorial antennas were installed on the rooftop of the base station located at OUB building.

Two remote stations were chosen for their clear Line of Sight (LOS) excellent distance to OUB buildings. Suntec City is within the coverage area of sector 1 whereas The Heeren is located within sector 2 coverage.

At The Heeren, 2 Remote Station boxes were connected to the same radio antenna.

The full network configuration of the trial would be illustrated in greater detail in the next chapter.

4 LMDS Commissioning for CBD Trial

4.1 Overall Network Set-up

Figure 4.1 below illustrated the overall network set-up for the trial conducted in the CBD area. The detail of the each test would be further described in Chapter 5.

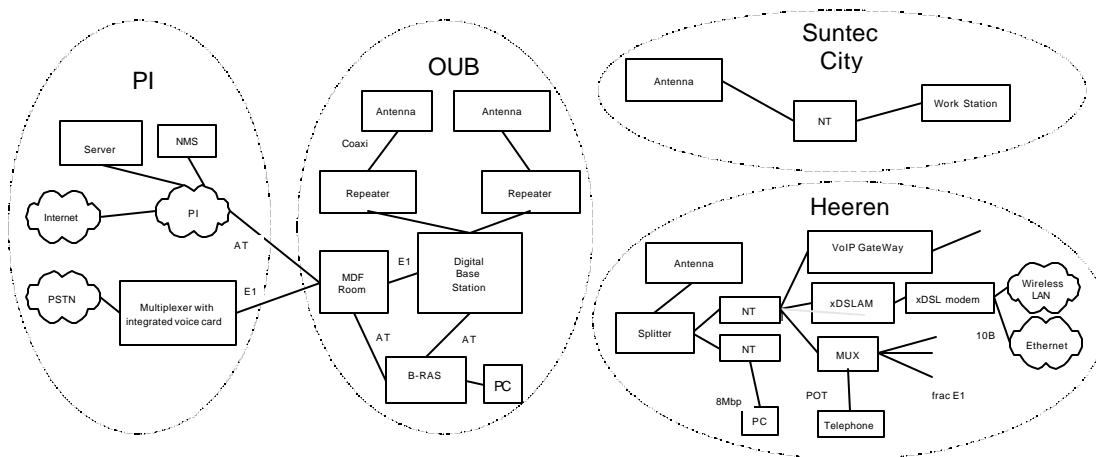

FIGURE 4.1

4.2 Frequency Allocation

4.2.1. Base Station (BS) Configuration Parameters

	Sector 1	Sector 2
Direction	To Suntec City	To The Heeren
Sectorial Antenna Type	90 degrees	90 degrees
Downlink RF Start (GHz)	28.0	28.028
Downlink RF End (GHz)	28.028	28.056
Uplink RF Start (GHz)	27.5	27.528
Uplink RF End (GHz)	27.514	27.535

4.2.2. Remote Station (RS) Configuration

	Suntec City	The Heeren
No. of Transceiver Antennas	1	1
Distance to Base Station (km)	1.6	2.4

4.3 Base Station (BS) Commissioning

4.3.1. Objectives

To verify that BS equipment had been fully installed as per the instructions contained in the LMDS equipment Installation manual. The equipment included the Base Station Equipment (BSE) and the antenna.

4.3.2. Installation Procedure

- The installation procedure stated in the Base Station Technical Description manual was reviewed.
- Some of the major tasks included antenna azimuth and elevation verification and adjustments, grounding, lightning protection and cable type confirmation.
- The Base Station Equipment (BSE) was set-up as described in the installation manual.
- Verified that all cabling task was completed.
- Verified that the antennas were mounted on the polls at the precise location selected by the site acquisition team.
- Verified that all the card modules and the antenna were installed correctly with the Network Management System (NMS). The detail of the NMS would be further illustrated in chapter five later.

4.3.3. Test Result

Installation was completed as per documentation. No critical event was detected with the NMS when the BSE was power-on.

4.4 Remote Station Commissioning

The main objective of this test was to verify that the remote station equipment had been fully installed as per the instructions contained in the Remote Station Installation manual.

Some of the main installation items include:

Remote Station Equipment – standard 1U, 19” rack equipment, rack-mounted or wall-mounted

Radio Termination (RT) – To convert the Intermediate Frequency (IF) to Radio Frequency (RF). The RT is normally installed next to the antenna on the rooftop.

Antenna - 26 cm (diameter) parabolic antenna installed on the rooftop. Wall-mounted or poll-mounted.

4.4.1. Remote Station Antenna Alignment

4.4.1.1. Objective

To align every antenna in the trial network for optimal performance.

4.4.1.2. Test Procedure

- The Remote Installation Tool (RIT) was used to calculate the parameters of the antennas and downloaded them to the antennas.
- The Remote Station antenna alignment was tuned using RIT as shown in Figure 4.4 below.
- The receive power level at the Remote Station was examined with a spectrum analyser. The same procedure was repeated for each remote station site.

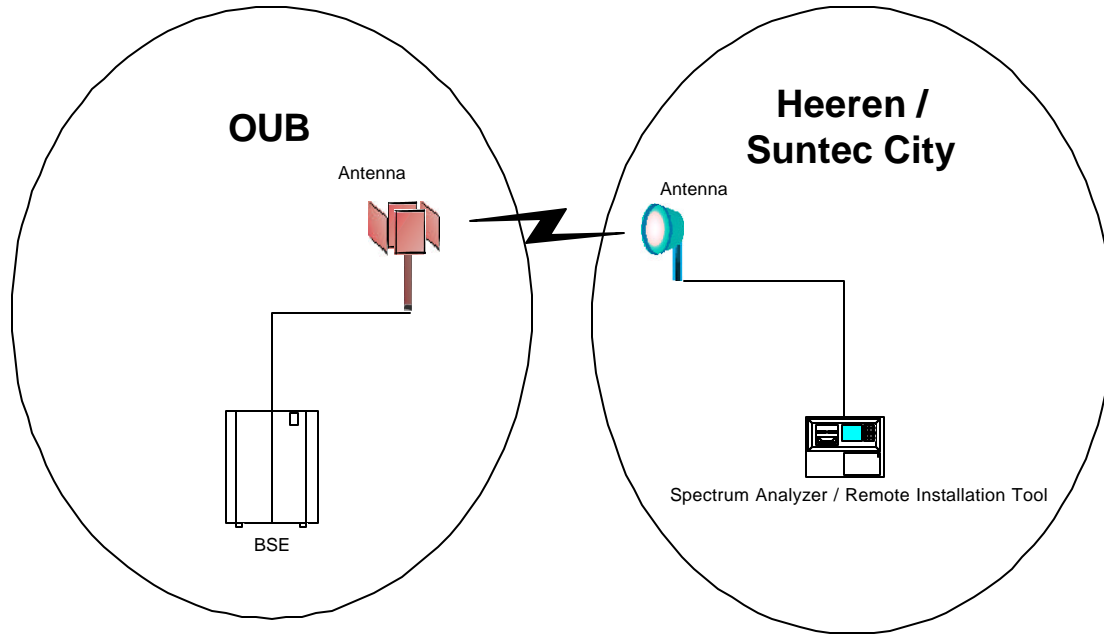

FIGURE 4.4

4.4.1.3. Test Result

The antennas were aligned successfully.

Site	Receive Power Level	Remark
Suntec City	-45dbm	The sensitivity of the LMDS equipment was around -86dbm. Hence, a buffer of 41dbm was obtained. This value was greater than standard buffer requirement of 32dbm
Heeren	-52dbm	A buffer of 33dbm was obtained. This was within the required buffer standard of 32dbm

4.4.2. Remote Station Equipment (RSE) Installation

4.4.2.1. Objective

To configure the RSE and verified that it had been successfully connected.

4.4.2.2. Test Description

- Ensured that the serial number of the RSE was entered into the NMS.
- No additional configuration at the RSE end. Examine whether the NMS would be able to detect the wireless ATM link between the BSE and RSE once it was turned on.

4.4.2.3. Test Results

The RSE was successfully detected by the NMS.

5 Network Management System (NMS) Tests for CBD Trial

Network Management System (NMS) is an essential component of the LMDS system. All components of the LMDS systems can be configured and monitored locally or remotely.

5.1 System Set-up Test

5.1.1. Objective

To examine whether all the modules could be detected with the Network Management Systems.

5.1.2. Test Procedure

- Assumed that all the remote antennas had been aligned correctly.
- Inserted all the necessary modules into the BSE.
- Examined the state of each component using the NMS.
- Entered the configuration parameters for the Antennas.
- Examined the state of each component using the NMS.
- Entered the configurations of the each RSE into the NMS.
- Examined the state of each component using the NMS.
- Removed and re-inserted the radio card into the systems.
- Examined the state of each component using the NMS

5.1.3. Test result

Action	Observation	Successful reboot
Inserted Modules	All modules showed healthy state. Critical Alarm observed for both the base station and antenna.	Yes
Input antenna parameter	The Alarm for the radio disappeared	Yes
Input RSE's	Successful creation of new RSE	Yes

configuration	as shown in the RSE list of the software. Observed Healthy state of each RSE.	
Removed and re-inserted the radio card	Critical event alarm was observed once the card was removed. The alarm list disappeared after the card was re-inserted back to the BSE and rebooted successfully.	Yes

5.2 Connection Set-up Test

5.2.1 Objective

To evaluate ATM, Ethernet and E1 connection set-up with the NMS.

5.2.2 Test Procedure

- One PVC connection to each Ethernet Port of every RSE was established with the NMS.
- An unstructured E1 (G.703) link to the first E1 port of the RSE was created using the NMS.
- A structured E1 (G.704) link with 10 x 64k time slots to the second E1 port of the RSE was created with the NMS.
- The state of each connection was evaluated.

5.2.3 Test Result.

The test was conducted as planned. The Ethernet, unstructured E1 and structured E1 connections were created successfully using the NMS. No alarm event was indicated in the NMS.

The performance of both the Ethernet and E1 connection would be tested in greater detail in Chapter 6 later.

6 LMDS Network Test for the CBD Trial

The main concern of LMDS deployment in Singapore has always been the rain effect on the “Quality of Service”. In the US and Europe, a substantial number of trials had been conducted and the issue of “quality of service” had been addressed thoroughly. However, Singapore may be the first country in the rain region P where such wireless technology had been put under such detail investigation.

The two remote stations (The Heeren and Suntec City) were chosen because of their strategic locations and distance from the base station. The maximum theoretical distance between the base station and remote station is slightly more than 1km, assuming the 28GHz frequency range was used for the LMDS system in Singapore. With the current distances of 1.6km and 2.4km respectively, PI had deliberately challenged the theoretical limit. The findings would be valuable to PI in its cell planning process during the actual deployment stage. Two major network tests were conducted to evaluate the performance of the LMDS. They were the Primary Rate Circuit Emulation test and Ethernet Throughput Test.

6.1 Primary Rate Circuit Emulation Test

6.1.1. Objective

- To verify the ability of the wireless ATM link to carry end-user applications on the primary rate (E1) port of the Remote Station equipment (RSE).
- To evaluate the Bit Error Rate (BER) of the LMDS in all weather condition, with two separate E1 links to Heeren and Suntec City respectively.

6.1.2. Test Procedure

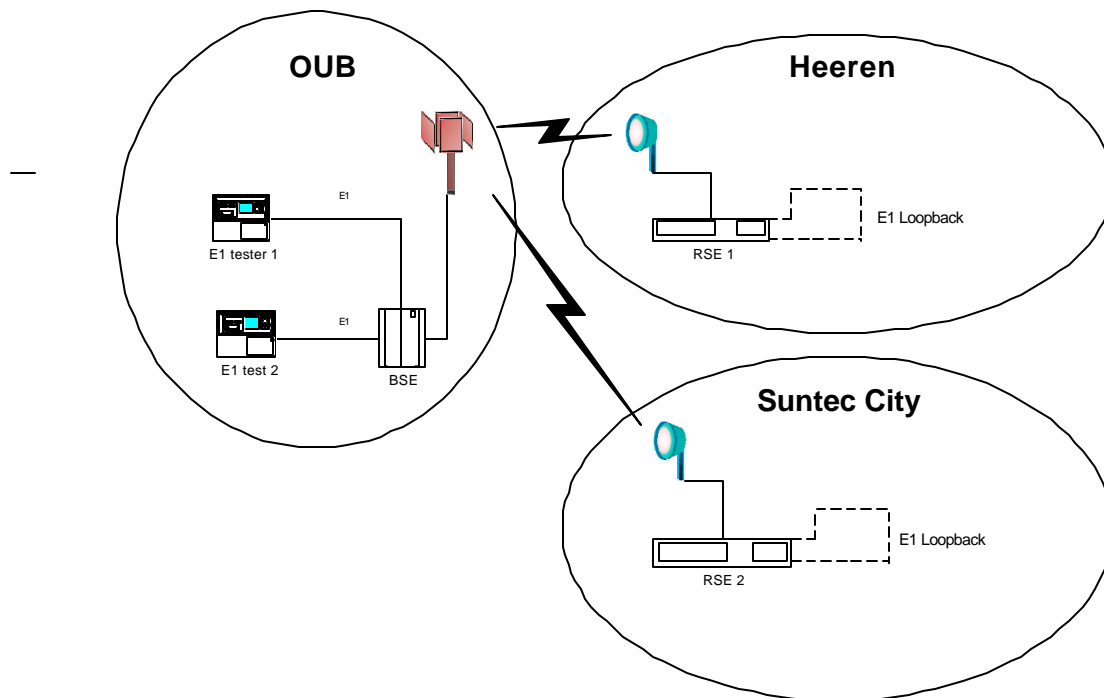

FIGURE 6.1

- Refer to Figure 6.1. Two E1 Testers were connected directly to two of the free E1 ports of the LMDS Base station Equipment (BSE).

- E1 cross-connections between the BSE and the designated E1 ports of the RSEs at the Heeren and Suntec City were created using the Network management system (NMS).
- Loopback circuits were made at the E1 ports of both RSEs.
- The E1 testers would inject full E1 traffic to the LMDS for an extended period of time. The BER result was collated and evaluated.

6.1.3. Test Result

6.1.3.1. Location 1: Suntec City

Distance to Base station: 1.6km

Date	BER*	Availability	RainFall Density (mm/hr)**
15/6/00 - 16/6/00	0	100%	3.5
7/7/00 - 10/7/00	0	100%	9.125
22/7/00 - 26/7/00	7.06e-11	99.9997%	26.56
28/7/00 - 7/8/00	4.53e-8	99.99%	67.87

6.1.3.2. Location 2: The Heeren

Distance to Base station: 2.4km

Date	BER*	Availability*	RainFall Density (mm/hr)**
15/6/00 - 16/6/00	0	100%	3.5
26/6/00 - 27/6/00	0	100%	0
22/7/00 - 26/7/00	7.35e-7	99.99%	26.56
27/7/00 - 7/8/00	5.48e-5	99.86%	67.87

* BER and Availability time are calculated based on one-way radio link statistics

** RainFall Density Statistic from Meteorological Service Singapore

The BER result verified a few main points

- (a) On clear weather condition, both Suntec City and The Heeren demonstrated excellent BER result.
- (b) On heavy rain condition (e.g. between 22/7/00 – 26/7/00), the BER for both sites increased. The E1 test in The Heeren exhibited poorer BER result due to its greater distance from the base station.
- (c) The BER increased as the rainfall density increased. This was clearly illustrated in the result obtained from both sites.

6.2 Ethernet Service Test (BSE to RSE)

6.2.1. Objective

- To verify the serviceability of the Ethernet Connection between BSE to RSE.
- Continuity / Availability and Throughput were the main items evaluated in this test.

6.2.2. Test Procedure

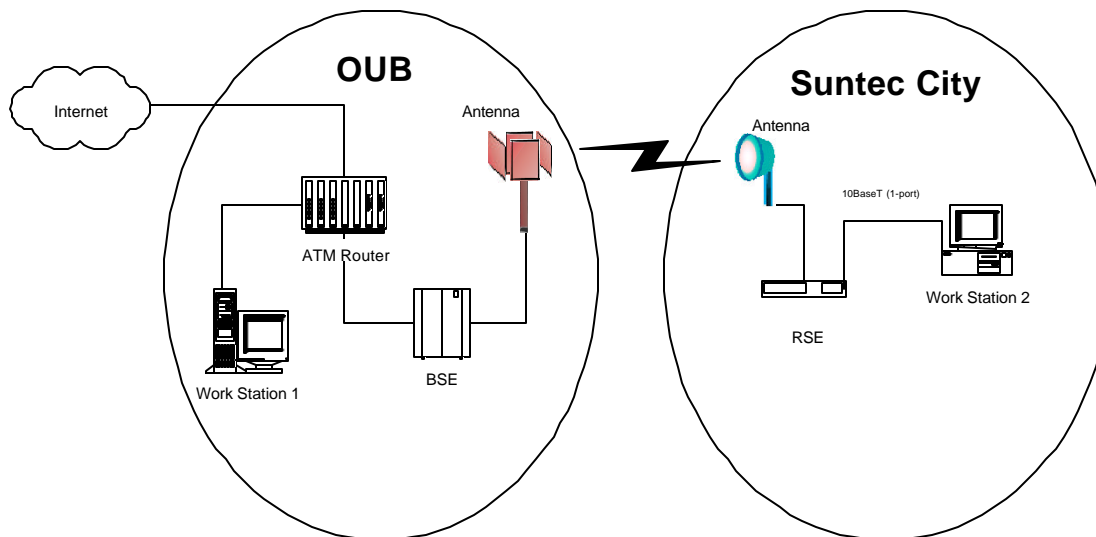

FIGURE 6.2

- Refer to Figure 6.2 above, A Permanent Virtual Circuit (PVC) was created between the ATM router and one of the 10BaseT Ethernet port on the remote station box.
- The data transfer throughput was measured.
- The following bandwidth was allocated for this PVC:
 - Uplink (from remote station to Base station): 3Mbps
 - Downlink (from Base station to Remote station): No threshold

The system connectivity was verified using a continuous “ping” process.

6.2.3. Test Result

6.2.3.1. From Base station to Remote Station

Traffic (Mbps)	TCP Packet Length (kb)	Received buffer length (kb)	Throughput (Mbps)
134.22	65.5	8.2	5.604
1,064.96	520.0	1,024.0	5.874
1,048.58	1,024.0	1024.0	5.694
2,097.15	1,024.0	1024.0	5.635

- The test was completed successfully. The result above showed that the maximum throughput obtained was around 6Mbps.
- The maximum throughput value was constraint by the TCP settings of both workstation 1 and workstation 2, such as the TCP packet length and the received buffer length.

6.2.3.2. From Remote station to Base Station

Traffic (Mbps)	TCP Packet Length (kb)	Received buffer length (kb)	Throughput (Mbps)
8.389	8.2	8.2	2.834
134.22	65.5	8.2	2.986
1,064.96	520.0	1,024.0	2.989
1,048.58	1,024.0	520.0	2.922

The test was completed successfully. The Ethernet throughput was less than the previous test because of the uplink bandwidth constraint of 3Mbps.

6.3 Ethernet Service Test (RSE 1 to RSE 2)

6.3.1. Objective

- To verify the serviceability of the Ethernet Connection between two remote stations located in different sectors.
- Continuity / Availability and Throughput were the main items evaluated in this test.

6.3.2. Test Procedure

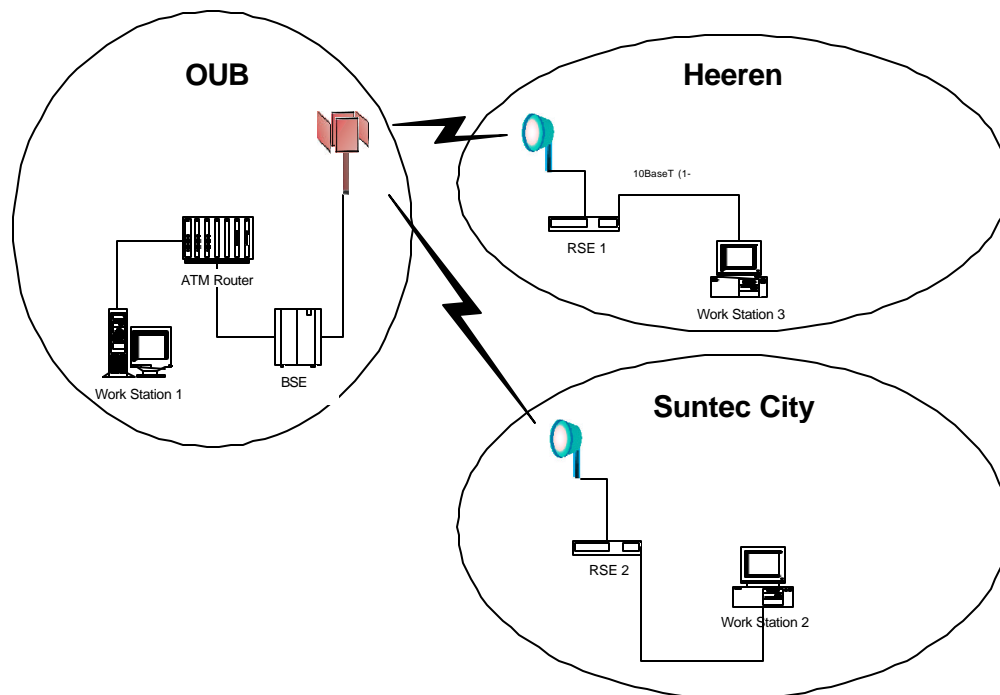

FIGURE 6.3

- Refer to Figure 6.3 above, Two Permanent Virtual Circuits (PVC) were created between the ATM router and the 10BaseT Ethernet port on the remote station box located at Heeren and Suntec City respectively.
- The data transfer throughput was measured.
-

- The following bandwidth was allocated for these two PVCs:
Uplink (from remote station to Base station): 3Mbps
Downlink (from Base station to Remote station): No threshold

6.3.3. Test Result

6.3.3.1. From Work Station 2 to Work Station 3

Traffic (Mbps)	TCP Packet Length (kb)	Received buffer length (kb)	Throughput (Mbps)
8.389	8.2	8.2	2.796
67.11	65.5	65.5	2.851
532.48	520.0	520	2.877
1048.58	1024.0	1024.0	2.853

- The result above showed that the maximum throughput obtained was around 2.8Mbps.
- The throughput is less than section 1 because of the bandwidth limitation set for the uplink traffic

6.3.3.2. From Work Station 3 to Base Station 2

Traffic (Mbps)	TCP Packet Length (kb)	Received buffer length (kb)	Throughput (Mbps)
8.389	8.2	8.2	2.750
67.11	65.5	65.5	2.873
532.48	520.0	520	2.872
1048.58	1024.0	1024.0	2.853

The test was completed successfully. The Ethernet throughput result was similar to the result from test 6.3.3.1.

6.4 Simultaneous E1 and 10BT connection

6.4.1. Objective

To ensure no degradation of service level when both circuit-switched and data traffic are sent through the LMDS system simultaneously.

6.4.2. Test procedure

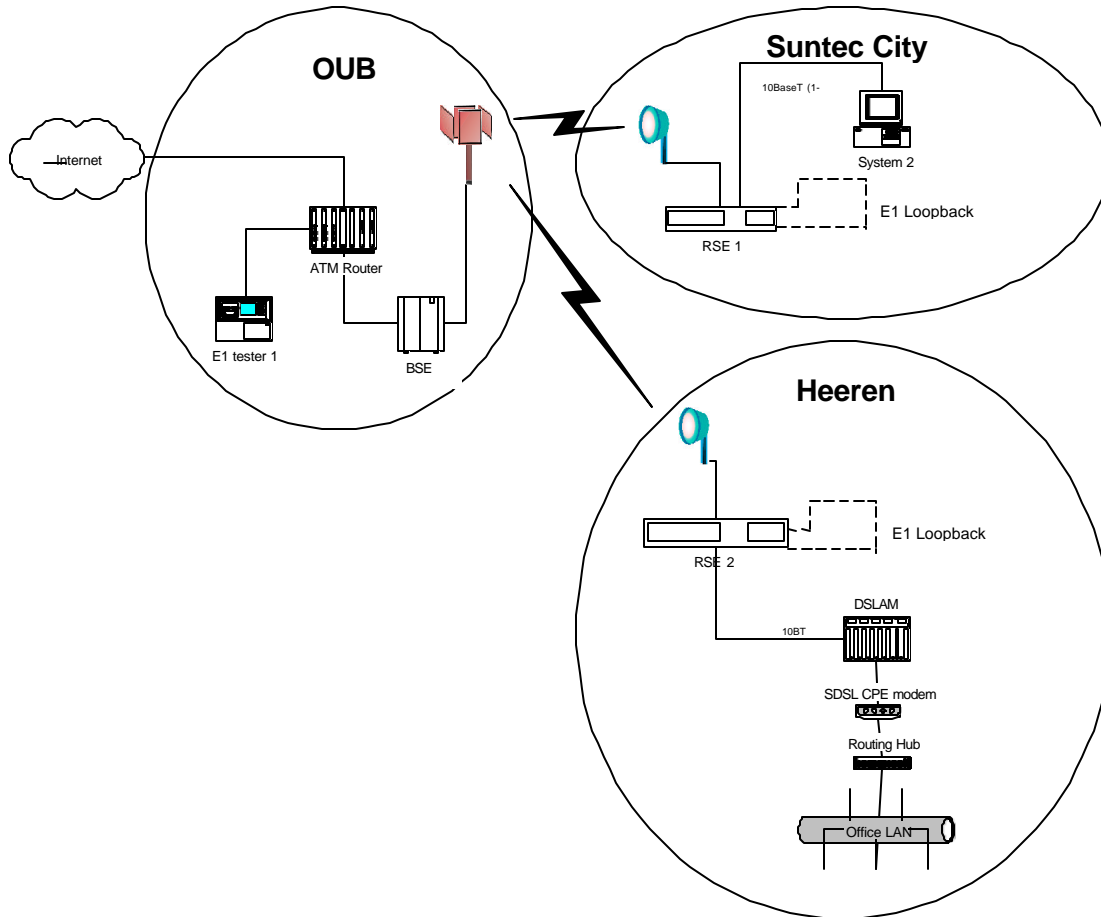

FIGURE 6.4

- Figure 6.4 above showed the network configuration of this test.
- Two E1 testers transmitted full E1 traffic to the Remote Station Equipment (RSE) at Suntec City and The Heeren respectively.
- Ethernet Throughput test (as explained in section 6.2.2) was conducted at the same time.

6.4.3. Test Result

6.4.3.1. BER Result

Date	BER	Availability	RainFall (mm/hr)
15/7/00 – 22/7/00	0	100%	0

6.4.3.2. Ethernet Throughput Result

Traffic (Mbps)	TCP Packet Length (kb)	Received buffer length (kb)	Transfer Time (s)	Throughput (Mbps)
1,048.58	1,024.0	520.0	175.54	5.973
2,097.15	1,024.0	520.0	353.13	5.938

The result showed no degradation of services with simultaneous E1 and Ethernet traffic over the LMDS system.

7 Application test for CBD Trial

The network tests listed in the previous chapter were run to validate the performance and reliability of the LMDS network. In this chapter, a number of application tests were conducted to verify the ability of the LMDS Systems to support these popular narrowband and broadband applications.

7.1 Basic Internet application test

7.1.1. Objective

To evaluate the ability of the LMDS to support the basic Internet applications, such as Internet surfing, emailing and ftp.

7.1.2. Test Procedure

- Refer to Figure 7.1 below, the LMDS was connected to the public Internet via an ATM link between the Base Station Equipment (BSE) at OUB and PI's network.
- Applications such as email, Internet surfing and ftp were run on both workstation 2 and workstation 3. These machines were connected directly to the Ethernet Port of the Remote Station Equipment (RSE).
- Email was downloaded from the PI's public email server.
- <http://www.pacfusion.com> and <http://www.cnn.com> were accessed to verify the success of Internet Surfing.
- A 3MB file was downloaded from an internal ftp server located within the PI.

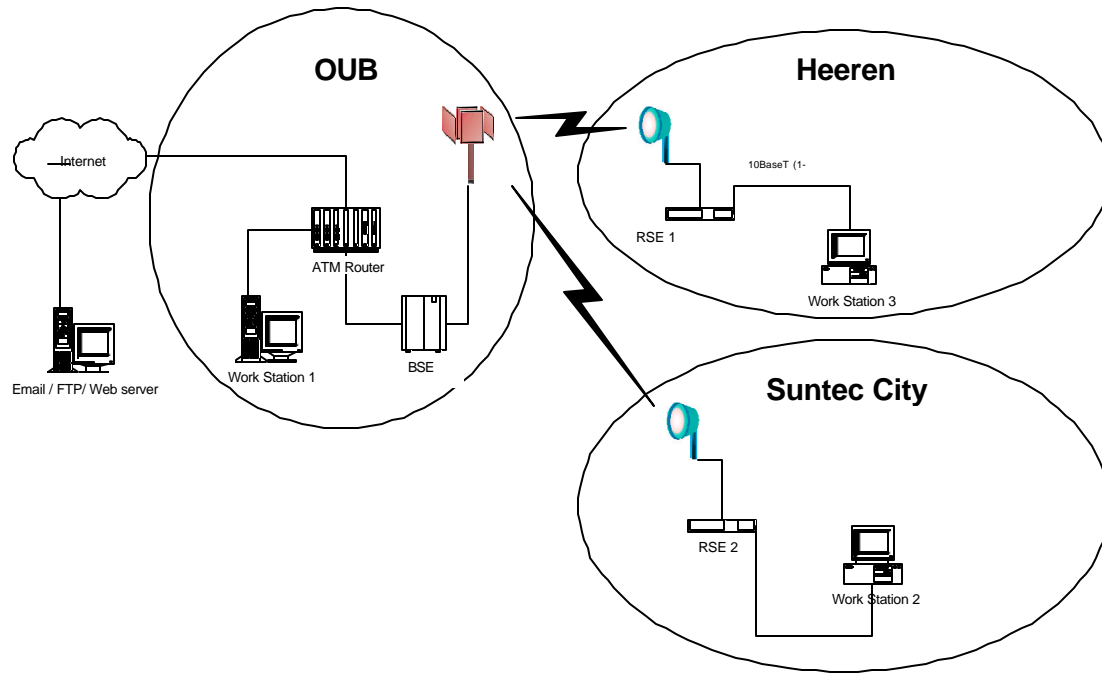

FIGURE 7.1

7.1.3. Test Result

The tests were completed successfully as per above configuration.

File Size (Mb)	Transfer Time (s)	Throughput (Mbps)
32	5.9	5.42
44	8.2	5.37

7.2 Video streaming test

7.2.1. Objective

To verify the LMDS's capability in supporting the Video streaming application.

7.2.2. Test Procedure

- A Pentium II 300MHz PC was connected to the Ethernet port of the RSE at The Heeren.
- The PC was loaded with the QuickTime G4 software.
- An overseas video streaming site <http://www.apple.com/trailer> was accessed. A Full screen version of the video clips was chosen to test this video streaming capability via LMDS.

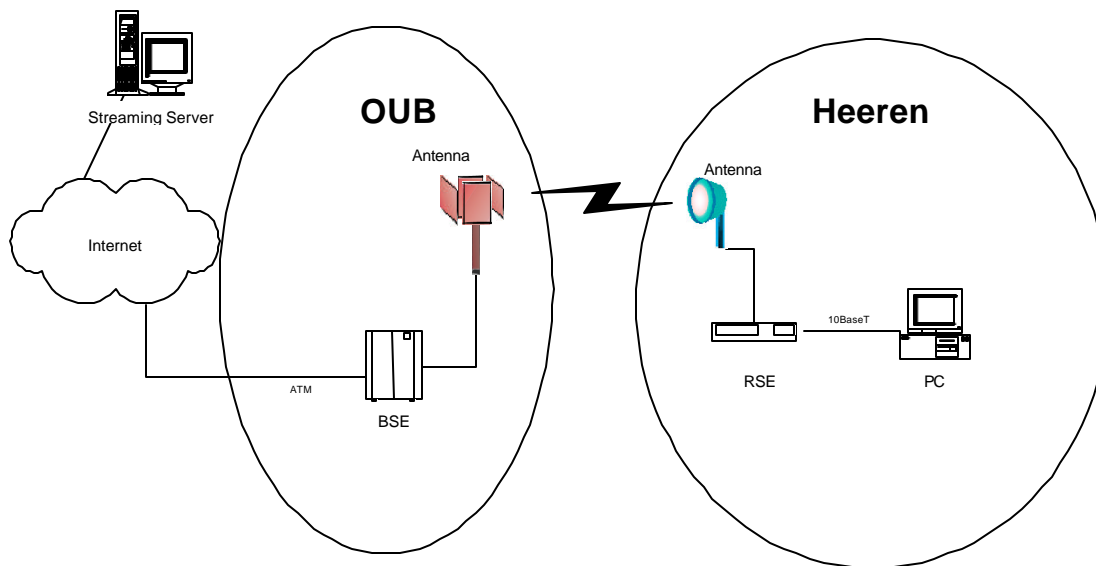

Figure 7.2

7.2.3. Test Result

The tests were completed successfully as per above configuration. The 3-minute full screen video streaming of the trailer was received successfully with smooth images and sounds.

7.3 Video conferencing Test

7.3.1. Objective

To verify the LMDS's capability in supporting the Video conferencing application.

7.3.2. Test Procedure

- Two PCs with Prolink Video Cameras were configured based on Figure 7.3 below.
- PC1 was connected to the PI's Intranet whereas PC2 was linked to the RSE at The Heeren.
- The standard video conferencing software, "Microsoft NetMeeting" was used to test this application.
- Both PCs would run the "NetMeeting" software. PC1 would initiate a call to PC2. Once PC2 accepted the call, both parties would start exchanging audio and visual images.

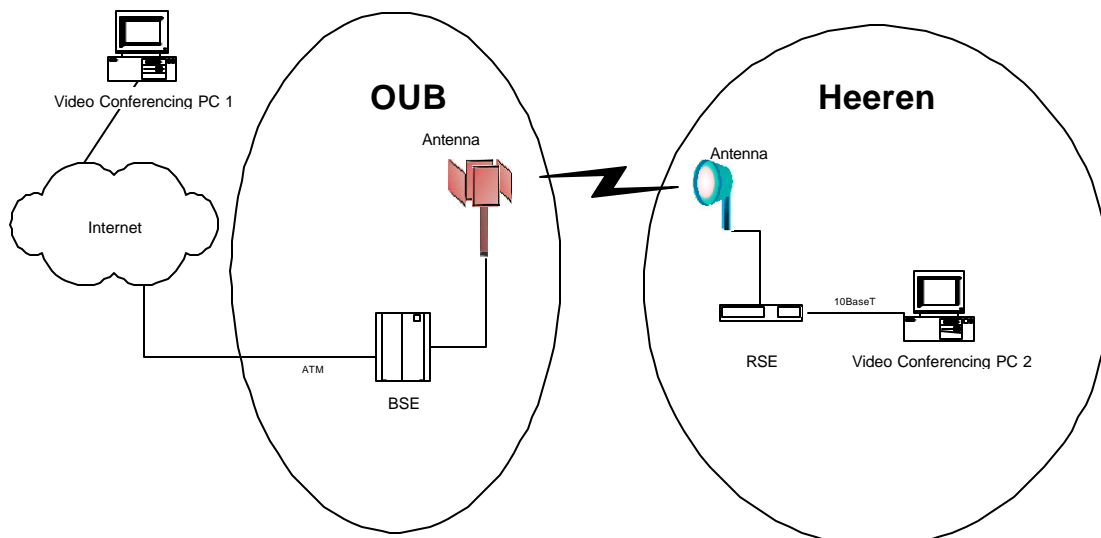

FIGURE 7.3

7.3.3. Test Result

The tests were completed successfully as per above configuration. Each party would be able to see and hear the opposite party clearly with this standard video conferencing software.

7.4 Symmetrical Digital Subscriber Line (SDSL) Test

7.4.1. Objective

To evaluate LMDS's capability to support Broadband access medium such as Digital Subscriber Line (DSL).

7.4.2. Test Procedures

- A DSL Access Multiplexer (DSLAM) was installed at Remote station as shown in Figure 7.4 below.
- This DSLAM was capable to support multiple customers who required broadband access. We had provided a free trial to one of the customers in The Heeren using LMDS and Symmetrical Digital Subscriber Line (SDSL) technology.
- A DSL modem would be placed at the customer end to terminate the DSL traffic.
- As the customer was currently running a private IP network, a router was needed in between the DSL modem and the customer's Internet Hub, to map all the private IP addresses to public IP addresses.
- Basic Internet Access test was conducted at the customer end to verify the functionality of the network.

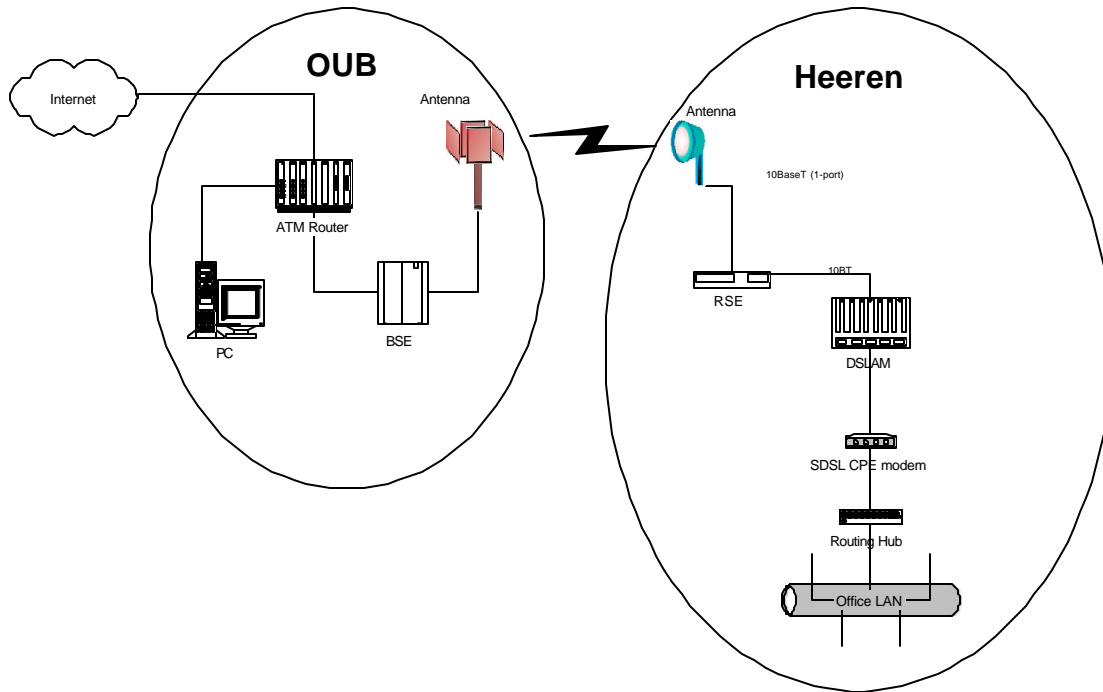

FIGURE 7.4

7.4.3. Test Result

The following result illustrated that LMDS was able to support DSL as the last-mile broadband access medium.

Test conducted	Result
Continuous "ping" to www.yahoo.com for 5 minute	Zero loss packet.
Access www.cnn.com	Full page response within 3 seconds (without proxy)

7.5 Broadband Remote Access Service (RAS) test

7.5.1. Objective

Remote access service (RAS) allows any users to authenticate with an ISP using a given username and password and subsequently to log into the ISP's network for Internet access purpose. However, currently the RAS is mainly applicable to standard dial up access with a maximum speed of 56kbps.

Broadband RAS is a technology where the similar authentication processes is required for Broadband Internet access. Point-to-Point Protocol over Ethernet (PPPoE) is one of the popular standards for Broadband RAS. Identity verification is required for any user who is physically connected to a LAN before a valid IP address is assigned to him/her PCs.

7.5.2. Test Procedure

- Refer to figure 7.5, a PC running the PPPoE client was connected directly to the Ethernet port of the RSE.
- The PPPoE client would initiate the authentication process with the Broadband RAS equipment located at OUB.
- The Broadband RAS equipment would then verify the user identity with the assigned Radius server.
- Once the identity of the user was validated, a valid IP address would be assigned to the PC for Internet access purpose.

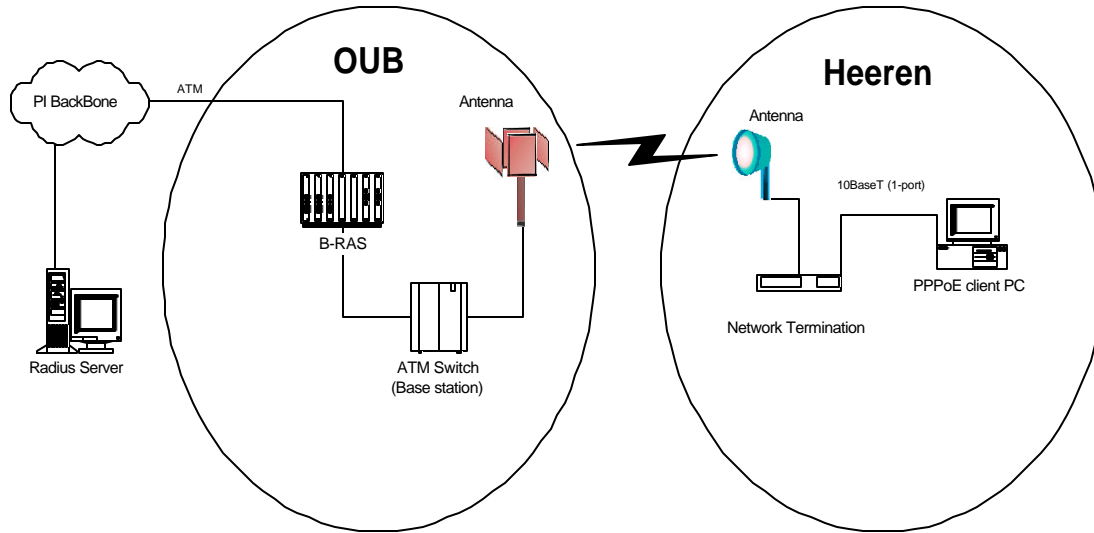

Figure 7.5

7.5.3. Test Result

The test was completed successfully as per above configuration. The PPPoE client completed the authentication process successfully with the Broadband RAS equipment via LMDS. A valid IP was subsequently assigned to PC. The successful “ping” test and “Internet Surfing” test illustrated the healthy state of the Ethernet connection established using the B-RAS feature.

7.6 Fractional E1 tests (Loopback)

7.6.1. Objective

To verify that the Nx64k lease line traffic can be carried over the LMDS successfully.

7.6.2. Test Procedure

- The test network was set-up as shown in figure 7.6 below.
- A lease line circuit with 10x64k time slots was created between the BSE and the E1 port of the RSE at The Heeren.
- A loopback circuit was set at the E1 port of the RSE.
- The E1 tester was configured to transmit a train of 10x64k timeslots traffic.
- With the loopback circuit created at the RSE, the tester would be able to obtain an accurate Bit Error Rate (BER) result for to verify the functionality of the fractional E1 lines with LMDS as the transport medium.

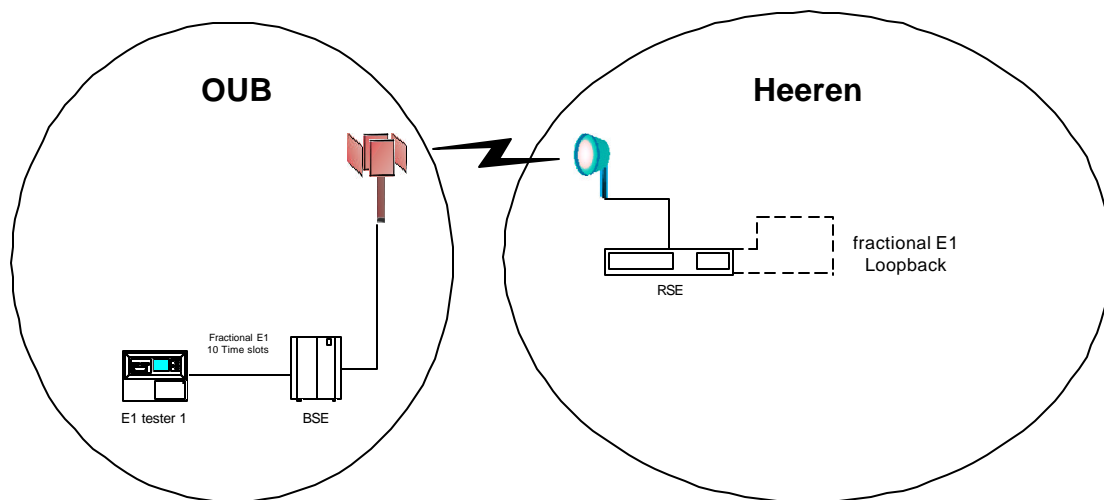

FIGURE 7.6

7.6.3. Test result

The test was completed successfully as per above configuration.

Test period	BER	Availability
15 minutes	0	100%

The BER=0 result verified the capability of the LMDS systems to carry fractional E1 traffic over the wireless ATM medium.

7.7 Voice Test

7.7.1. Objective

To verify that Plain Old Telephone Services (POTS) services can be carried over the LMDS.

7.7.2. Test Procedure

- Figure 7.7 illustrated the network diagram for this test.
- A 64k voice circuit was created at the BSE.
- Two multiplexers were connected at the two ends of the LMDS.
- One multiplexer had a voice card with FXO interface. This interface would be used to terminate the voice circuit at the PSTN.
- The second multiplexer was connected directly to the E1 port of the RSE at The Heeren. A voice card with FXS interface was installed in this multiplexer. This enabled a normal telephone to be connected directly to the multiplexer.
- Phone calls were made from this telephone to a telephone number in PI office and a Singtel's handphone number.

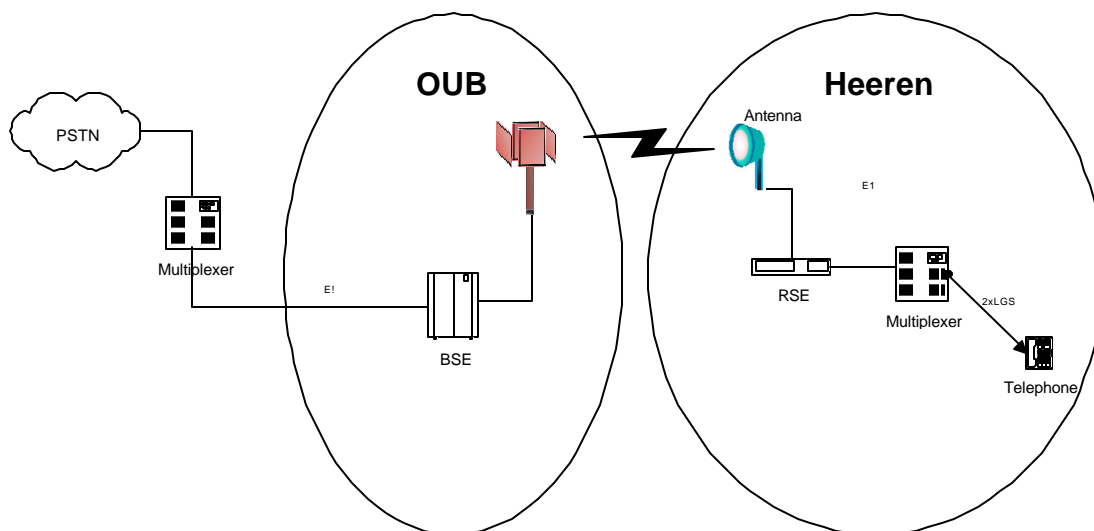

FIGURE 7.7

7.7.3. Test result

The voice circuit was commissioned successfully. Calls were made to both the SingTel's handphone number and a fixed line number. The voice quality was very clear and no echo or interference was observed during the conversation.

8 Pacific Internet's LMDS Trial at Science Park Area

8.1 Trial Location

Two buildings in Science Park, namely Cintech III and Rutherford, had been chosen as the base station and remote station site respectively for PI's LMDS trial. One 90-degree sectorial antenna was installed at the rooftop at Cintech III. Two remote station antennas were installed at Rutherford building. The objective of installing two antennas on the same building was to simulate two separate remote stations within the same coverage sector. The two remote stations were approximately 10 meter apart.

Table 8.1 showed the detail information of the three sites covered in this trial.

Site Name	Cintech III	Rutherford 1	Rutherford 2
Function	Base Station	Remote Station	Remote Station
Address	79, Science Park Drive, Singapore 118256	89, Science Park Drive, Singapore 118261	89, Science Park Drive, Singapore 118261
Latitude	N 01'17'310	N 01'17'369	N 01'17'369
Longitude	E 103'47'506	E 103'47'483	E 103'47'483
Estimated Distance from Base station (m)	0	140	142

TABLE 8.1

8.2 *Trial set-up*

One sectorial antenna was installed on the rooftop of the base station located at Cintech III.

Two remote stations at Rutherford building were chosen for their clear Line of Sight (LOS) and short distance to the base station. Both remote stations were within the coverage area of same sector.

9 LMDS Commissioning for the Science Park Trial

9.1 Overall Network Set-up

Figure 9.1 below illustrated the overall network set-up for the trial conducted in the Science Park area. The detail of the each test would be further described in chapter 10 later.

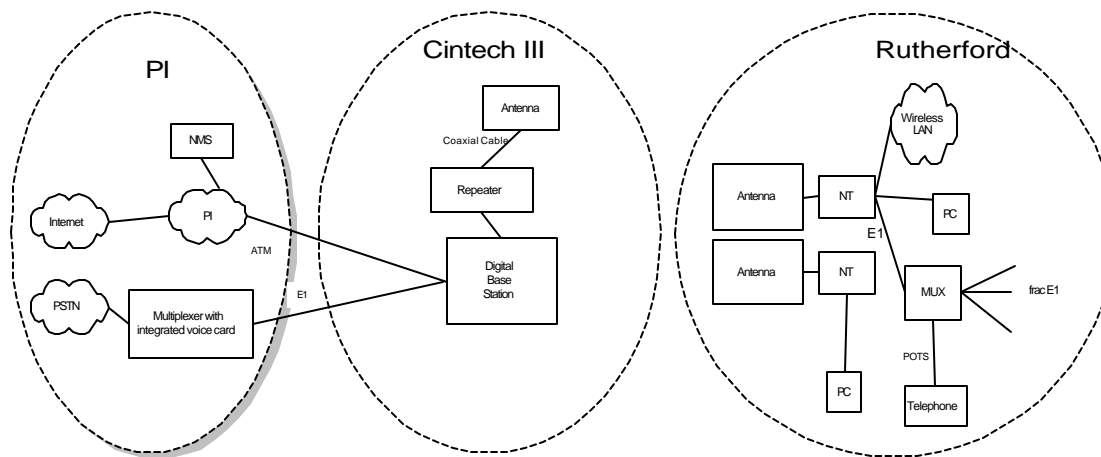

FIGURE 9.1

9.2 Frequency Allocation

9.2.1. Base Station (BS) Configuration Parameters

	Sector 1
Direction	To Rutherford Building
Sectorial Antenna Type	90 degrees
Downlink RF Start (GHz)	28.0
Downlink RF End (GHz)	28.036
Uplink RF Start (GHz)	27.5
Uplink RF End (GHz)	27.518

9.2.2. Remote Station (RS) Configuration

	Remote Station 1	The Remote Station 2
No. of Transceiver Antennas	1	1
Distance to BS (m)	140	142

9.3 Base Station Commissioning

9.3.1. Installation verification

9.3.1.1. Objectives

To verify that the equipment had been fully installed as per the instructions contained in the LMDS equipment Installation manual.

9.3.1.2. Test Procedure

- The installation procedure stated in the Wireless Commissioning Plan was reviewed.
- Some of the major tasks included antenna azimuth and elevation verification and adjustments, grounding, lightning protection and cable type confirmation.

9.3.1.3. Test Result

Installation was completed as per documentation

9.3.2. BTS IF Cables System Loss Calibration

9.3.2.1. Objective

The purpose of system loss calibration was to measure the fixed decibel loss in both the downstream and upstream directions. This test determined the additional attenuation needed to be added at the combiner/splitter. The total fixed decibel loss must be 27 ± 1 dB @ 2050 MHz for downstream and 24 ± 1 dB @ 900 MHz upstream directions.

9.3.2.2. Test Procedure

- Using the loss measured during the Intermediate Frequency (IF) cable sweeps, installed any required pads to achieve the appropriate attenuation in the downlink and uplink Base Station IF paths.
- The result of the cable sweep test was recorded.

9.3.2.3. Test Results

Base Station (BS) – Sector 1					
Cable No.	Label	Approx. Length (m)	Freq (MHz)	Insertion Loss (dB)	Attenuator value added (dB)
1	Downlink	150	2050	-24.17	-3
2	Uplink	151	900	-19.33	-4

The appropriate attenuator values were determined successfully and subsequently installed at the combiner/ splitters for both the uplink and downlink directions.

9.4 Remote Station Commissioning

The main objective of this test was to verify that the remote station equipment had been fully installed as per the instructions contained in the Remote Station Installation manual.

Some of the main installation items include:

Remote Station Equipment – standard 2U, 19” rack equipment, rack-mounted or wall-mounted

Radio Termination (RT) – To convert the Intermediate Frequency (IF) to Radio Frequency (RF). The RT is normally installed next to the antenna on the rooftop.

Antenna - 20” parabolic antenna installed on the rooftop. Wall-mounted or poll-mounted.

9.4.1. CPE Antenna Alignment

9.4.1.1. Objective

To align every antenna in the trial network for optimal performance.

9.4.1.2. Test Procedure

- The Remote Station antenna alignment was tuned to obtain a –30 dBm receive power level at the Remote Station Equipment (RSE).
- The same procedure was repeated for each remote station site.

9.4.1.3. Test Result

The antennas were aligned successfully to obtain a –30dbm receive power level at each remote station.

9.4.2. Remote Station Equipment (RSE) configuration

9.4.2.1. Objective

To configure the RSE and verified that it had been successfully connected.

9.4.2.2. Test Description

- The RSE was configured with the appropriate frequency parameters.
- The wireless ATM link should then be established and the RSE should enter the network.

9.4.2.3. Test Results

Downstream Frequency Configuration:

CPE Site	RF Rx Start	RF RX Centre	RF Rx End
Rutherford	27850	28018	28350

Upstream Frequency Allocation:

CPE Site	RF Rx Start	RF Rx Centre	RF Rx End
Rutherford	27350	27505	27650

10 Network Management System (NMS) Tests for the Science Park Trial

Network Management System (NMS) is an essential component of the LMDS system. All components of the LMDS systems can be configured and monitored locally or remotely.

10.1 System Set-up Test

10.1.1. Objectives

This chapter focused on the ability of the LMDS network, including the Base Station and remote stations, to be fully managed by a central NMS. An additional element management system was installed and integrated to the central NMS. The purpose of the element management systems was to control all the peripheral equipment such as the multiplexer.

10.1.2. Test Procedure

The following elements would be tested and verified:

- Equipment commissioning using the user-friendly graphical user interface.
- Full management of network nodes and remote station boxes
- Alarms and Trouble Tickets management
- Configuration, Maintenance and Diagnostics of network elements (cards, ports, circuits)

10.1.3. Test Result

Test completed successfully. All the network elements could be managed by the network and element management systems.

11 LMDS Network Test for the Science Park Trial

The two remote stations were chosen because of their strategic locations. In contrary to the CBD trial, the distance between the base station and remote station was around 140 meters. This distance was well within the allowed limit of approximately 1km. Two major network tests were conducted to evaluate the performance of the LMDS in this environment, namely the Primary Rate Circuit Emulation Test and Ethernet Throughput Test.

11.1 Primary Rate Circuit Emulation Test

11.1.1. Objective

- To verify the ability of the wireless ATM link to carry end-user applications on the primary rate (E1) port of the Remote Station equipment (RSE).
- To evaluate the Bit Error Rate (BER) of the LMDS systems in all weather condition.

11.1.2. Test Procedure

- The wireless ATM link would be tested between each BSE and RSE
- The test pattern was generated and injected at the RSE at Cintech III via an unused port on the E1 Circuit Emulation card.
- An ATM PVC path is created between the Circuit Emulation port at the BSE and the E1 port of the RSE.
- Figure 11.1 below illustrated the topology of the test configuration. A software loopback circuit was set at the E1 port on the RSE via the NMS.

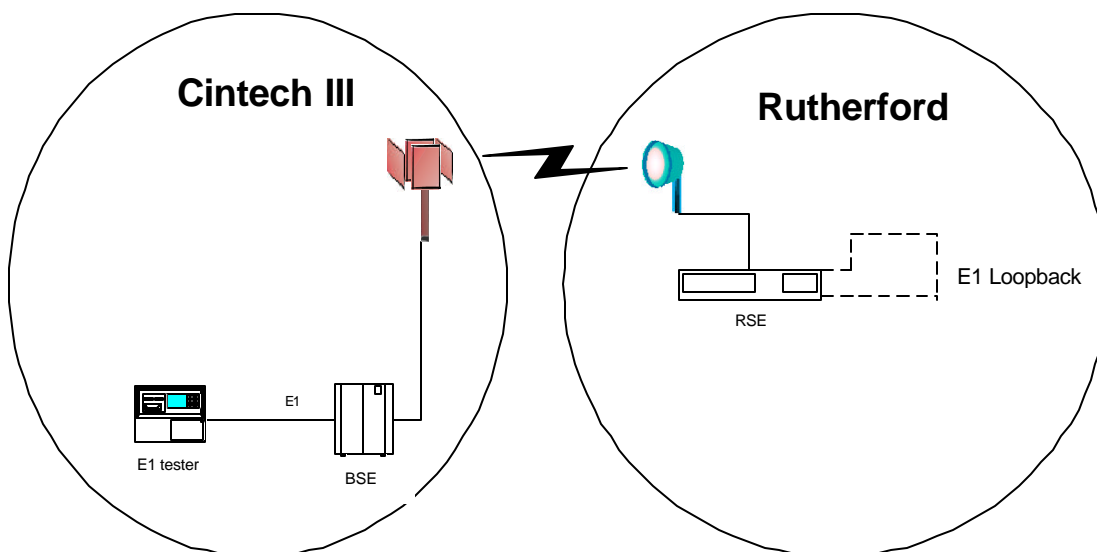

Figure 11.1

11.1.3. Test Results

Location Name: Rutherford 1
Distance to Base station: 140m

Date	BER*	AV	RainFall Density (mm/hr)**
8/6/00 – 9/6/00	0	100%	0
9/6/00 – 12/6/00	0	100%	30.7

* BER and Availability time are calculated based on one-way radio link statistics

** RainFall Density Statistic from Meteorological Service Singapore

BER test was conducted for five days. No error was detected even under heavy rain condition. This excellent result was a result of the short distance between the base station and the remote station.

11.2 Ethernet Service Test

11.2.1. Objective

- To verify the serviceability of the Ethernet Connection between BSE to RSE via LMDS.
- Continuity / Availability and Throughput were the main items evaluated in this test.

11.2.2. Test Procedure

- Refer to Figure 11.2 below. A Permanent Virtual Circuits (PVC) was created between the two Ethernet ports on the RSEs located in the Rutherford building. As the BSE was also an ATM switch, the end-to-end PVC could be created without the need of having additional ATM switch for this test.
- The connection between the PCs is a 4Mbps PVC with UBR service.
- The connectivity of the system was verified with a continuous “ping” process.

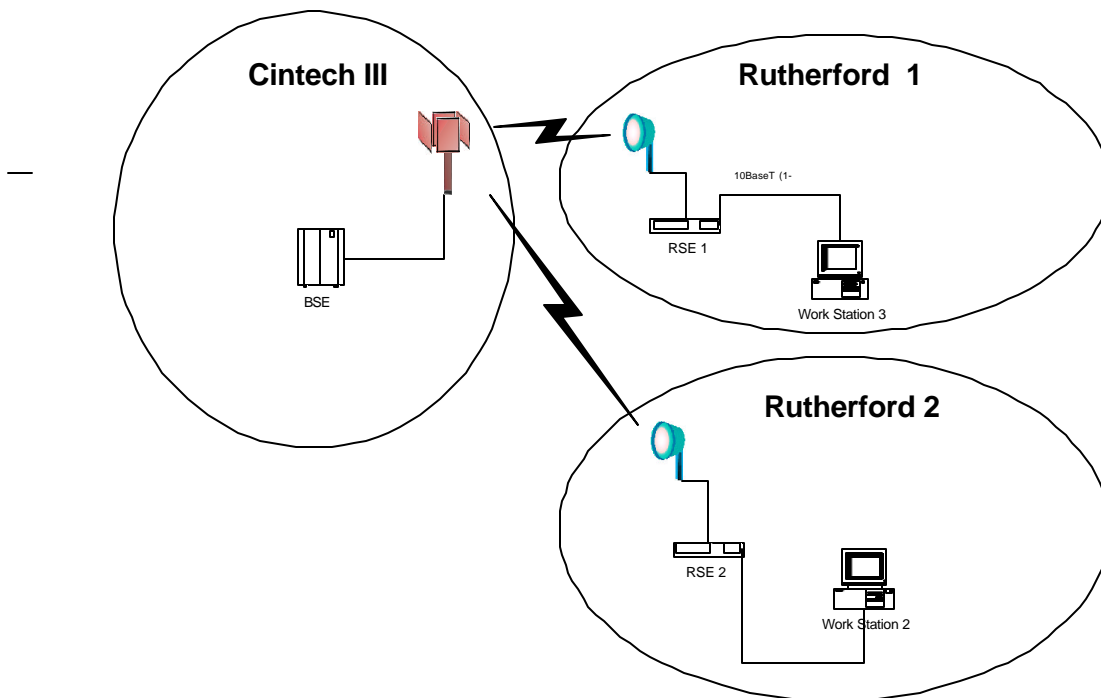

FIGURE 11.2

11.2.3. Test Result

File Size (Mb)	Transfer Time (s)	Throughput (Mbps)
44.2	14.7	3.0
44.2	14.2	3.1

The result above showed that an average throughput of 3Mbps was obtained.

11.3 Fade Margin Test

11.3.1. Objectives

To examine by how much the signal could be degraded before errors were introduced. Unlike the CBD Trial, this test could be conducted on-air because the uplink and downlink paths used separate coaxial cables for propagation.

11.3.2. Test Procedure

- Refer to Figure 11.3. An inline attenuator on the “transmit” Intermediate Frequency (IF) side of the Radio card was inserted at the Base Station.
- Attenuation was increased until the remote station lost the network connectivity. Noted the attenuator setting.
- Attenuator setting was then decreased until the remote station locked back to the network.
- The attenuator setting was again noted.
- The reading on the attenuator was the amount of fade margin for this particular link.

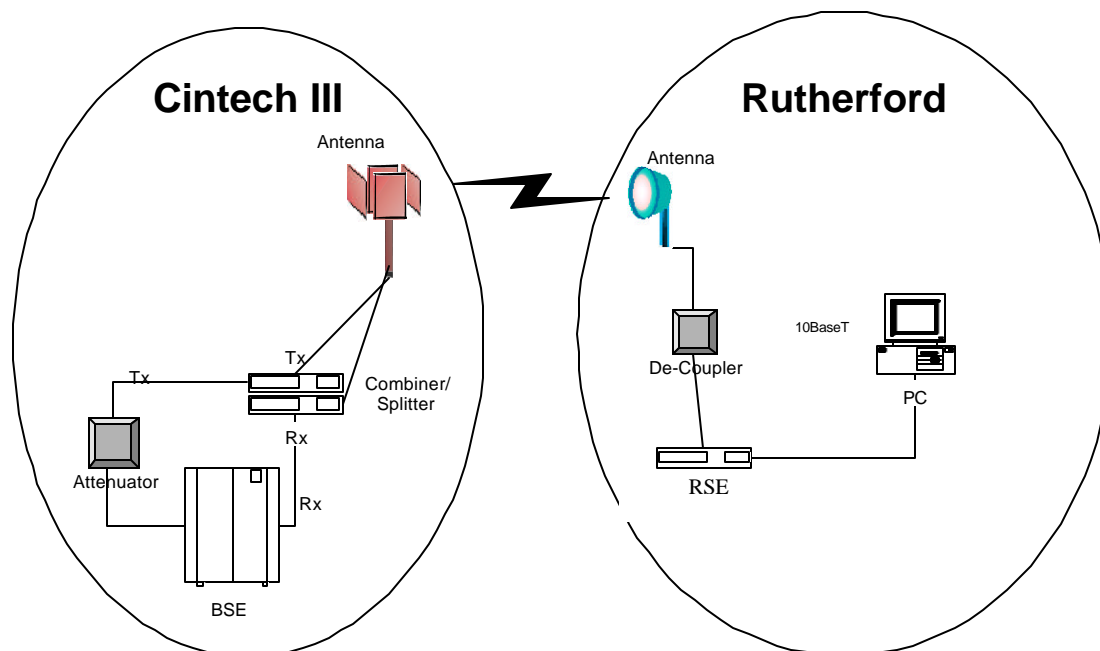

FIGURE 11.3

11.3.3. Test Results

Initial IF Transmit level set at the Radio Card: +4 dBm
Initial Receive level at Remote Station (NT): -12.3dBm
Receive level at remote station after step attenuator was added to the
Transmit IF at Base station: -17.5dBm

Attenuation at Tx IF at BSE	RSE Rx Level (dBm)	RSE Status
0	-17.5	Network entered
10	-27.7	Network entered
20	-37.5	Network entered
25	-42.5	Network entered
30	-46.9	Network entered
40	-56.6	Network entered
41	-58.0	Network entered
42	-59.2	Network entered
43	-60.8	Network lost
44	-61.4	Network lost

The fading margin of the wireless link for the remote station was around 43dBm

11.4 Cross Band Interference

11.4.1. Objectives

To evaluate any possible interference between the upstream and downstream signals. Depending on how the spectrum was split up between upstream and downstream, cross band interference might or might not be an issue. The guard band used was also a factor that would increase or decrease the cross band interference.

11.4.2. Test Procedure

- The spectrum analyser was connected to the coaxial cable which was normally connected to the receive port of the radio card (upstream).
- Checked if there was any downstream signal that can be seen at the edge of the band. If a signal was observed, checked if the antennas were installed with the proper spacing between them.

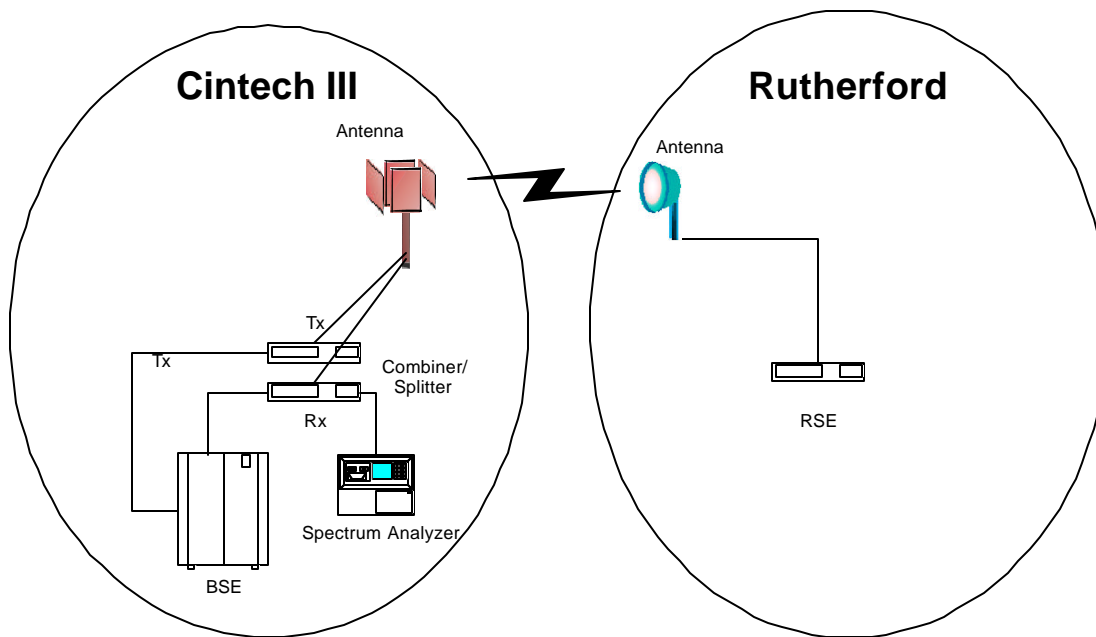

FIGURE 11.4

11.4.3. BTS Test Results

No interference was found during the test.

12 Application test for the Science Park Trial

The network performance tests listed in the previous section were to validate the operation of the LMDS network. A variety of application tests were conducted to verify the ability of the LMDS Systems to support such applications.

12.1 Basic Internet application test

12.1.1. Objective

To evaluate the ability of the LMDS systems to support the basic Internet applications, such as Internet surfing and emailing.

12.1.2. Test Procedure

- Refer to Figure 12.1 below, the LMDS system was connected to the public Internet via an ATM link between the base station located in Cintech III and PI network.
- A PC was connected to the Ethernet Port of the Remote Station Equipment (RSE) in the Rutherford Building.
- Email was downloaded from the PI's public email server.
- <http://www.pacfusion.com> and <http://www.cnn.com> were accessed to verify the success of Internet Surfing.
- A 3MB file was downloaded from an internal ftp server located within the PI.

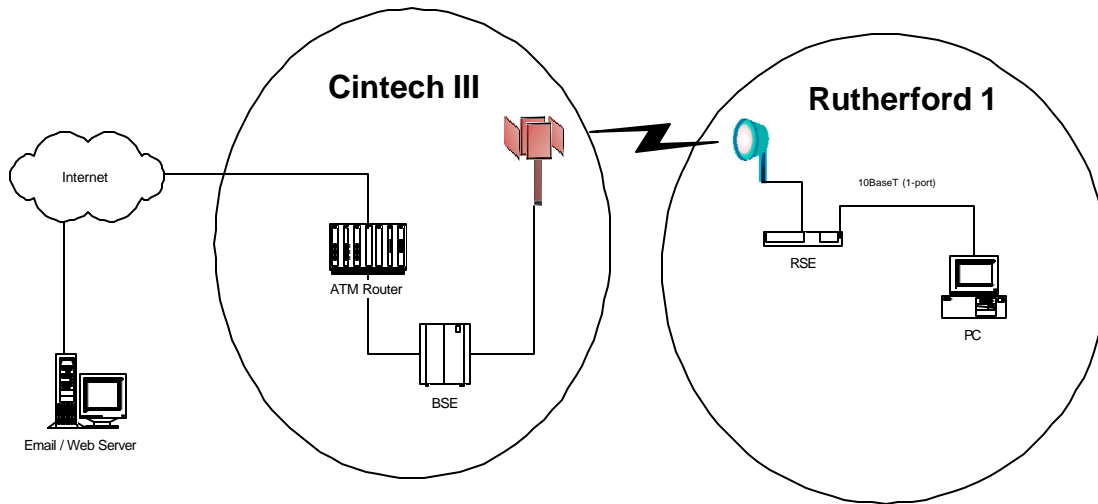

FIGURE 12.1

12.1.3. Test Result

The tests were completed successfully as per above configuration.

12.2 Video streaming test

12.2.1. Objective

To verify the LMDS's capability in supporting the Video streaming application.

12.2.2. Test Procedure

- A PC was connected to the Ethernet port of the RSE.
- The PC was loaded with the QuickTime G4 software.
- An overseas video streaming site <http://www.apple.com/trailer> was accessed. A Full screen version of the video clips was chosen to test this video streaming capability via LMDS.

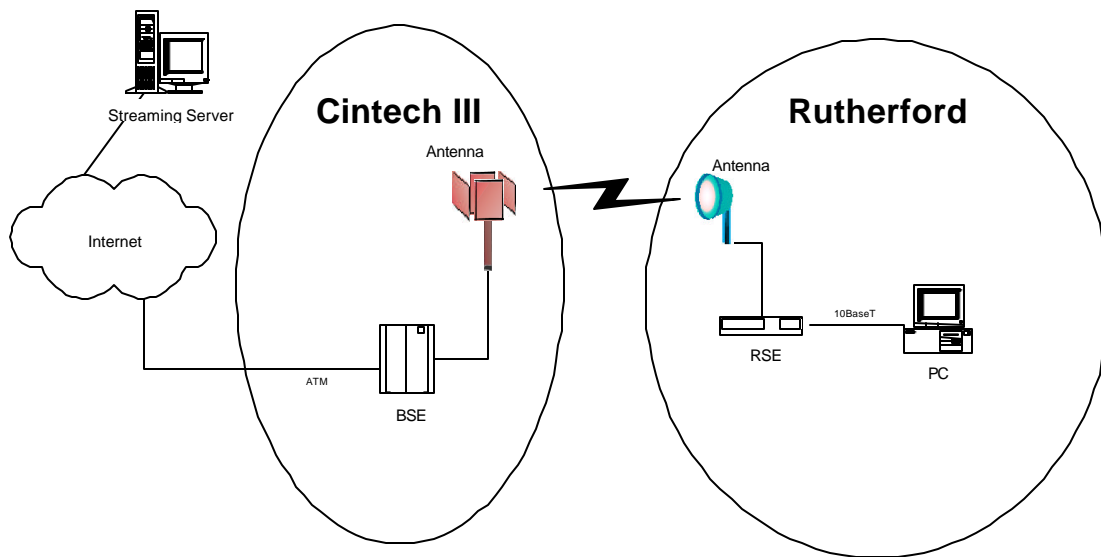

Figure 12.2

12.2.3. Test Result

The tests were completed successfully as per above configuration. The 3-minute full screen video streaming of the movie trailer was received successfully with smooth images and sounds.

12.3 Video conferencing Test

12.3.1. Objective

To verify the LMDS's capability in supporting the Video conferencing application.

12.3.2. Test Procedure

- Two PCs with ProLink Video Cameras were installed based on the configurations as shown in Figure 12.3 below.
- PC1 was connected to the internal network at PI headquarter whereas PC2 was directly connected to the RSE in Rutherford building.
- The standard video conferencing software, "Microsoft NetMeeting" was used to test this application.
- Both PCs would run the "NetMeeting" software. PC1 would initiate a call to PC2. Once PC2 accepted the call, both parties would start exchanging audio and visual images.

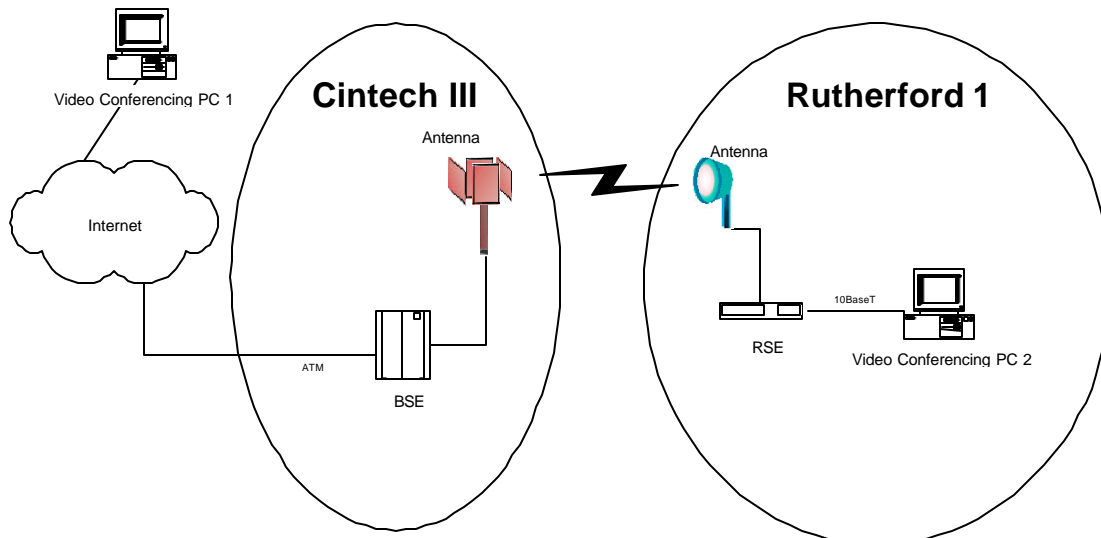

FIGURE 12.3

12.3.3. Test Result

The tests were completed successfully as per above configuration. Each party would be able to see and hear the opposite party clearly with the standard video conferencing software.

12.4 Fractional E1 tests (Loopback)

12.4.1. Test Objectives

To verify that N x 64K lease line traffic could be carried over LMDS successfully.

12.4.2. Test Description

- Test network will be set-up as per Figure 12.4 shown below.
- Nx64K lease line (TDM) data path (V.35 DCC) would be created from one multiplexer to the other end over LMDS.
- A TDM tester would be connected to the V.35 interface of the first multiplexer.
- A loopback was set at the V.35 interface of the second multiplexer.
- The data path would be BERT to confirm the Bit Error Rate was within standard.

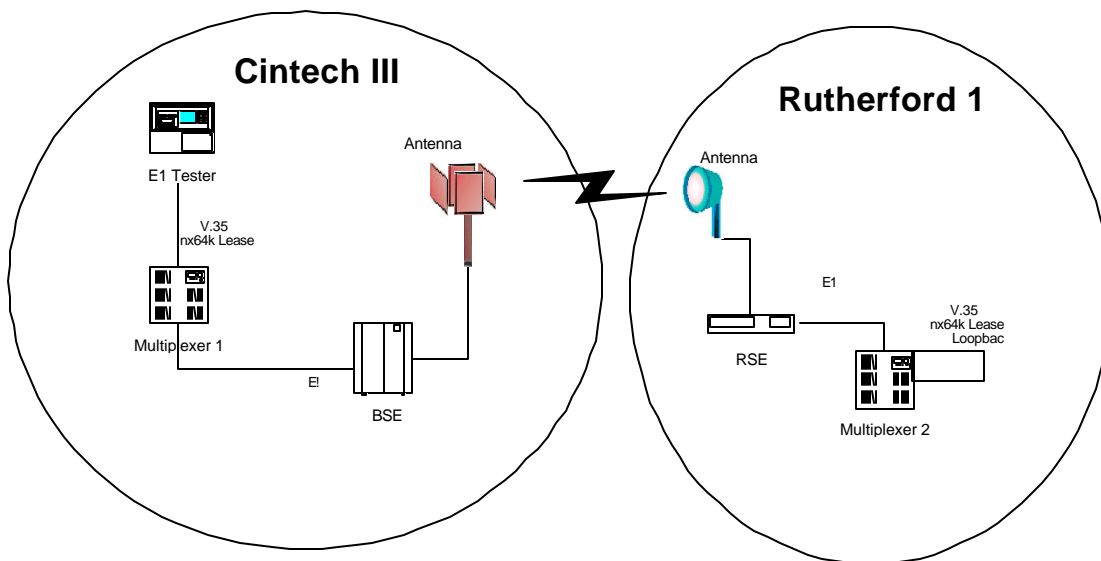

FIGURE 12.4

12.4.3. Test result

The test was completed successfully as per above configuration.

Test period	BER	Availability
15 minutes	0	100%

The zero BER verified the capability of the LMDS systems to carry fractional E1 traffic over the wireless ATM medium.

12.5 Voice Test

12.5.1. Objective

To verify that Plain Old Telephone Services (POTS) services could be carried over the LMDS.

12.5.2. Test Procedure

- Figure 12.5 illustrated the network diagram for this test.
- A 64k voice circuit was created at the BSE.
- Two multiplexers would be connected at the two ends of the LMDS.
- One multiplexer had a voice card with FXO interface. This interface would be used to terminate the voice circuit at the PSTN.
- The second multiplexer was connected to the E1 port of the RSE at Rutherford. A voice card with FXS interface was installed in this multiplexer. Hence, a normal telephone could be connected directly to the multiplexer via the FXS interface.
- A phone call was made from the telephone to a telephone number in PI office and a Singtel's handphone number.

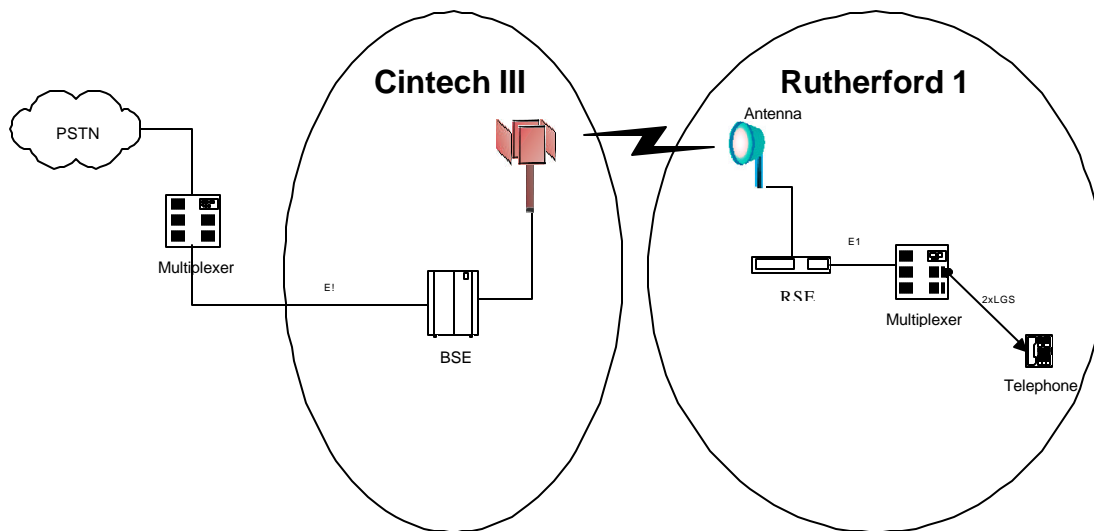

FIGURE 12.5

12.5.3. Test result

The voice circuit was commissioned successfully. Calls were made to a handphone number and a fixed line number respectively. However, echo was observed on the voice circuit. Investigation showed that the echo might be due to impedance difference.

13 Summary

The two LMDS trials conducted by Pacific Internet were considered successful.

The Bit Error Rate (BER) Test conducted demonstrated the effect of RainFall and distance to the Quality of Service. The Science Park Drive showed a zero BER even in heavy rain condition because of the short distance between the base station and remote station. On the other hand, as the distance between the two sites increased, the BER would increase, especially in heavy rain condition,

The Ethernet Throughput Test verified that the system was able to support broadband services with excellent throughput value.

A variety of application tests ran over the LMDS proved that the technology was able to support multiple narrowband and broadband applications successfully.

Some of the issues encountered during the trials included the difficulty in getting the rooftop access, congestion in the MDF room and the telecom risers, etc. These are the critical issues that have to be addressed in detail during the commercial deployment period.

In a nutshell, LMDS is a viable technology for the Singapore environment. Any new infrastructure player is able to rollout its own infrastructure rapidly to provide end-to-end services to its customers without relying on the incumbent.